



POWER TILT ASSEMBLY INSTRUCTION SHEET



Please read these instructions carefully before beginning the assembly. Failure to understand and follow assembly instructions may result in injury to technician and/or end user and may void the warranty. If you have any questions call Sunrise Medical Technical Support at +1 (800) 333-4000.

Parts list:

- | | |
|---|--|
| 1. Gear Teeth with Mounting Bracket (x1) | 7. Charger (x1) |
| 2. Control Box & Battery Box on Mounting Plate (x1) | 8. Strut Adapter (x2) |
| 3. Motor Unit & Attaching Brackets (x1) | 9. Shortened Oval Strut (x1) |
| 4. Battery Box/Control Box Cable (x1) | 10. Hardware Kit (at right) |
| 5. User Control with Mount and Hardware (x1) | if applicable |
| 6. Attendant Control (x1) | (retrofitting to chair without center thru holes): |
| | 11. Round Rocker Struts (x3) |
| | 12. Oval Strut (x1) |

POWER TILT HARDWARE KIT

POWER TILT HARDWARE KIT		
	BHCS,M6X1X16,FULL,PL	3
	HHCS M6X1X35 PART PL	2
	HHCS M6X1X30 PART NP ROHS	3
	NUT HEX NYLOCK M6X1.0	8
	SPACER 1/2 X 1/4 ID X 3/16 THK	2
	3/4" SADDLE THIN	1
	3/4" SADDLE 1" OD	2
	SHCS 5/16-24 X 1	2
	HHCS 5/16-24 2 1/4	2

SECTION 1: ATTACHING THE POWER TILT:**Chairs with Backrest Dual Trigger Cable Releases or Foot Release:**

If retrofitting onto a chair that has either the backrest dual trigger cable releases or the foot release, first remove these options.

Chairs without Center Thru Holes on Oval and Round Struts:

If chair does not have center thru holes (C) (Fig 1) on oval and round struts, remove all struts and discard struts. Take care to keep hardware to use with new struts. Replace with appropriate struts with center thru holes.

A: Preparing Struts for Retrofit:

1. a. IRIS HD:
 - i. Remove the rear oval strut (A) and existing bolt and discard. (Fig. 1)
 - ii. Remove nut (B). (Fig 1) Keep nut to use in step A:2.
- b. Standard IRIS:
 - i. Standard IRIS does not include rear oval strut (A). (Fig 1)
 - ii. Remove nut (B). (Fig 1) Keep nut to use in step A:2.
- c. SR45:
 - i. SR45 does not include oval struts on the chair. (Fig 2)
 - ii. Remove the hardware (D) (Fig 2 & Fig 3) and replace with longer oval strut.
 - iii. Next, remove the two nuts (E) (Fig 2).
2. a. Attach the strut adapter shown in Fig 4 with hole 3 toward the rear of the chair. (Fig 4 & Fig 5)
- b. Assemble again hardware (B) (Fig 1) through hole 1 using HHCS 5/16 24 x 2 1/4 (Fig 4). Hole 2 will align with the same hole used in the front oval strut and will use HHCS 5/16 24 x 2 1/4.
3. Use SHCS 5/16-24 X 1 to attach the shortened oval strut through hole 3 (Fig 4 & Fig 5).

Required tools:

1. 4mm Hex Key
2. 5mm Hex Key
3. 8mm Wrench
4. 10mm Wrench
5. 3/32-in Allen Wrench
6. 1/2-in Allen Wrench

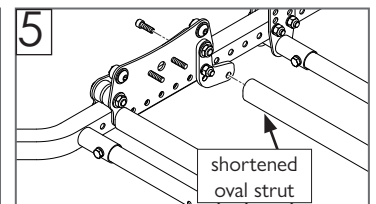
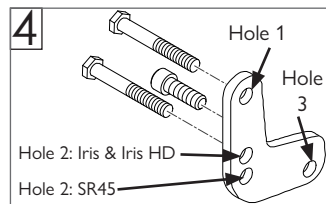
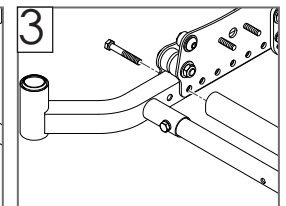
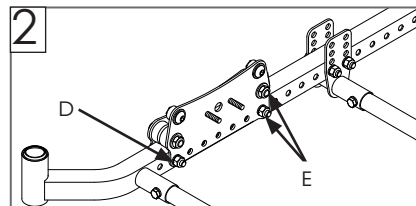
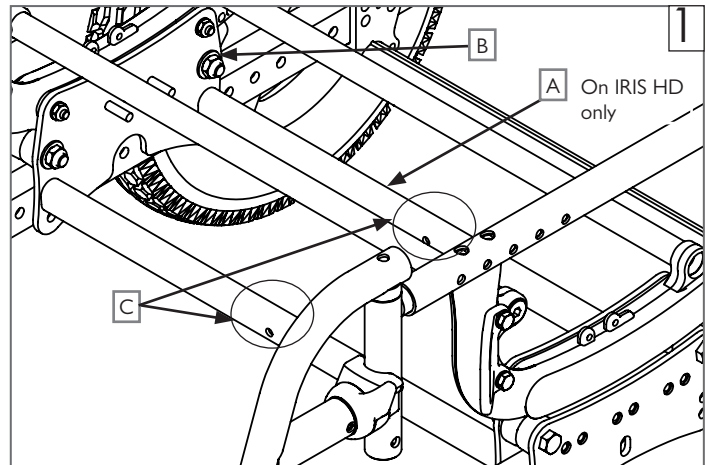
**⚠️ DEALER/TECHNICIAN WARNING**

Attention dealers and qualified technicians, do not operate or service this device without first reading the owners manual. If you do not understand the instructions and warnings in the owners manual please contact the Quickie Technical Service Department before operating and/or servicing the Quickie device. Failure to do so may result in damage and/or injury.

Find more information and important warnings see the wheelchair owner's manual or at: www.Sunrisemedical.com.

Sunrise Medical 2842 N. Business Park Ave Fresno, CA 93727 USA

Customer service: +1(800) 333-4000

or visit www.SunriseMedical.com

© 2020 Sunrise Medical (US) LLC

11/2020 253320 Rev.B Page 1 of 3



B: Attaching the Power Tilt:

1. The motor must be disengaged first. Move the motor disconnect pin from position A to position B (Fig 8). Keep the pin in this position until assembly is complete.
2. First, slide the gear teeth into the drive rack assembly. Then, slide the end of the gear teeth without the strut mount into the drive motor (Fig 6 and Fig 7).
3. Mount the gear rack and motor assembly onto the chair using the rear rocker strut and the lower oval struts (Fig 7).
 - a. The square attaching brackets will slide over the oval struts on the base, using:
 - Fixed struts: M6x35 screw, nut, and spacer.
 - Adjustable struts: M6x35 screw and nut.
 - b. Gear rack will attach to the rear round strut on the seat.
4. To attach the gear teeth to the rear rocker strut (step 2, Fig 7), remove the button head cap screw to open the strut mount. The gear teeth should cradle the rear and middle rocker strut. Then, attach again the button head cap screw to mount the gear teeth to the rear round strut.

Note: Make sure the motor pin is disengaged as some manual adjustment is needed in this step.
5. Mount the pre-assembled mounting plate with the control box and battery box onto the front and middle round strut using the center thru holes. A large saddle, M6x30, and nut will be used on both the front and middle round struts.

Note: It will be necessary to disconnect the cable between the battery and control box to easily reach the middle strut attachment point. Once the mounting plate is attached, ensure the cable between the battery and control box is properly connected. The cord connections will face the rear of the chair as shown (Fig 9).

Note: the mounting plate will attach on the BOTTOM side of the front round strut using a large saddle, M6x30, and nut (step 3, Fig 9). The mounting plate will then connect with two M5x10 bolts to the gear rack as shown (step 4, Fig 9).

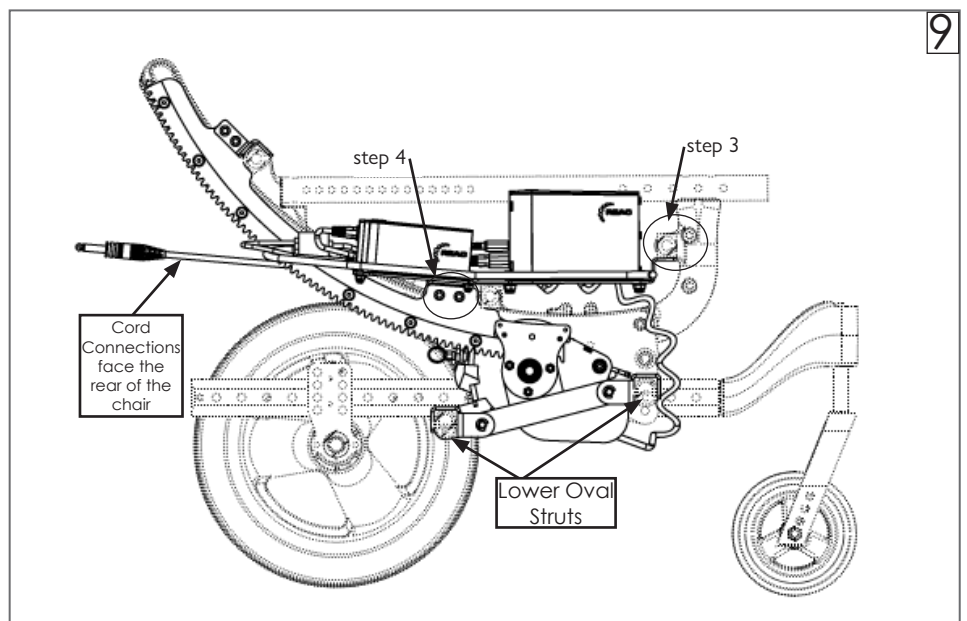
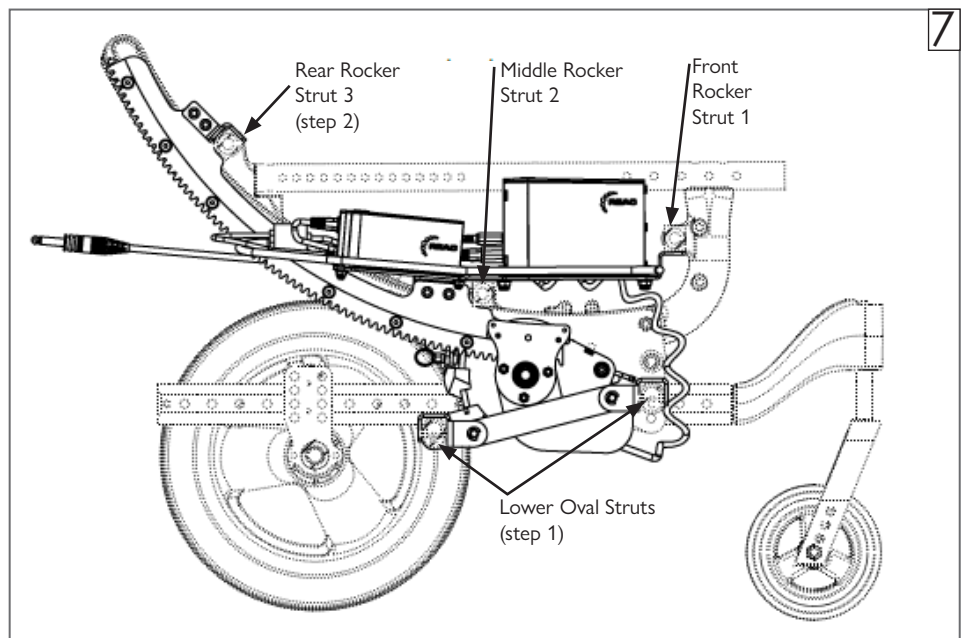
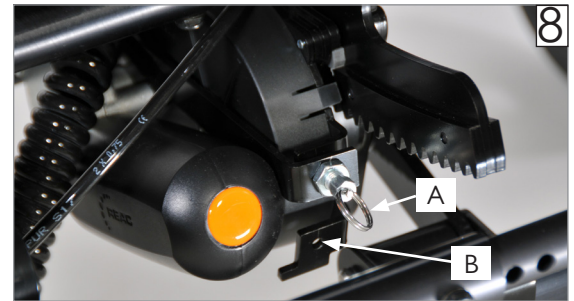
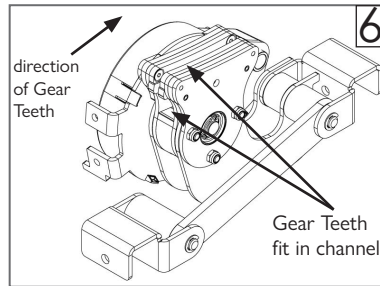

B: Attaching the Power Tilt (continued):

6. Connect the cables for the attendant control and the user control (Fig 10 and Fig 11):
 - The cable from the drive rack assembly will connect into the larger (top) orange port on the control box.
 - The attendant control will connect into the HC port.
 - The user control will connect directly into the battery box and the smaller (bottom) orange port on the control box.
7. Engage the motor assembly pin by moving it back to position A. (Fig 8)

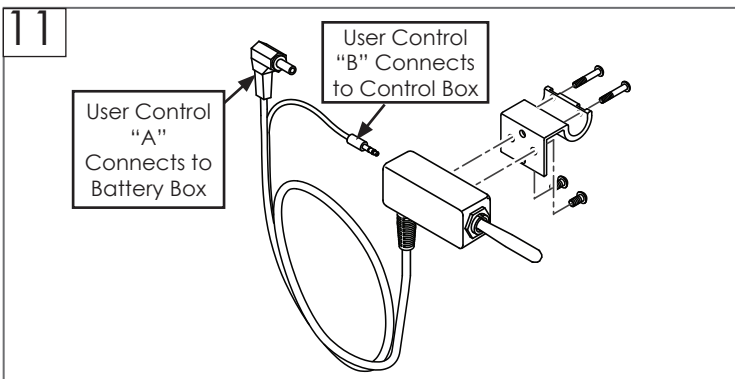
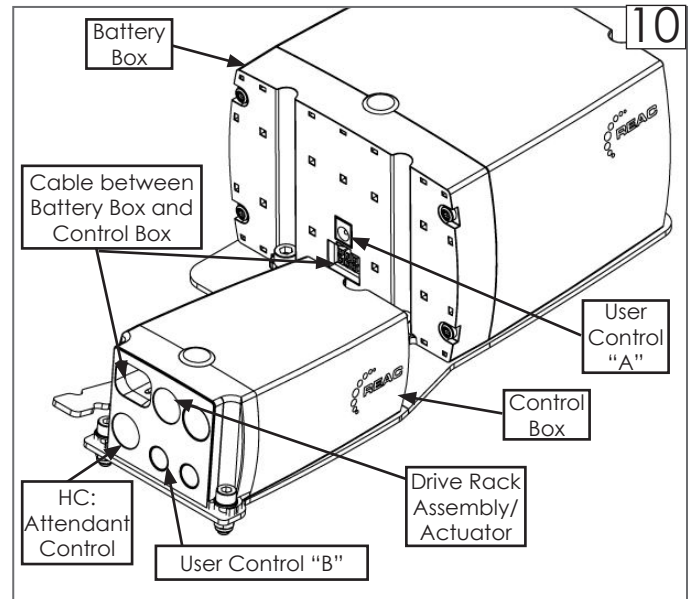

SECTION 2: POWERING ON AND OFF THE DEVICE

1. Checking battery level: battery level is indicated on the attendant control.
2. The attendant control will power off/on the unit.
3. The user control switch will not activate the tilt if the unit is powered off.
4. Charging port is located on the bottom of the user control.