

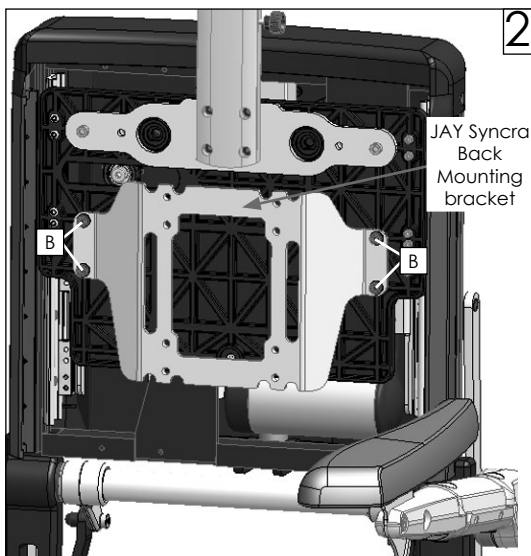

SEDEO® PRO ADVANCED JAY® SYNCRA® BACK MOUNT

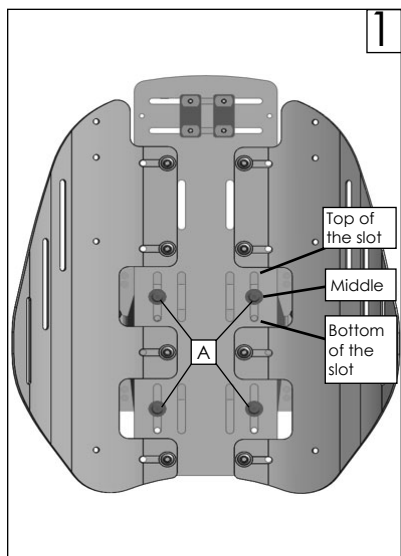

Please read these instructions carefully before beginning the assembly. Failure to understand and follow assembly instructions may result in injury to technician and/or end user and may void the warranty. If you have any questions call Sunrise Medical Technical Support at +1 (800) 333-4000.



Required tools:

1. 5mm hex key
2. Torque wrench

Backrest height adjustment instructions

Note: All bolts use 5mm tool and torque to 6.8-7.9 Nm [60-70 in-lbs].

Adjustment option 1

1. Loosen 4 center bolts holding back shell to back shell mount (A x4). (Fig. 1)
2. Slide back shell up or down within slot.
3. Retighten bolts when back shell reaches desired height.

Adjustment option 2

1. Remove 4 center bolts fixing the back shell to back shell mounting bracket (A x4). (Fig. 1)
Note mounting hole 1 or 2. (Fig. 3)
2. If mounting bolts were in mounting hole 2, increase back height by mounting bolts in hole 1.
3. If mounting bolts were in mounting hole 1, decrease back height by mounting bolts in hole 2.

Adjustment option 3

1. The back height can be further adjusted by rotating the JAY 3 mounting bracket. (Fig. 2)
2. Remove back shell by removing the 4 center bolts (A x4). Save bolts for reattachment. (Fig. 1)
3. Note the orientation of the back mounting bracket. (Fig. 3)
 - a. If the orientation is "HIGH", then rotating the mounting bracket will decrease back height.
 - b. If the orientation is "LOW", then rotating the mounting bracket will increase back height.
4. Remove 4 bolts that attach backrest mounting bracket (B x4). Save for reattachment. (Fig. 2)
5. Rotate bracket 180°. (Fig. 3)
6. Attach again hardware removed in step 4.
7. Attach center bolts removed in step 2 and retighten at desired height.

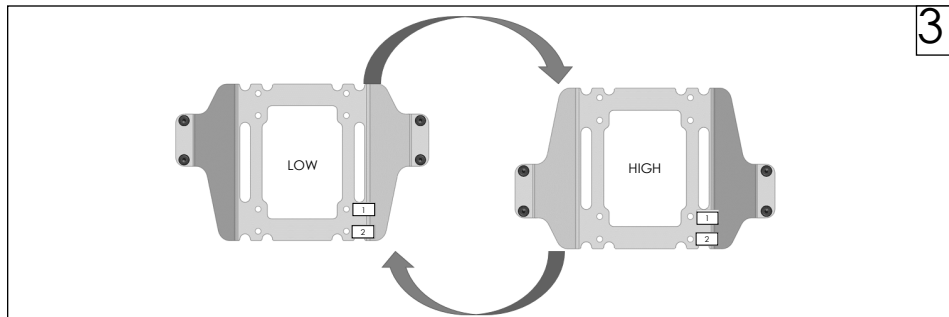

Recommended Adjustment Ranges

Installed Back Height	Syncra Shell Height	Installed Back Height	Syncra Shell Height
22-in	16-in	26-in	20-in
23-in	16-in	27-in	20-in
24-in	16-in	28-in	20-in
24-in	18-in	28-in	22-in
25-in	18-in	29-in	22-in
26-in	18-in	30-in	22-in

⚠️ DEALER/TECHNICIAN WARNING

Attention dealers and qualified technicians, do not operate or service this device without first reading the owners manual. If you do not understand the instructions and warnings in the owners manual please contact the Quickie Technical Service Department before operating and/or servicing the Quickie device. Failure to do so may result in damage and/or injury.

Find more information and important warnings in the wheelchair owner's manual or at: www.SunriseMedical.com.

Sunrise Medical 2842 N. Business Park Ave Fresno, CA 93727 USA In Canada: (800) 263-3390



**Customer Service: +1(800) 333-4000
or visit www.SunriseMedical.com**

© 2022 Sunrise Medical (US) LLC
03/2022 255939 Rev. A