

Rogue2 Footrest - Tubular Open

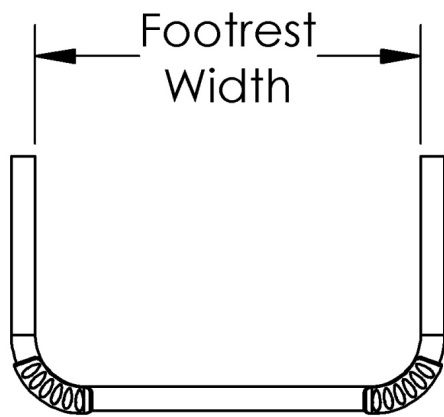
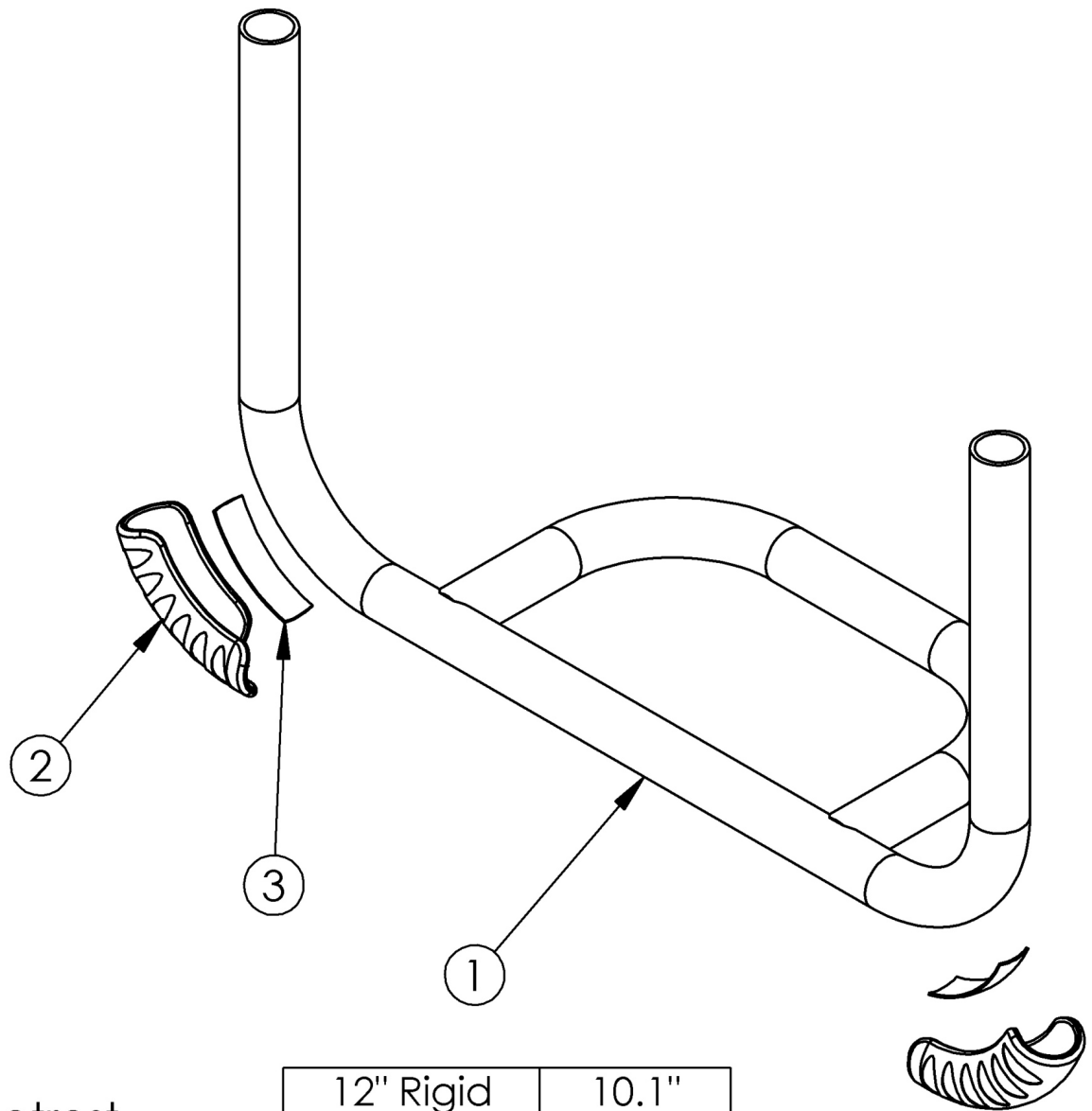

12" Rigid	10.1"
13" Rigid	11.1"
14" Rigid	12.1"
15" Rigid	13.1"
16" Rigid	14.1"
17" Rigid	15.1"
18" Rigid	16.1"
19" Rigid	17.1"
20" Rigid	18.1"

Not available with V-Taper options. Sizes based on straight frame. If changing from a high mount footrest to a frame inserted footrest, please see the "Rogue2 Rigid Frame" page for necessary attaching hardware.

Item Number	Part Number	Description	Quantity
2, 3	501739	Footrest Protector w/ Instructions Kit Left Rigid	1
2, 3	501740	Footrest Protector w/ Instructions Kit Right Rigid	1
2, 3	501741	Footrest Protector w/ Instructions Kit PAIR Rigid	1
1a	000214	Footrest Tubular 12" Rigid	1
1b	000215	Footrest Tubular 13" Rigid	1
1c	000216	Footrest Tubular 14" Rigid	1
1d	000217	Footrest Tubular 15" Rigid	1
1e	000218	Footrest Tubular 16" Rigid	1
1f	000219	Footrest Tubular 17" Rigid	1
1g	000220	Footrest Tubular 18" Rigid	1
1h	000905	Footrest Tubular 19" Rigid	1
1i	000906	Footrest Tubular 20" Rigid	1

Distance between Point A and Point B = Footplate Length

NOTE: The yardstick on the top plane of the seat frame must lie flat against frame. The yardstick going from the footplate to the second yardstick must be square against the hanger tube.

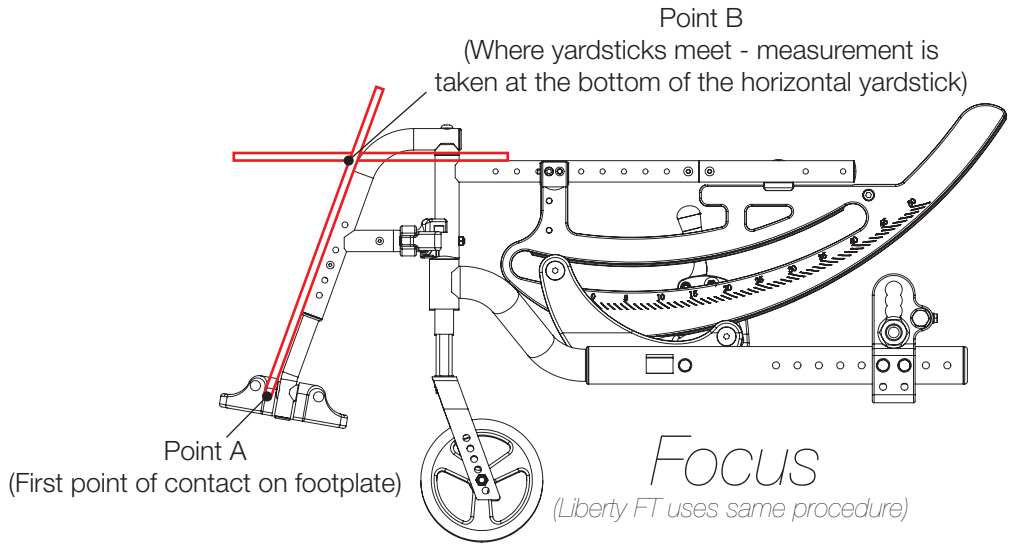

Distance between Point A and Point B = Footplate Length

NOTE: The yardstick on the top plane of the seat frame must lie flat against frame. The yardstick going from the footplate to the second yardstick must be square against the front tube.

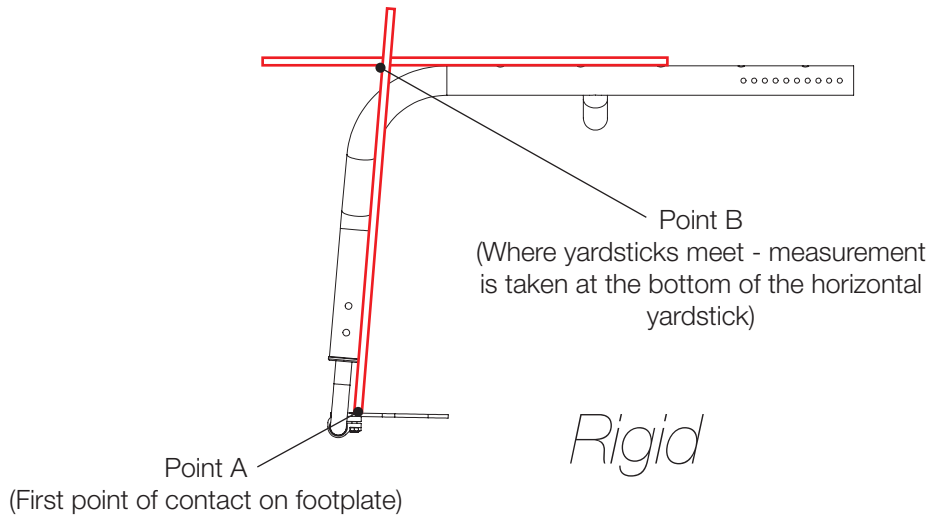

Distance between Point A and Point B = Footplate Length

NOTE: The yardstick on the top plane of the hanger must lie flat against hanger. The yardstick going from the footplate to the second yardstick must be square against the hanger tube.

