



## SEDEO PRO SEMI-RECLINE POWER BACK SEAT ASSEMBLY INSTRUCTION SHEET



Please read these instructions carefully before beginning the assembly. Failure to understand and follow assembly instructions may result in injury to technician and/or end user and may void the warranty. If you have any questions call Sunrise Medical Technical Support at (800) 333-4000.

If your seat is received with Armrest: See Section 1

If your seat is received without Armrests: See Section 2

### SECTION 1: WITH ARMRESTS



#### Required tools:

1. 3mm hex key
2. Phillips screwdriver
3. 13mm crescent wrench
4. Torque wrench

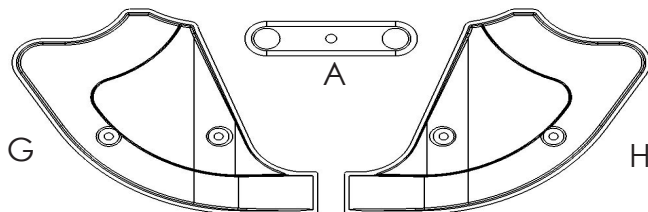

#### Sedeo Pro Semi Recline Gas Spring with Armrest Assembly Parts (Section 1):

- |                                      |                                 |
|--------------------------------------|---------------------------------|
| 1. 2 ea armrest link (A)             | 5. 2 ea Washer (E)              |
| 2. 4 ea retaining clip (B)           | 6. 4 ea Phillips Head Screw (F) |
| 3. 2 ea M4x10 SHCS Screw (C)         | 7. 1 ea Left Corner Shroud (G)  |
| 4. 2 ea Internally Threaded Bolt (D) | 8. 1 ea Right Corner Shroud (H) |

#### A. With armrest: installing armrest link

1. Unfold the backrest, and raise the armrest in order to install the armrest link (A) with the bushing facing toward the pins as shown in figure 1.
2. Install the retaining clips (B) onto the pins as shown in Figure 2 and 3.
3. Repeat steps 1 and 2 to the opposite side of the chair.

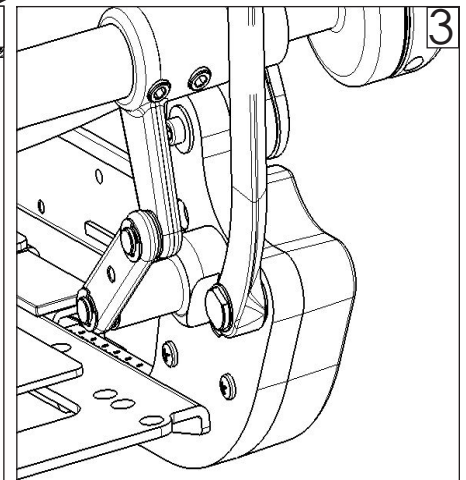
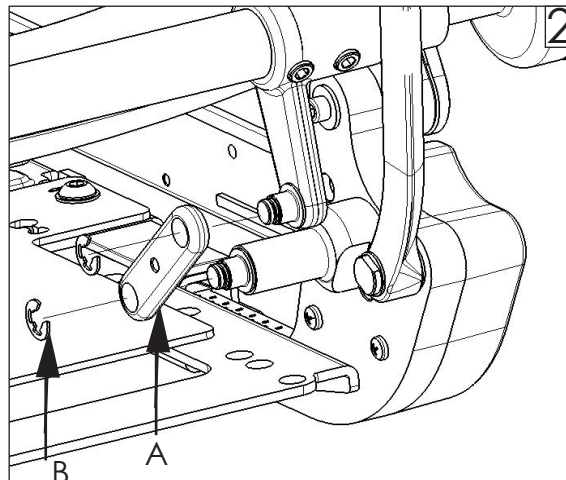
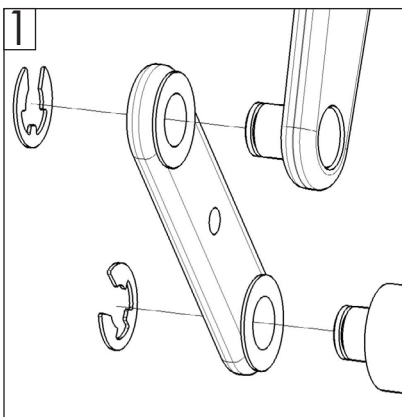
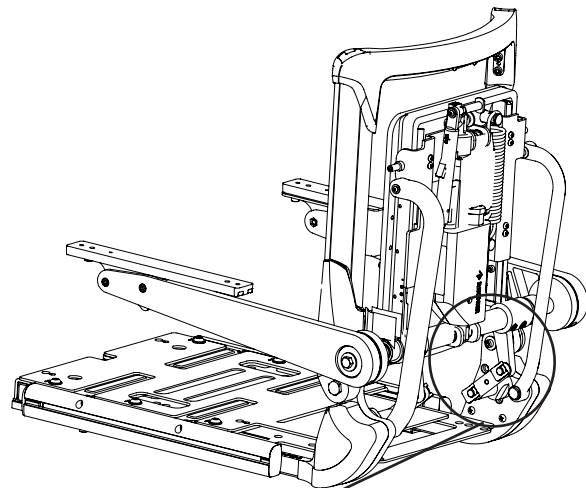

Sunrise Medical 2842 N. Business Park Ave Fresno, CA 93727 USA  
In Canada (800) 263-3390



Customer service: (800) 333-4000  
or visit [www.SunriseMedical.com](http://www.SunriseMedical.com)

© 2020 Sunrise Medical (US) LLC  
09/2020 251265 Rev. A Page 1 of 2





## SEDEO PRO SEMI-RELCINE POWER BACK SEAT ASSEMBLY INSTRUCTION SHEET

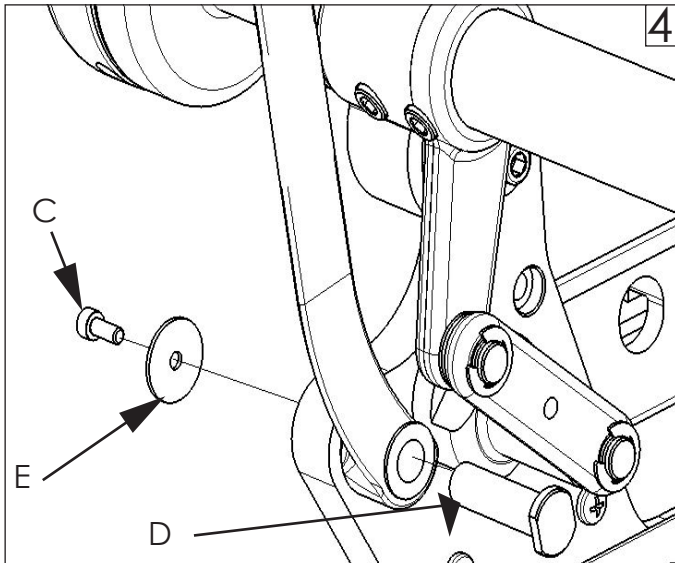

Please read these instructions carefully before beginning the assembly. Failure to understand and follow assembly instructions may result in injury to technician and/or end user and may void the warranty. If you have any questions call Sunrise Medical Technical Support at (800) 333-4000.



### B. With Armrest: Installing Backrest Link

1. Insert Internally Threaded Bolt (D) through the Backrest Link and the seat, as shown in Figure 4.
2. Using a 3mm hex key, install M4 screw (C) through washer (E) and thread into Internally Threaded Bolt (D), as shown in Figure 4. Using the torque wrench, torque the M4 SHCS to 2.0 ft-lbs (2.7Nm) 
3. Repeat steps 1 and 2 to the opposite side of the chair.
4. Insert Phillips Head screws (F) through the chair as shown in Figure 5. Thread into Left Corner Shroud (G). Using a torque wrench, torque the Phillips Head screws to 2.2 ft-lbs (3.0Nm). 
5. Repeat Step 4 to the opposite side of the chair using Right Corner Shroud (H).

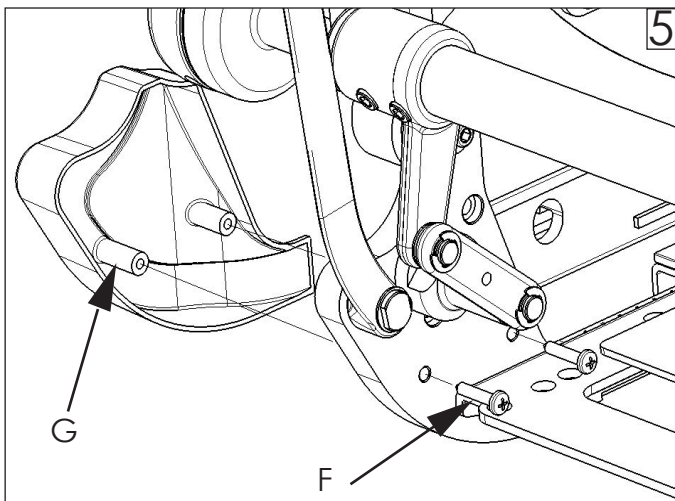

### C. Inspect

1. Inspect to verify all torque specifications are met. 
2. Verify the armrest recline up and then back down again.

## SECTION 2: WITHOUT ARMRESTS

Perform the install outlined in Section B using the Hardware C-H.

### D. Inspect

1. Inspect to verify all torque specifications are met. 

### DEALER/TECHNICIAN WARNING

Attention dealers and qualified technicians, do not operate or service this device without first reading the owners manual. If you do not understand the instructions and warnings in the owners manual please contact the Quickie Technical Service Department before operating and/or servicing the Quickie device. Failure to do so may result in damage and/or injury.

Find more information and important warnings see the wheelchair owner's manual or at: [www.Sunrisemedical.com](http://www.Sunrisemedical.com).

Sunrise Medical 2842 N. Business Park Ave Fresno, CA 93727 USA  
In Canada (800) 263-3390



Customer service: (800) 333-4000  
or visit [www.SunriseMedical.com](http://www.SunriseMedical.com)

© 2020 Sunrise Medical (US) LLC  
09/2020 251265 Rev. A Page 2of2