

# Dynamic Stander (16")

K110 Product Manual



CE

 rifton®

# Contents

Warnings and Important Information	3
Recommended Use	4
Assembly	4
User and Item Dimensions	4
Adjustments	5
Operation	6
Sandals & Wedges	7
Arm Prompt Set	8
Communication Tray	9
Maintenance	10
Cleaning	10
Construction	11
User Modifications	11

## Key for EU users

Use this key to determine which sections of this Product Manual apply to your job.

 **Technical Users** For professionals who order and set up Rifton products.

 **Home Users** For clients and care-givers who use Rifton products on a regular basis.

 **Maintenance Personnel** For anyone who is responsible for service or re-ordering of Rifton products and parts.

## **WARNINGS**

- Correct use of this product requires the prior approval and ongoing guidance of a qualified therapist or physician.
- Adult supervision is required at all times.
- Straps and supports are provided for the safety of the user. The use of straps and supports must be closely supervised. The straps and supports need to be carefully adjusted for the comfort and security of the user. Straps and supports can never take the place of the caregiver.
- Use only on a level, unobstructed surface indoors and outside. Do not use near steps, sloped driveways, roads, alleys, or swimming pools.
- Before placing a child in the stander, be sure you have read and understood the adjustment instructions.

## **IMPORTANT**

- Please save this Product Manual. Additional copies are available at [www.rifton.com](http://www.rifton.com)
- Please refer to the Rifton product catalog for our full warranty, or visit [www.rifton.com](http://www.rifton.com)

## **To order replacement parts**

1. Locate the serial number of the product on the small white label.
2. Have this number available when you call **800.571.8198** for your customer service representative.

**Use only replacement parts supplied by Rifton Equipment.**

## Recommended Use

The Dynamic Stander is a device to help a child to stand. The straps, seat pad, and contoured body support allow full to no weight bearing. It is possible to stand a child in the Dynamic Stander even without active use of trunk and leg muscles.

The wide standing platform helps the user to spread his or her legs for hip development, or to accommodate leg braces. The platform is free of obstruction to facilitate placing the child in the stander.

Five-inch, lockable casters in the rear of the Dynamic Stander enable its use outdoors on hard, level terrain.

**MOVE Curriculum:** Available from MOVE International, this comprehensive text explains the MOVE program and describes the use of the specially designed MOVE equipment.

## Assembly

Your Dynamic Stander comes fully assembled.

**If your shipment is incomplete, please call Customer Service.**

## User and Item Dimensions

User Dimensions – Inches (cm)	K110	K130	K150	K170
Height	25-32 (64-81)	30-40 (76-102)	37-52 (94-132)	48-65 (122-165)



### Key User Dimension: Height

Select the appropriate Dynamic Stander by the user's overall height. Choose the model that allows for growth.

**Important:** User's weight must not exceed the maximum working load.

Item Dimensions – Inches (cm)	K110	K130	K150	K170
Overall length and width	25 x 25½ (64 x 65)	25 x 25½ (64 x 65)	32 x 29 (81 x 74)	39 x 33½ (99 x 85)
Overall height	22½-28 (57-71)	23½-30 (60-76)	30-39 (76-99)	37½-49 (95-124)
Width without big wheels	21 (53)	21 (53)	25 (64)	28½ (72)
Wheel diameter	20 (51)	20 (51)	27 (69)	35 (89)
Width of body support	7-10 (18-25)	7-10 (18-25)	9-12 (23-30)	10-14 (25-36)
Height of body support	16½-22 (42-56)	22-29 (56-74)	29-38 (74-97)	36-48 (91-122)
Item weight – lbs (kg)	28 (13)	30 (14)	40 (18)	65 (29)
Max. working load – lbs (kg)	50 (23)	50 (23)	120 (54)	175 (79)

## Adjustments

See Figure 1 and 2.

1. Use knobs (A) to adjust body support up and down. Always adjust body support height and tighten both knobs (A) before the child is in the stander.
2. Use 4 knobs (B) to adjust width of body support.
3. Top strap (C) can be adjusted and positioned in the center of the back, underneath the arms, or crossed in front of the body support. It can also come behind the head to be used as a neck support.
4. The seat pad (D) can be adjusted up and down and angled in a variety of ways. Four separate straps (E) and multiple snap hook positions (F) allow for individual positioning needs. By adjusting the position and angle of the seat pad, the child can be snugly supported in an upright standing position or in a flexed stance to allow for contractures of the hips and knees.
5. Knee straps (G) are used to secure the knees in a standing or partially standing position. Ankle straps (H) keep feet apart. If a child needs extra support, an additional seat pad can be ordered. For better foot positioning, sandals and wedges can be ordered as an accessory.
6. Optional 16" wheels can be removed with a simple push button. Rolling on casters, the Dynamic Stander then allows for more convenient interaction between the child and his or her environment.

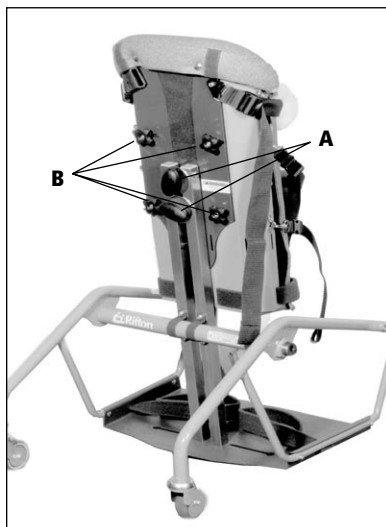

Figure 1

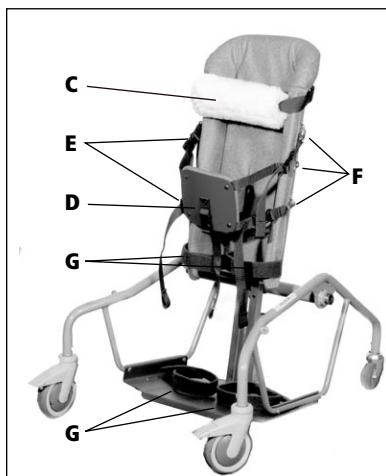

Figure 2

## Operation

To safely place a child in the Dynamic Stander, immobilize the unit by applying the wheel locks.

Release snap hooks or buckles on one side of seat pad and center strap of seat pad, allowing seat pad to swing out of the way.

Release one side of top strap and swing it out of the way.

Carefully place the child into the stander from the back.

The seat pad should be placed under the child's buttocks. If the child is non-weight-bearing, position it at an angle appropriate to bear the child's weight. If the child is weight-bearing, the pad should be positioned vertically.

The top strap should be placed under the child's arms, with fleece in back, and fastened behind the child's back.

After placing the child in the unit, review the following checklist:

- Is the bottom of the body support below the knees?
- Is the top of the body support about nipple level or lower?
- Are the feet placed under the hips and as far forward on the platform as possible without causing discomfort?
- Is the body properly aligned?
- Is the body support adjusted to the proper width?
- Are all the straps fastened and snug?
- Is the child free of discomfort?

When removing the child from the stander, insure that the child is sufficiently supported as straps are released. Begin by releasing restraints from the feet to the knees and work upwards.

# Small Pair of Sandals & Wedges (K114)

## Recommended Use

The K114 Pair of Sandals With Wedges is designed for use with the K110 Dynamic Stander, 16". The sandals, straps, and wedges position and hold feet firmly on a wide platform to encourage standing.

## Assembly

1. Loosen both knobs (D) on the sandal for the right foot this sandal will have heel strap to the rear and adjustment knobs on the instep when you are done, as shown in diagram (C).
2. Position sandal on platform as shown in diagram (A) and insert first bolt head into key slot.
3. Rotate sandal to position shown in diagram (B) and insert other bolt head into key slot.
4. Rotate and/or slide sandal to desired position. Pull upwards on knobs while turning to tighten.
5. Repeat steps 1–3 for left foot sandal.

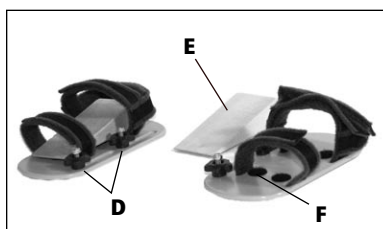

Figure 3. Pair of Sandals with Wedges

## Adjustments

1. Use knobs (D) to adjust sandal forward and back, side to side, and to desired foot angle on platform. Dual knob adjustment provides extremely versatile foot positioning.
2. Wedges (E) can be used to elevate the toe or heel according to the child's needs. Velcro on the bottom of the wooden wedge adheres to velcro dots on sandal (F). If one of the child's legs is shorter than the other, two wedges can be combined and placed underneath the foot to raise it. Extra velcro dots provided should be placed on face (E) to combine two wedges.

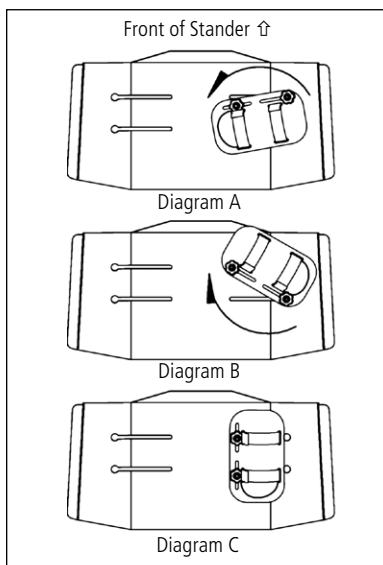

Figure 4

### **WARNINGS**

- This accessory is intended for use on the K110 16" Dynamic Stander only.

# Arm Prompt Set (K132) with Small Mounting Bracket (K133)

## Recommended Use

The Mounting Brackets, Tray and Arm Prompts are designed for use with Dynamic Stenders only. The **Arm Prompt Set** is designed to give additional support for a child with poor head and/or shoulder control. It stimulates the child to raise his/her head. The K133 **Small Mounting Bracket** is needed to use the K132 Arm Prompt Set and/or the K188 Communication Tray on the Rifton K110 and K130 Dynamic Stenders.

## Installation

K133 Mounting Bracket (see Figure 5): Loosen the top two knobs (A) on the body support of the Dynamic Stender. Slide the slotted Mounting Bracket (B) under the knobs. Tighten the knobs securely. The Arm Prompts and/or the Communication Tray can now be attached.



Figure 5

Installation K132 Arm Prompt Set (see Figure 6) Loosen the clamp knob (C) and pull it down to free the curved metal piece. Slip the clamp over the oval tube of the Mounting Bracket with the main part of the clamp to the inside of the Mounting Bracket. Close the curved metal piece, pull the knob up and tighten it securely.

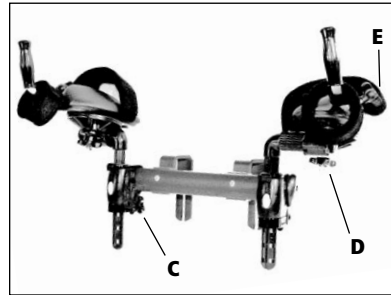

Figure 6

## Adjustments

### To adjust the Arm Prompts:

Use knob (D) to adjust the Arm Prompt sideways, forward or backwards, for elbow rotation, and to angle up or down.

Use Knob (E) to rotate the handhold and to adjust it in and out.

To position the Arm Prompt further forward than the factory setting, press the clamp button and slide the prompt out. Next, loosen the knob (C) and remove the clamp from the Mounting Bracket. Turn the clamp around and remount it with its knob to the inside. Slide the Arm Prompt back into the clamp.

**NOTE:** To benefit from the full range of adjustment of the Arm Prompts, it is recommended to remove the large wheels while the prompts are in use.



# Communication Tray (K188) with Small Mounting Bracket (K133)

## Recommended Use

The Communication Tray provides a surface for personal communication devices and for other activities. Communication Sheets can be placed under the false bottom and electronic devices can be secured to the tray. The tray can be easily removed when not in use.

## Installation

K188 Communication Tray (see Figure 7)  
The same Mounting Bracket that is used for the Arm Prompts can also accommodate a K188 for manipulative activities and communication devices.

Loosen the clamp knob (C) and pull it down to free the curved metal piece. Slip the clamp over the oval tube of the Mounting Bracket with the main part of the clamp outside of the bracket. Close the curved metal piece, pull the knob up and tighten it securely.

## Adjustments

To adjust the tray (see Figures 8)

1. The Knob (A) allows rotational adjustment of the tray. Loosen the knob (A) to change the tilt angle of the tray or to rotate the tray from side to side.
2. To adjust the height of the tray, press the button (B), slide the post to desired position, and release the button (B).
3. Loosen knob (C) to completely remove the tray from the Dynamic Stander.
4. The Tray Insert can be removed by pressing fingers upward through the holes. Re-install the insert by placing the tabs in the slots at the bottom of the tray. Then press down on the front top edge of the insert until it snaps in place.

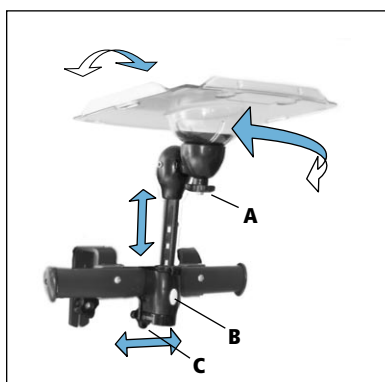

Figure 7

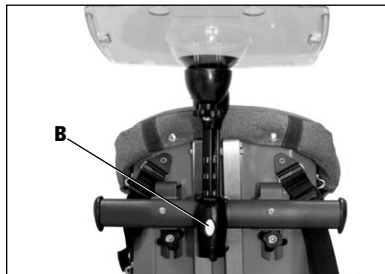

Figure 8

### **WARNING**

- This accessory is intended for use on this Rifton Product.

### **CAUTION**

- The tray is meant to support activities compatible with mobility. It is not designed to be used as a restraint or for body support.

## Maintenance 🛠️

Periodically inspect for cracks, breaks, loose parts, missing parts, and/or malfunctions.

Remove the product from service when any condition develops that might make operation unsafe.

Twice a year, perform the following maintenance:

- Apply a drop of oil to the caster bearings and wheel axle.
- Inspect all nuts. Tighten if necessary.
- Inspect strap stitching and replace if they become frayed.

## Cleaning 🧑🏠 🛠️

Clean metal parts with a damp cloth, water, and a mild detergent or mild disinfectant. Rinse well with a damp cloth and water. Vinyl pads can be cleaned the same way, or use a commercial cleaning agent suitable for imitation leather. Fleece sleeve is easily removable for laundering. Bib can be machine washed as necessary.

## Construction

The frame is constructed of welded steel tubing with a durable baked-on finish.

The safety straps and supports are made of nylon and polypropylene and the locking buckles are made of a tough polymer.

Upholstery is urethane foam covered with expanded vinyl.

Adjustments are made by means of plastic knobs with steel threads.

Hand Rims are constructed of anodized aluminum.

Tires on large wheels are tubeless and are made from latex-free urethane foam.

## User Modifications

We recognize that some clients may benefit from modifications made in the field. However, we cannot be responsible for customer-modifications to our products without our supervision, testing, or evaluation.

# Rifton Contact Info



## Online

[www.Rifton.com](http://www.Rifton.com)

[Sales@Rifton.com](mailto:Sales@Rifton.com)



## Phone

800.571.8198

9–5 EST



## Mail

Rifton Equipment

PO Box 260

Rifton NY 12471–0260



## Fax

800.865.4674