



IRIS TRANSIT KIT



Please read these instructions carefully before beginning the assembly. Failure to understand and follow assembly instructions may result in injury to technician and/or end user and may void the warranty. If you have any questions call Sunrise Medical Technical support at +1 (800) 333-4000

I. Parts included in this Transit Kit:

- | | |
|----------------------------------|------------------------------------|
| a. 2x Rear Transit Loops | e. 2x Bushings and Washers (Rear) |
| b. 2x Front Transit Bracket | f. 4x Washer & 2x Wave Washer |
| c. 2x 5/16" Button Head (Rear) | g. 2x 5/16" Nylock Nut (Rear) |
| d. 2x 1/4-20 Button Head (Front) | h. 2x 1/4-20 Nylock Nut (Front) |
| | i. 1x Transit Strut (Fixed or Adj) |

2. Tools needed:

- 1/4" hex key
- 3/16" hex key
- 1/2" open end wrench
- Torque Wrench with Standard hex bits.

A. REAR TRANSIT BRACKET ASSEMBLY

NOTE –The occupant must be removed from the IRIS for this assembly.

1. Remove the original Rear Strut 1

- Using a 3/16" or 1/4" Hex key, remove the screws (A) holding the rearmost strut tube (B) to the rocker frame (C).

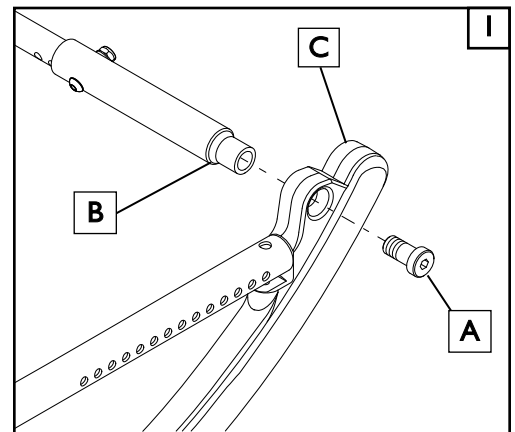

2. Place the new Transit Strut 1

- Position the Transit Strut included in your kit and proceed to Step 3

3 Assemble the Rear Transit Brackets for a standard dual-post back 2

- Using the 3/16" hex key, assemble the parts as shown and thread the 5/16" button head screw (D) through the hardware and into the strut tube (B).
- Make sure the Wave Washer is in the correct location (G)
 - !** **WARNING:** take care with the Wave Washer (G) as it must be centered. You may apply two drops of contact adhesive in order to keep wave washer centered during assembly. Wait until dry, then assemble the bracket.
- Repeat this process for the opposite side of the chair.
- Tighten both button head screws holding the transit brackets (E) to the frame. Torque to 80 in-lb.

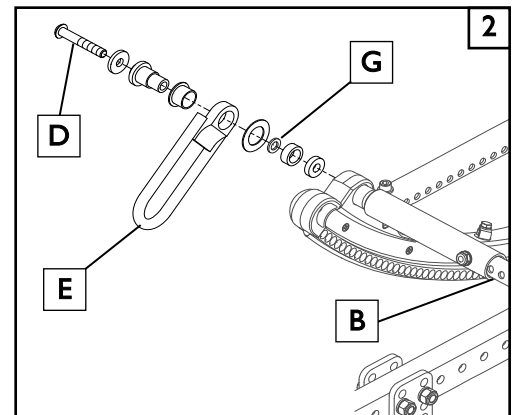

4. Assemble the Rear Transit Brackets for a single-post back 3 (OPTIONAL)

- Using the 3/16" hex key, assemble the parts as shown and thread the 5/16" button head screw through the hardware and and rocker (C) into the nylock nut (F).
- Make sure the Wave Washer is in the correct location (G)
 - !** **WARNING:** take care with the Wave Washer (G) as it must be centered. You may apply two drops of contact adhesive in order to keep waver washer centered during assembly. Wait until dry, then assemble the bracket.
- Repeat this process for the opposite side of the chair.
- Tighten the hardware using a 1/2" open wrench and 3/16" hex key. Torque to 80 in-lb.

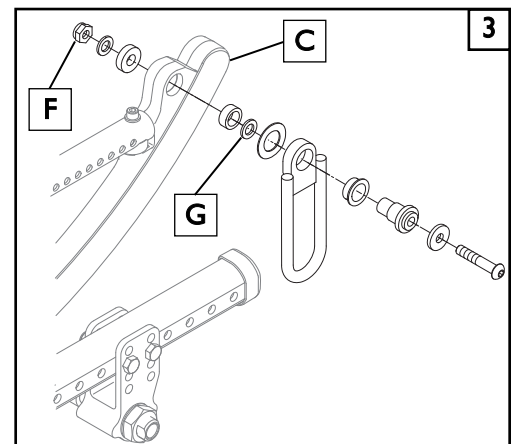

B. FRONT TRANSIT BRACKET ASSEMBLY

4

I. Assemble and Place the Front Transit Bracket

- a. Place the front transit bracket (A) on the frame location (B) and insert the hex head screws (C) through the washers into the rocker frame.
- b. Slide the washers (D) on the hex head screw and hand tighten the nylock nuts (E).
- c. Finish by tightening the hex-head screws (C) to a maximum torque of about 120 in-lb.
- d. Repeat this process for the other side of the wheelchair.

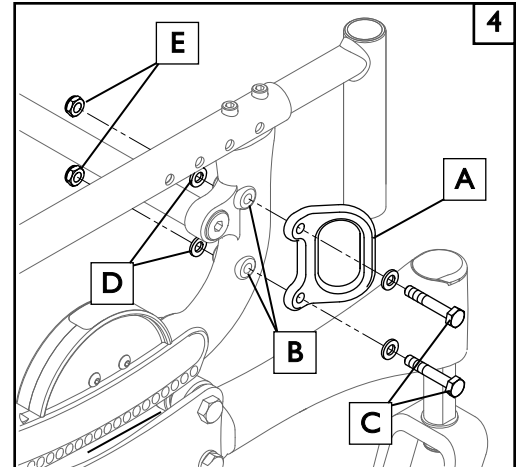

C. TRANSIT STICKERS

5 6

I. The placement of Transit hook location stickers is essential for the safety of the rider and compliance with WC-19 standards.

- a. Peel the backing from the Front Transit Hook decals and place them on each side of the chair in the location shown in Figure 5.
- b. Peel the backing from the Rear Transit Hook decals and place them on both sides of the chair in the location shown in Figure 6.
- c. Peel the backing from the WC-19 Transit decals and place them on both sides of the chair in the location shown in Figure 6.

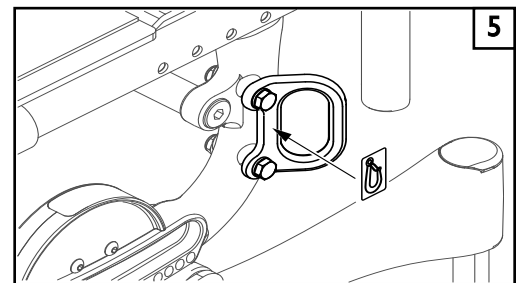

D. CHECKOUT

I. Double-check Orientation and Torque on all Hardware.

- a. Check that front and rear transit brackets have been installed evenly.
- b. Using a torque wrench, check front and rear screws for correct torque.

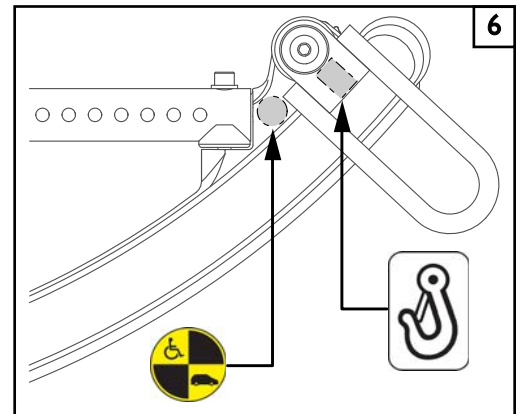

DEALER/TECHNICIAN WARNING



WARNING
Attention dealers and qualified technicians, do not operate or service this wheelchair without first reading the owners manual. If you do not understand the instructions and warnings in the owners manual please contact the Quickie Technical Service Department before operating and/or servicing the Quickie wheelchair. Failure to do so may result in damage and/or injury.

IMPORTANT– Please see the QZ IRIS owner’s manual, and the WC-19 Transit supplement included with this kit, for additional warnings and information.

Sunrise Medical • 2842 Business Park Ave. • Fresno, CA 93727 • USA
In Canada (800) 263-3390



Customer Service: +1 (800) 333-4000
www.SunriseMedical.com

©2020 Sunrise Medical (US) LLC
05.2020 IS00140 Rev.B