



TR

Series 1, 2 and 3

YR

Series 2

OWNERS MANUAL

DEALER/SUPPLIER:

THIS MANUAL MUST BE GIVEN TO THE USER OF THIS WHEELCHAIR.

USER:

BEFORE USING THIS WHEELCHAIR, YOU MUST READ THIS MANUAL IN ITS ENTIRETY AND SAVE IT FOR FUTURE REFERENCE.

ATTENDANTS/ASSISTANTS:

BEFORE ASSISTING THE USER OF THIS WHEELCHAIR, YOU MUST READ THIS MANUAL IN ITS ENTIRETY AND SAVE IT FOR FUTURE REFERENCE.

SERIAL NUMBER _____

⚠ WARNING - READ THIS MANUAL

DO NOT OPERATE THIS WHEELCHAIR WITHOUT FIRST READING AND UNDERSTANDING THIS OWNER'S MANUAL. IF YOU ARE UNABLE TO UNDERSTAND THE WARNINGS, CAUTIONS AND INSTRUCTIONS, CONTACT YOUR TILITE DEALER OR TILITE CUSTOMER SUPPORT AT (800) 545-2266 BEFORE ATTEMPTING TO USE THIS WHEELCHAIR. *IF YOU IGNORE THIS WARNING, YOU MAY FALL, TIP OVER OR LOSE CONTROL OF THE WHEELCHAIR AND SERIOUSLY INJURE YOURSELF OR OTHERS OR DAMAGE THE WHEELCHAIR.*

⚠ WARNING - WHEELCHAIR SELECTION

TILITE MANUFACTURES A WIDE VARIETY OF WHEELCHAIRS TO MEET THE VARIED NEEDS OF WHEELCHAIR USERS. HOWEVER, TILITE IS NOT YOUR HEALTH CARE ADVISOR, AND WE KNOW NOTHING ABOUT YOUR INDIVIDUAL CONDITION OR NEEDS. THEREFORE, THE FINAL SELECTION OF THE PARTICULAR MODEL, AND HOW IT IS ADJUSTED, AND THE TYPE OF OPTIONS AND ACCESSORIES NECESSARY REST SOLELY WITH YOU, THE WHEELCHAIR USER, AND THE HEALTH CARE PROFESSIONAL THAT IS ADVISING YOU. CHOOSING THE BEST CHAIR AND SETUP FOR YOUR SAFETY DEPENDS ON SUCH THINGS AS:

1. YOUR DISABILITY, STRENGTH, BALANCE AND COORDINATION;
2. THE TYPES OF HAZARDS YOU MUST OVERCOME IN DAILY USE (WHERE YOU LIVE AND WORK AND OTHER PLACES YOU ARE LIKELY TO USE YOUR CHAIR); AND
3. YOUR NEED FOR OPTIONS FOR YOUR SAFETY AND COMFORT (SUCH AS ANTI-TIPS, POSITIONING BELTS OR SPECIAL SEATING SYSTEMS).

IF YOU IGNORE THIS WARNING, YOU MAY ENDANGER YOUR HEALTH.

⚠ WARNING - TIE-DOWN RESTRAINTS

TILITE RECOMMENDS THAT WHEELCHAIR USERS NOT BE TRANSPORTED IN VEHICLES OF ANY KIND WHILE IN WHEELCHAIRS. AS OF THIS DATE, THE UNITED STATES DEPARTMENT OF TRANSPORTATION HAS NOT APPROVED ANY TIE-DOWN SYSTEM FOR TRANSPORTATION OF A USER WHILE IN A WHEELCHAIR IN A MOVING VEHICLE OF ANY TYPE. IT IS TILITE'S POSITION THAT USERS OF WHEELCHAIRS SHOULD BE TRANSFERRED INTO APPROPRIATE VEHICLE SEATING FOR TRANSPORTATION AND SHOULD USE THE RESTRAINTS MADE AVAILABLE BY THE AUTO INDUSTRY. TILITE CANNOT, AND DOES NOT, RECOMMEND ANY WHEELCHAIR TRANSPORTING SYSTEMS.

⚠ WARNING - SEATING RESTRAINTS

IT IS THE OBLIGATION OF YOUR DEALER AND THE HEALTH CARE PROFESSIONALS WHO ARE ADVISING YOU TO DETERMINE IF YOU REQUIRE A SEATING RESTRAINT OR POSITIONING SYSTEM IN ORDER TO ENSURE THAT YOU CAN SAFELY OPERATE YOUR WHEELCHAIR. SERIOUS INJURY CAN OCCUR IN THE EVENT OF A FALL FROM A WHEELCHAIR.

Note: The information contained in this document is subject to change without notice. An updated version of this Owner's Manual may be available at www.tilite.com

SAVE THIS MANUAL FOR FUTURE REFERENCE



Dear TiLite Customer:

We are glad that you have chosen to be part of the TiLite family. Making the best wheelchairs in the world is our mission. Over the years, we have achieved that mission by putting our heart and soul into every wheelchair that we design and build. Here are just a few examples of where that heart and soul comes from *and* where it leads:

- **We Are You:** From our designers and engineers to our sales people in the field, you will find chair users. When we design for you, we are designing for us.
- **TiFit:** We manufacture made-to-measure wheelchairs (ZR, ZRA, TR3 and TX) that perform to prosthetic standards of fit and function. We call this TiFit: Every dimension of the chair is made to the exact specifications of the individual who will be using the chair. The optimal fit of a TiFit chair brings unparalleled performance.
- **Choice Matters:** TiLite offers the most extensive range of options and components on a chair. More choices mean more ability to truly create a custom configuration of options to meet the widest variety of needs and to maximize function.
- **Customer Service:** TiLite's goal is to provide the ultimate service for the Ultimate Ride. The sale of a wheelchair does not mark the end of our relationship with our customers, it marks the beginning. We will always work with you, our customers, to ensure the highest levels of satisfaction.

What does all this mean for you? It means that your handmade TiLite wheelchair represents the latest in state-of-the-art design, aesthetics, and performance and combines the finest frame and component materials with sophisticated manufacturing and quality control procedures, ensuring you many years of exceptional performance and durability. Enjoy the ride.

Please take a moment to register this chair at tilite.com. This will allow us to better serve you should you have any questions regarding your TiLite.

On behalf of the TiLite Team, thank you for choosing TiLite.

A handwritten signature in blue ink that reads 'David'.

David Lippes
Founder, Chairman & CEO

REGISTER YOUR TiLITE

**Register online at TiLite.com
or
Complete and mail the form on the next page**

Why Should You Register:

- 1. Increase your use and enjoyment of your TiLite by receiving updates from TiLite with product information, maintenance tips and industry news.**
- 2. Enable TiLite to contact you or your health care provider if servicing is needed for your wheelchair.**
- 3. Provide your feedback to TiLite regarding your experience and needs, thereby enabling TiLite to further improve product designs.**

All information you provide to TiLite when you register will be protected by TiLite as required by applicable laws and regulations and will be used solely by TiLite.



PRODUCT REGISTRATION FORM

Register online at tilite.com or
complete and mail this form.

CUT ALONG LINE

Name: _____

Address: _____

City: _____ State/Province: _____

Zip/Postal Code: _____ Country: _____

FOLD HERE

Email: _____ Phone: _____

Model: _____ Serial #: _____

Purchased From: _____ Date of Purchase: _____

Method of purchase: check all that apply
 Medicare insurance Medicaid other _____

This product was purchased for use by: check one
 Self Parent Spouse other _____

Reasons for purchasing a TiLite
 reputation Dealer relative Friend therapist/Doctor
 Advertisement: Please Specify _____

Were your expectations met in the following areas? If not, please specify
Quality of Service: Yes No _____
Timeliness of Delivery: Yes No _____
Quality of Product: Yes No _____

FOLD HERE

What additional features, if any, would you like to see on this or future TiLite products?

CUT ALONG LINE



FOLD HERE



NO POSTAGE
NECESSARY
IF MAILED
IN THE
UNITED STATES

BUSINESS REPLY MAIL

FIRST-CLASS MAIL PERMIT 100 PASCO WA

POSTAGE WILL BE PAID BY ADDRESSEE

**TILITE
2701 WEST COURT ST
PASCO WA 99301-3911**

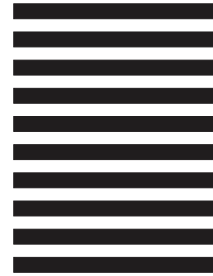

FOLD HERE

TiLite Product Registration Form

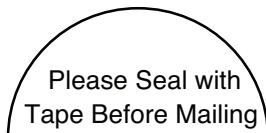

CUT ALONG LINE

CUT ALONG LINE



CONTENTS

CHAPTER 1: WARNINGS	1-1
GENERAL WARNINGS	1-1
A. SAFETY INSPECTIONS AND MAINTENANCE.....	1-1
B. ACCLIMATING TO YOUR NEW CHAIR.....	1-1
C. WEIGHT LIMITATION.....	1-1
D. PREVENTING ACCIDENTS AND INJURIES.....	1-1
E. CHANGING/ADJUSTING YOUR WHEELCHAIR.....	1-2
F. ENVIRONMENTAL FACTORS.....	1-2
G. STREET USE.....	1-2
H. TERRAIN.....	1-2
I. MOTOR VEHICLE SAFETY.....	1-3
J. WEIGHT TRAINING.....	1-3
K. OBTAINING ASSISTANCE.....	1-3
L. STANDING ON YOUR CHAIR.....	1-4
WARNINGS FOR SAFE USE OF YOUR WHEELCHAIR	1-4
A. LEARNING TO DO A “WHEELIE”.....	1-4
B. CLIMBING A CURB OR SINGLE STEP.....	1-5
C. CLIMBING A FLIGHT OF STAIRS.....	1-5
D. DESCENDING A CURB OR SINGLE STEP.....	1-5
E. DESCENDING A FLIGHT OF STAIRS.....	1-6
WARNINGS REGARDING FALLING AND TIPPING OVER	1-6
A. CENTER OF GRAVITY—STABILITY AND BALANCE.....	1-6
B. TRANSFERRING IN AND OUT OF YOUR WHEELCHAIR.....	1-7
C. DRESSING/UNDRESSING IN YOUR CHAIR.....	1-8
D. BENDING/LEANING/REACHING.....	1-8
E. MOVING BACKWARD.....	1-9
F. WHEELIES.....	1-9
G. OBSTACLES.....	1-9
H. CURBS/STEPS.....	1-10
I. HILLS/SLOPES/RAMPS.....	1-10
J. STAIRS.....	1-11
K. ESCALATORS.....	1-11
L. ASSISTANTS AND ATTENDANTS.....	1-11
WARNINGS REGARDING COMPONENTS AND OPTIONS	1-11
A. ANTI-TIPS.....	1-11
B. SEAT SLINGS/CUSHIONS.....	1-12
C. UPHOLSTERY FABRIC.....	1-12
D. SEATING SYSTEMS.....	1-13
E. POSITIONING OR SEAT BELTS.....	1-13
F. ARMRESTS.....	1-13
G. FOOTRESTS/HANGERS.....	1-14
H. REAR WHEELS.....	1-14
I. AXLES.....	1-14
J. PNEUMATIC TIRES.....	1-15
K. REAR WHEEL LOCKS.....	1-15
L. CASTER PIN LOCKS.....	1-15

M. PUSH HANDLES.....	1-16
N. FASTENERS.....	1-16
O. POWER DRIVE.....	1-16
P. UNAUTHORIZED PARTS AND ACCESSORIES.....	1-17

CHAPTER 2: SAFETY INSPECTION, MAINTENANCE & TROUBLESHOOTING.....2-1

INTRODUCTION.....	2-1
SAFETY INSPECTIONS AND MAINTENANCE.....	2-1
CLEANING.....	2-3
Cleaning the Frame.....	2-3
Cleaning the Upholstery.....	2-3
Axles and Moving Parts.....	2-3
STORAGE.....	2-3
TROUBLESHOOTING.....	2-4

CHAPTER 3: FOOTRESTS.....3-1

SAFE TREAD.....	3-1
TITANIUM FOOTREST with FLAT ABS COVER.....	3-2
Adjusting the Height/Replacing (TR and YR Series 2).....	3-2
Adjusting the Height/Replacing (TR Series 3).....	3-2
TITANIUM OPEN LOOP FOOTREST.....	3-3
ANGLE ADJUSTABLE FOOTREST.....	3-3
Adjusting the Angle.....	3-3
Adjusting the Height/Replacing (TR and YR Series 2).....	3-4
Adjusting the Height/Replacing (TR Series 3).....	3-4
ANGLE ADJUSTABLE HIGH MOUNT FOOTREST.....	3-5
Adjusting the Angle.....	3-5
Adjusting the Height/Replacing.....	3-5
FLIP BACK FOOTREST	3-5
Adjusting the Angle.....	3-6
Adjusting the Height/Replacing.....	3-6
BUCKLE ADJUSTABLE CALF STRAPS.....	3-6
ADJUSTABLE CALF STRAP/PADDED ADJUSTABLE CALF STRAP.....	3-6

CHAPTER 4: BACKRESTS AND PUSH HANDLES.....4-1

FOLDING ADJUSTABLE HEIGHT & ANGLE BACKREST (Titanium or Aluminum).....	4-1
Folding the Backrest.....	4-1
Unfolding the Backrest.....	4-1
Unfolding the Lock-Down Backrest.....	4-1
Adjusting the Backrest Lock Bracket (TR and YR Series 2).....	4-1
Adjusting if there is “Play” in the Backrest or Backrest Bracket (TR and YR Series 2).....	4-2
Adjusting the Backrest Mount (TR Series 3).....	4-3
Changing the Backrest Angle (TR and YR Series 2).....	4-3
Changing the Backrest Angle (TR Series 3).....	4-4
Adjusting the Backrest Height (TR and YR Series 2).....	4-5
Adjusting the Backrest Height (TR Series 3).....	4-8
Replacing the Backrest (TR and YR Series 2).....	4-9
Replacing the Backrest (TR Series 3).....	4-10
NON-FOLDING FIXED HEIGHT & ANGLE BACKREST.....	4-10
BOLT-ON PUSH HANDLES.....	4-10
Mounting.....	4-10
Removing.....	4-11

ADJUSTABLE HEIGHT PUSH HANDLES.....	4-11
Mounting.....	4-11
Removing.....	4-12

CHAPTER 5: ARMRESTS.....5-1

SWING AWAY ARMREST (TR and YR Series 2 prior to October 2010).....	5-1
Adjusting the Height of the Swing Away Armrest.....	5-1
Adjusting the Height of the Receiver.....	5-2
SWING AWAY ARMREST (TR and YR Series 2 after October 2010).....	5-2
Adjusting the Height of the Swing Away Armrest.....	5-3
Adjusting the Height of the Receiver.....	5-3
SWING AWAY ARMREST (TR Series 3).....	5-4
Adjusting the Angle.....	5-5
Adjusting the Height.....	5-5
DESK ARM with RIGID SIDE GUARD and DESK ARM with RIGID SIDE GUARD and TRANSFER LOOP	5-6
Adjusting the Armrest Height.....	5-6
Removing.....	5-6
Replacing.....	5-6
SWING AWAY FLIP-BACK ARMREST (TR Series 3).....	5-7
Adjusting the Armrest Height.....	5-8
Adjusting the Armrest Angle.....	5-9

CHAPTER 6: SIDE GUARDS.....6-1

CLOTH SIDE GUARDS.....	6-1
Removing/Replacing.....	6-1
RIGID REMOVABLE and QUAD REMOVABLE SIDE GUARDS (Aluminum and Carbon Fiber)..	6-1
Using Rigid Side Guards.....	6-1
Adjusting (TR and YR Series 2).....	6-2
Removing the Rigid Side Guard Assembly (TR and YR Series 2).....	6-2
Reinstalling the Rigid Side Guard Assembly (TR and YR Series 2).....	6-2
Adjusting (TR Series 3).....	6-3
Removing the Rigid Side Guard Assembly (TR Series 3).....	6-3
Reinstalling the Rigid Side Guard Assembly (TR Series 3).....	6-3
FOLD-DOWN RIGID SIDE GUARDS (Aluminum and Carbon Fiber) (TR and YR Series 2).....	6-4
Using Fold-Down Side Guards.....	6-4
Removing.....	6-4
Reinstalling.....	6-4
FOLD-DOWN RIGID SIDE GUARDS (Aluminum and Carbon Fiber) (TR Series 3).....	6-4
Using Fold-Down Side Guards.....	6-4
Removing.....	6-5
Reinstalling.....	6-5
FENDERED CARBON FIBER SIDE GUARD.....	6-5
Using Fendered Side Guards.....	6-5
ADJUSTABLE FENDERED SIDE GUARD (Aluminum) (TR Series 3).....	6-6
Mounting.....	6-6
Adjusting.....	6-7

CHAPTER 7: BACK UPHOLSTERY, SEAT UPHOLSTERY AND SEAT CUSHIONS.....7-1

VELCRO®-STYLE ADJUSTABLE BACK UPHOLSTERY.....	7-1
Adjusting the Tension.....	7-1
Replacing.....	7-1

TENSION ADJUSTABLE BY STRAPS BACK UPHOLSTERY.....	7-2
Adjusting the Tension.....	7-2
Replacing.....	7-3
CORBAC® ADJUSTABLE CONTOUR BACK SUPPORT.....	7-3
TENSION ADJUSTABLE BY STRAPS SEAT SLING UPHOLSTERY.....	7-3
Adjusting the Tension.....	7-3
Replacing the Upholstery.....	7-4
BOLT-ON SEAT SLING.....	7-4
Adjusting the Tension.....	7-4
Replacing the Upholstery.....	7-5
SEAT CUSHIONS.....	7-5
Replacing the Foam Insert in the TiLite Seat Cushion.....	7-5
VELCRO®-STYLE ADJUSTABLE SEAT BELT.....	7-5
Installation.....	7-6
Adjustment.....	7-7
Safety Check.....	7-7
Maintenance.....	7-7

CHAPTER 8: AXLE PLATES AND CAMBER PLUGS

(CENTER OF GRAVITY; REAR SEAT HEIGHT).....	8-1
STANDARD CAMBER MOUNTS.....	8-1
Adjusting the Center of Gravity (TR and YR Series 2).....	8-1
Replacing the Camber Tube (TR and YR Series 2).....	8-2
Adjusting the Center of Gravity (TR Series 3).....	8-3
Replacing the Camber Tube (TR Series 3).....	8-3
FROG LEGS® SUSPENSION.....	8-4
Adjusting the Center of Gravity.....	8-4
Replacing the Camber Tube.....	8-5
ADJUSTING TOE-IN/TOE-OUT.....	8-5
ADJUSTABLE CAMBER SYSTEM.....	8-6
Adjusting the Skewer Handle Tension.....	8-6
Changing the Camber.....	8-7
Adjusting Rear Wheel Spacing.....	8-7
Adjusting Toe-In/Toe-Out.....	8-8

CHAPTER 9: AXLES AND AMPUTEE ADAPTERS..... 9-1

STAINLESS and TITANIUM QUICK-RELEASE AXLES.....	9-1
Adjusting the Quick-Release Axle.....	9-1
QUAD QUICK-RELEASE AXLES.....	9-1
Adjusting the Quad Quick-Release Handle.....	9-1
Adjusting the “Play”.....	9-2
AMPUTEE ADAPTERS.....	9-3

CHAPTER 10: WHEEL LOCKS..... 10-1

COMPACT PUSH to LOCK	10-1
Adjusting.....	10-1
Replacing.....	10-1
COMPACT PULL to LOCK	10-2
Adjusting.....	10-2
Replacing.....	10-2
COMPACT PUSH to LOCK and COMPACT PULL TO LOCK WHEEL LOCKS with EXTENSION HANDLES	10-2

COMPACT SCISSOR LOCK.....	10-2
Adjusting.....	10-2
Replacing.....	10-3
UNI-LOCK.....	10-3
Adjusting.....	10-3
Replacing.....	10-4
Changing the Uni-Lock from the Push to the Pull Position.....	10-4
Repositioning the Handle of the Uni-Lock Wheel Lock.....	10-4
UNI-LOCK WITH EXTENSION HANDLES	10-6
ALUMINUM SCISSOR LOCK.....	10-6
Adjusting.....	10-6
Replacing.....	10-6

CHAPTER 11: CASTERS, FORKS AND CASTER PIN LOCKS.....11-1

CASTERS and FORKS.....	11-1
Replacing Casters.....	11-1
Replacing Forks.....	11-2
CASTERS with MONO FORKS (TR Series 3).....	11-2
Replacing Casters.....	11-2
Replacing Forks.....	11-2
CASTER PIN LOCKS (TR and YR Series 2).....	11-3
FLOATING CASTERS.....	11-3
FROG LEGS®.....	11-4
Replacing Casters.....	11-4
Replacing the Elastomer Shock.....	11-5
Replacing Frog Legs®.....	11-5

CHAPTER 12: REAR WHEELS.....12-1

QUICK-RELEASE AXLE.....	12-1
Removing.....	12-1
Replacing.....	12-1
QUAD QUICK-RELEASE AXLE.....	12-1
Removing.....	12-1
Replacing.....	12-1
HANDRIMS	12-2
PNEUMATIC TIRES and TUBES.....	12-2
SOLID TIRES.....	12-2
REAR WHEEL SPACERS.....	12-3
Adjusting Rear Wheel Spacing.....	12-3

CHAPTER 13: ANTI-TIPS.....13-1

REAR ANTI-TIPS.....	13-1
Adjusting.....	13-1
Mounting (TR and YR Series 2).....	13-1
Mounting (TR Series 3).....	13-2
USER-FRIENDLY REAR FLIP-UP ANTI-TIPS (TR and YR Series 2).....	13-4
Engaging.....	13-4
Disengaging.....	13-4
Adjusting.....	13-5
Removing.....	13-5
Mounting.....	13-5
USER-FRIENDLY ANTI-TIPS (TR Series 3).....	13-7
Engaging.....	13-7

Disengaging.....	13-7
Adjusting.....	13-8
Removing.....	13-8
Mounting.....	13-8
STANDARD TITANIUM 5TH WHEEL with SINGLE SWIVEL CASTER.....	13-10
Adjusting.....	13-10
QUICK-RELEASE TITANIUM 5TH WHEEL with SINGLE SWIVEL CASTER	13-10
Adjusting.....	13-10
5TH WHEEL SWIVEL CASTER.....	13-11
Adjusting the Height.....	13-11
FRONT ROLLER.....	13-11
Removing.....	13-11

GENERAL WARNINGS

A. SAFETY INSPECTIONS AND MAINTENANCE

⚠ WARNING

It is important to keep your wheelchair in proper working condition. Chapter 2 of this Manual outlines the safety inspections that you should make before each use of your chair, as well as weekly and quarterly inspections.

1. ALWAYS inspect and maintain your TiLite wheelchair strictly in accordance with the instructions and charts in Chapter 2.
2. If you detect a problem in the course of your inspections or maintenance, ALWAYS have the chair serviced or repaired to correct the problem **BEFORE** using the chair.
3. ALWAYS have your chair completely inspected and serviced by an authorized TiLite supplier at least once a year.
4. ALWAYS perform your safety inspections and any maintenance or adjustments while the chair is unoccupied (unless this Manual expressly states otherwise).

If you fail to inspect or maintain your wheelchair as directed in this Manual, you may fall, tip over or lose control of the wheelchair and seriously injure yourself or others or damage the wheelchair.

B. ACCLIMATING TO YOUR NEW CHAIR

⚠ WARNING

Each wheelchair is a unique piece of medical equipment, with unique handling, maneuvering and ride characteristics. Whether you are a new wheelchair user or have years of experience, you **MUST** take the time to acclimate to this particular chair before you begin riding. Start slowly and take the time to learn the handling, maneuvering and ride characteristics of this chair. For example, your previous chair may have been a heavier and less responsive chair, and, therefore, you may be used to using more force than is necessary to maneuver your TiLite chair.

If you ignore these Warnings, you may fall, tip over or lose control of the wheelchair and seriously injure yourself or others or damage the wheelchair.

C. WEIGHT LIMITATION

⚠ WARNING

TiLite wheelchairs have a weight limit of 250 pounds (113.6 kilograms). This weight limitation applies to the combined weight of the user and any items carried by the user. **DO NOT** exceed this weight limit.

If you exceed the limit, you may fall, tip over or lose control of the wheelchair and seriously injure yourself or others or damage the wheelchair.

D. PREVENTING ACCIDENTS AND INJURIES

⚠ WARNING

1. You **MUST** be properly and fully trained in the safe use of this wheelchair by your health care advisor **BEFORE** you use this chair.
2. Together with your health care advisor, you **MUST** analyze your level of function and ability and develop your own methods for safe use that best suit you based on your level of function and ability.
3. You **MUST** learn the limits of your ability and operate this wheelchair within such limits. This means you must **PRACTICE** the maneuvers you will need to perform, such as bending, reaching and transfers, until you know the limits of your ability. **ALWAYS** practice with the assistance of someone who can help you until you know what can cause, and how to avoid, a fall or tip-over. **NEVER** try a new maneuver on your own until you are sure you can do it safely.
4. **ALWAYS** learn as much as you can about the places where you will be using your chair before you get there. **ALWAYS** be alert for hazards and learn how to avoid them.
5. Anti-tips **MUST** be used with your wheelchair at all times. Because anti-tips are an option on this wheelchair, TiLite strongly recommends you order the anti-tips as they are an important safeguard for the wheelchair user.
6. Together with your health care advisor, you **MUST** analyze your medical condition to determine whether you are capable of using this chair safely and/or what options or accessories you will require in order to use this chair safely (e.g., pressure-relief cushions, seat belts).

CHAPTER 1: WARNINGS

If you ignore these Warnings, you may fall, tip over or lose control of the wheelchair and seriously injure yourself or others or damage the wheelchair.

E. CHANGING/ADJUSTING YOUR WHEELCHAIR

⚠ WARNING

1. Use extreme caution when changing or adjusting the configuration of your TiLite wheelchair. When you change or adjust the configuration, you may increase the risk of a tip-over. Therefore, you should consult your authorized TiLite dealer BEFORE you change or adjust the configuration. Further, TiLite recommends that you use anti-tips at all times, and this is particularly true after you have changed or adjusted the configuration of your chair.
2. Unauthorized modifications to your chair, or the use of parts not supplied or approved by TiLite, may change the chair structure, may cause a safety hazard, including an increased risk of a tip-over, and will void the warranty.

If you ignore these Warnings, you may fall, tip over or lose control of the wheelchair and seriously injure yourself or others or damage the wheelchair.

F. ENVIRONMENTAL FACTORS

⚠ WARNING

1. Riding your TiLite wheelchair on wet, icy or other slick surfaces increases the risk of losing control of the wheelchair or tipping over. Use extra care if you must ride your chair on any such surface. If you have any doubt about your ability to negotiate a particular surface, ALWAYS ask for assistance.
2. Titanium does not rust or corrode. Aluminum does not rust, but it will corrode. However, contact with water or excess moisture may still damage parts or components of your TiLite wheelchair that are made from other materials and could cause such parts or components to fail. Therefore, DO NOT:
 - a. use your chair in a shower, pool or other body of water,
 - b. leave your chair in a damp location, or
 - c. fail to dry your chair as soon as you can if it gets wet or if you use water to clean it.

If you ignore these Warnings, you may fall, tip over or lose control of the wheelchair and seriously injure yourself or others or damage the wheelchair.

G. STREET USE

⚠ WARNING

1. As a wheelchair rider, you MUST obey all traffic rules pertaining to pedestrians (use of crosswalks, etc.). Most states do not permit wheelchairs to be ridden on public roads, streets or highways (*i.e.*, as one would drive a car), so you should not do so without first consulting the traffic laws in your own state. Even if legal, riding your wheelchair on public roads, streets or highways is extremely dangerous and is not recommended.
2. At all times when riding your wheelchair in public areas (sidewalks, crosswalks, parking lots, etc.), be very alert to the danger of motor vehicles.
3. At night, or when lighting is poor, use reflective tape on your chair and clothing.
4. Due to your low position, it may be hard for drivers to see you. This is particularly true in situations where drivers may be driving in reverse, such as parking lots. If at all possible, make eye contact with drivers before you go forward. When in doubt, yield until you are sure it is safe, even if you have the right-of-way.

If you ignore these Warnings, you may fall, tip over or lose control of the wheelchair and seriously injure yourself or others or damage the wheelchair.

H. TERRAIN

⚠ WARNING

Your TiLite wheelchair is designed for riding over firm, relatively smooth surfaces such as concrete and asphalt outdoors and indoor flooring (wood, tile, etc.) and carpeting. Your TiLite wheelchair is NOT designed for riding over sand, loose soil or rough terrain. Do NOT operate your chair in such terrain. You may damage the wheels or axles or loosen fasteners of your chair.

If you ignore these Warnings, you may fall, tip over or lose control of the wheelchair and seriously injure yourself or others or damage the wheelchair.

I. MOTOR VEHICLE SAFETY

△ WARNING

TiLite wheelchairs are NOT designed to be used for seating in a motor vehicle, and TiLite wheelchairs do NOT meet Federal standards for motor vehicle seating.

1. NEVER sit in your chair while in any type of moving vehicle (bus, automobile, van, truck, boat, train, etc.). In an accident or sudden stop, you may be thrown from the chair. In an accident or sudden stop, a wheelchair seat belt will NOT prevent injuries and may, in fact, cause injuries.
2. ALWAYS transfer to an approved vehicle seat before the vehicle begins moving.
3. ALWAYS secure yourself in the approved vehicle seat using the proper seating restraints (in a motor vehicle, lap/shoulder belts; in a plane, lap belts, etc.).
4. NEVER transport your chair in the front seat of a vehicle. Movements of the vehicle may cause the chair to shift and interfere with the driver's ability to control the vehicle.
5. When transporting your chair in a moving vehicle, ALWAYS secure your chair so that it cannot roll or shift. In most cases, stowing it in the trunk is the safest alternative.
6. NEVER use any chair that has been involved in a motor vehicle accident. A wheelchair that has been involved in a motor vehicle accident may be damaged in ways that are not readily apparent and which could cause the chair to fail in use.

If you ignore these Warnings, you may fall, tip over or lose control of the wheelchair and seriously injure yourself or others or damage the wheelchair.

J. WEIGHT TRAINING

△ WARNING

NEVER use your TiLite wheelchair for weight training. When your chair was set up with the assistance of your health care advisor, your center of gravity was determined based on your weight, the configuration of your chair and your abilities. If you engage in weight training activities in your chair, you are altering the total weight supported by your chair and the distribution of that weight. The center of gravity of your chair may not be appropriate with the additional weight or with the different distribution of weight, which may cause the chair to tip over. The additional weight could exceed the weight limit for the chair and damage the chair. If you intend to engage in weight training, TiLite recommends that you utilize weight training equipment with built-in seating and that you transfer to that seating rather than using your chair.

If you ignore these Warnings, you may fall, tip over or lose control of the wheelchair and seriously injure yourself or others or damage the wheelchair.

K. OBTAINING ASSISTANCE

△ WARNING

For The Wheelchair User:

ALWAYS make sure that each person who assists you reads and understands this entire Manual, especially the Warnings in Chapter 1.

For Attendants/Assistants:

1. ALWAYS work with the user's health care advisor to learn safe methods to assist the wheelchair user and to determine which methods are best suited to your abilities and those of the user.
2. ALWAYS communicate to the user what you plan to do before you do it and explain what you expect the user to do while you are taking such action. This will put the user at ease and reduce the risk of an accident due to a miscommunication.
3. ALWAYS use good posture and proper body mechanics in order to avoid injury to your back.
4. When you lift or support the user or tilt the chair, ALWAYS bend your knees slightly and keep your back as upright and straight as you can.
5. Wheelchair push handles are designed to provide a secure location for an attendant to grip the rear of the wheelchair to prevent a fall or tip-over. ALWAYS make sure the wheelchair has push handles and ALWAYS use them. REGULARLY check to make sure the push handle grips are securely seated on the back canes so they will not rotate or slip off.

CHAPTER 1: WARNINGS

6. If you are going to tilt the chair backward, ALWAYS remind the user to lean back.
7. If you are going to descend a curb or single step, ALWAYS lower the chair slowly in one easy movement. NEVER let the chair drop the last few inches to the ground. This may damage the chair or injure the user.
8. ALWAYS become familiar with the user's wheelchair and all of its parts and components. In particular, be very aware of any removable parts. Removable parts must NEVER be used for a hand-hold or lifting supports because they may inadvertently release, resulting in possible injury to the user and/or assistant.
9. Anti-tips may present a tripping hazard to the attendant. To avoid tripping over the anti-tips, unlock and rotate anti-tip tubes up, out of the way. However, if you must leave the user unattended, even for a moment, ALWAYS rotate the anti-tips back into the down position and lock the rear wheels using the wheel locks. This will reduce the risk of a tip-over or loss of control of the chair.
10. When you are learning a new assistance technique, ALWAYS have an experienced attendant help you before attempting it on your own.

If you ignore these Warnings, you may fall, tip over or lose control of the wheelchair and seriously injure yourself or others or damage the wheelchair.

L. STANDING ON YOUR CHAIR

⚠WARNING

Your TiLite wheelchair has been designed for use as a wheelchair, not as a step ladder. NEVER stand on your TiLite wheelchair.

If you ignore these Warnings, you may fall, tip over or lose control of the wheelchair and seriously injure yourself or others or damage the wheelchair.

WARNINGS FOR SAFE USE OF YOUR WHEELCHAIR

A. LEARNING TO DO A “WHEELIE”

⚠WARNING

DO NOT attempt to perform a “wheelie” in your wheelchair because of the dangerous nature of this kind of maneuver.

TiLite recognizes that some wheelchair users will ignore this warning. If you should choose to ignore this warning, you should follow these steps to help learn to do a “wheelie” as safely as possible (but doing a “wheelie” is never completely safe and TiLite assumes no responsibility for any injury you may sustain as a result of doing a “wheelie”):

1. Read and follow the Warning for “WHEELIES” on page 1-9.
2. NEVER attempt to learn how to do a “wheelie” without the assistance of someone strong enough to catch you should you start to tip over (a “spotter”). Your spotter should read and be completely familiar with this entire Manual, especially this Warning and the Warning for “WHEELIES” on page 1-9.
3. Instruct your spotter to stand at the rear of your chair. Your spotter must be agile enough to move with you and your chair to prevent a tip-over.
4. Instruct your spotter to keep his or her hands BENEATH the push handles or backrest rigidizer bar so that he or she is ready to catch you if you exceed the balance point of the rear wheels and start to tip over backward.
5. When your spotter is in position and is ready, place your hands on the forward portion of the handrims. Using the handrims, make a quick BACKWARD movement of the rear wheels, quickly followed by a hard FORWARD thrust. This will tilt the chair up on the balance point of the rear wheels. DO NOT remove your hands from the handrims after either the backward movement or forward thrust so that you can continue to manipulate the rear wheels to maintain your balance on the two rear wheels.
6. Use SMALL movements of the handrims to maintain your balance on the two rear wheels.

If you ignore these Warnings, you may fall, tip over or lose control of the wheelchair and seriously injure yourself or others or damage the wheelchair.

B. CLIMBING A CURB OR SINGLE STEP

⚠WARNING

1. NEVER attempt to negotiate a curb or single step without assistance.
2. Instruct your assistant to stand at the rear of your wheelchair, with the front of the wheelchair facing the obstacle. NEVER attempt to negotiate any such obstacle backward.
3. Instruct your assistant to tilt the chair up on the rear wheels so that the front casters clear the curb or step.
4. Instruct your assistant to slowly move the chair forward and to gently lower the front casters to the upper level as soon as you are sure that they are beyond the edge of the curb or step.
5. Instruct your assistant to continue to roll the chair forward until the rear wheels contact the face of the curb or step.
6. Instruct your assistant to lift and roll the rear wheels up to the upper level.

If you ignore these Warnings, you may fall, tip over or lose control of the wheelchair and seriously injure yourself or others or damage the wheelchair.

C. CLIMBING A FLIGHT OF STAIRS

⚠WARNING

DO NOT climb a flight of stairs with the user in the wheelchair.

However, TiLite recognizes that wheelchair users may, on occasion, have no other choice. Only if you have no alternative, you should follow these steps to climb up a flight of stairs.

1. NEVER attempt to negotiate more than one step unless you have two (2) able-bodied adult assistants.
2. ALWAYS position the chair and rider facing away from the stairs, with one assistant at the rear (facing away from the stairs) and one at the front of the chair (facing the rider).
3. The assistant at the rear of the chair is in control of this procedure. He or she must tilt the chair back to its balance point on the rear wheels. NEVER attempt to lift a wheelchair by lifting on any removable (detachable) parts, including upholstery and removable push handles or push handle grips.
4. The second assistant at the front must firmly grasp a non-detachable part of the front frame (but NOT swing-away hangers) with both hands and lift the chair up and over one stair at a time.
5. Each assistant then carefully moves up to the next stair.
6. Repeat steps 1 through 5 for each stair, until you reach the landing.
7. When you reach the landing, the assistants should roll the chair backward on the two rear wheels until the front casters have cleared the last step, at which point the assistants can gently lower the front casters to the landing.

If you ignore these Warnings, you may fall, tip over or lose control of the wheelchair and seriously injure yourself or others or damage the wheelchair.

D. DESCENDING A CURB OR SINGLE STEP

⚠WARNING

1. NEVER attempt to negotiate a curb or single step without assistance.
2. When you are still several feet from the edge of the curb or step, instruct your assistant to stand at the rear of your wheelchair and turn it around so you are facing AWAY from the obstacle.
3. NEVER attempt to negotiate any such obstacle facing forward.
4. Instruct your assistant to carefully step backwards, pulling the chair backwards, until he or she is off the curb or stair and standing on the lower level. The assistant should watch his or her step over his or her shoulder when backing up in this manner.
5. Instruct your assistant to carefully pull the chair backward until the rear wheels reach the edge of the curb or step, and to then allow the rear wheels to slowly roll down to the lower level.
6. Instruct your assistant that, when the rear wheels are safely on the lower level, he or she may then tilt the chair backward to the balance point of the rear wheels, thereby raising the front casters off the upper level.
7. Instruct your assistant to slowly roll the chair backward on the rear wheels, taking small steps until the front casters have cleared the step or curb and, when clear, to gently lower the front casters to the ground at the lower level.

If you ignore these Warnings, you may fall, tip over or lose control of the wheelchair and seriously injure yourself or others or damage the wheelchair.

CHAPTER 1: WARNINGS

E. DESCENDING A FLIGHT OF STAIRS

⚠WARNING

DO NOT descend a flight of stairs with the user in the wheelchair.

However, TiLite recognizes that wheelchair users may, on occasion, have no other choice. Only if you have no alternative, you should follow these steps to descend a flight of stairs.

1. NEVER attempt to negotiate more than one step unless you have two (2) able-bodied adult assistants.
2. ALWAYS position the chair and rider facing down the stairs, with one assistant at the rear (facing down the stairs) and one at the front of the chair (facing the rider).
3. The assistant at the rear of the chair is in control of this procedure. He or she must tilt the chair back to its balance point on the rear wheels and roll it to the edge of the first step. NEVER attempt to lift a wheelchair by lifting on any removable (detachable) parts, including upholstery and removable push handles or push handle grips.
4. The second assistant at the front must stand at the third step from the top and firmly grasp a non-detachable part of the front frame (but NOT swing-away hangers) with both hands. The second assistant must lower the chair one stair at a time by letting the rear wheels roll over the stair edge. Each assistant then carefully moves down to the next stair.
5. Repeat steps 1 through 4 for each stair, until you reach the ground level.
6. When you reach the ground level, the first assistant should carefully lower the front casters to the ground.

If you ignore these Warnings, you may fall, tip over or lose control of the wheelchair and seriously injure yourself or others or damage the wheelchair.

WARNINGS REGARDING FALLING AND TIPPING OVER

A. CENTER OF GRAVITY—STABILITY AND BALANCE



⚠WARNING

Most falls or tip-overs occur when you go beyond the center of gravity of you and your wheelchair. TiLite wheelchairs are designed to remain stable and upright in normal daily use and activities so long as you do not exceed the center of gravity.

Every movement you make in your chair, and the rapidity with which you move, will have an affect on your center of gravity. The more you shift your body weight and the greater the speed at which you shift it, the greater the impact on your center of gravity in your chair.

There is a point where your wheelchair will tip forward or backward or to the side—which is a function of your center of gravity in the chair—its center of balance and stability. The type of chair, the setup of your chair, the options on your chair and the changes you make to the setup or options will all affect the center of gravity and therefore the stability of the chair. As the stability decreases, the risk of a fall or tip-over increases.

Set forth below is a list of various types of adjustments that you may be able to make to your wheelchair, depending on the wheelchair model you own, and a brief description of how those adjustments will affect your center of gravity:

1. The position of the rear wheels is the most significant factor affecting your center of gravity. The more you move the rear wheels forward, the more likely your chair will tip over backward.
2. The distance between the rear wheels. The less distance between the rear wheels, the greater the likelihood your chair will tip over to the side.
3. The amount of rear wheel camber. The less camber, the greater the likelihood your chair will tip over to the side.

4. The height of your seat. As you raise the height of your seat, you raise your center of gravity and increase the likelihood of all types of tip-overs.
5. The angle of your seat. As you increase the angle of your seat (relative to the floor), your position in the chair is shifted toward the rear of the chair, increasing the likelihood your chair will tip over backward.
6. The angle of your backrest. As you increase the angle of your backrest (relative to the seat), your position in the chair is shifted toward the rear of the chair, increasing the likelihood your chair will tip over backward.
7. The height of your seat back. As you lower the height of your seat back, you make it easier to lean back in your chair, which in turn shifts your center of gravity rearward and increases the likelihood your chair will tip over backward.
8. The position of your front casters. As you move your front casters rearward on the frame (toward the rear wheels), you increase the likelihood your chair will tip over forward.

Other factors will affect your center of gravity:

1. A change in your body position, posture or weight distribution. For example, if you lean forward you shift the center of gravity forward and increase the likelihood of tipping over forward.
2. Riding your chair on a ramp or slope. On an up-slope, your weight shifts to the rear and a backward tip-over becomes more likely. On a down-slope, your weight shifts to the front of the chair and a forward tip-over becomes more likely.
3. The use of a backpack or other options, and the amount of weight added by those options. For example, carrying a lot of weight in a backpack will shift the center of gravity rearward and increase the likelihood of tipping over backward. However, using a TiLite seat pouch beneath the seat sling to carry heavier items will lower your center of gravity and reduce, but not eliminate, your risk of a tip over.

In order to reduce the risk of a tip-over, you should:

1. CONSULT your doctor, nurse or therapist to find out what axle and caster position and other chair configuration options are best for you.
2. CONSULT your authorized TiLite dealer BEFORE you modify or adjust your wheelchair. Often, an adjustment you wish to make can be offset by another that you have not considered. For example, you may want to adjust the back angle rearward, which will increase the likelihood of a rear tip-over. You might not think you could counteract this tendency by moving the rear wheels backward. Your authorized TiLite dealer will be able to give you expert, personalized advice in such matters. See “Changing/Adjusting Your Wheelchair” on page 1-2.
3. ALWAYS have someone assist you until you learn your chair’s balance points and are completely comfortable in your ability to operate your chair under all conditions so as to avoid tip-overs.
4. ALWAYS use anti-tips. See “Changing/Adjusting Your Wheel Chair” on page 1-2.

If you ignore these Warnings, you may fall, tip over or lose control of the wheelchair and seriously injure yourself or others or damage the wheelchair.

B. TRANSFERRING IN AND OUT OF YOUR WHEELCHAIR

⚠ WARNING

Transferring in or out of your wheelchair is one of the most dangerous things you can attempt relating to your wheelchair. It requires good balance, agility and upper body conditioning. At some point in every transfer, there is no wheelchair seat beneath you and the seat, bed, etc. to or from which you are transferring is not beneath you either.

Important rules that will help to reduce the risk of a fall during a transfer are discussed below:

1. ALWAYS work with your health care advisor to learn safe transfer methods.
2. ALWAYS ask your health care advisor to teach you proper body positioning during a transfer and how to support yourself during a transfer.
3. ALWAYS have someone assist you when you transfer until you have learned how to transfer safely and have developed the upper body strength and coordination to transfer safely.
4. ALWAYS move your chair as close as you can to the seat (bed, etc.) to which you are transferring. If possible, use a transfer board.

CHAPTER 1: WARNINGS

5. ALWAYS lock the rear wheels using wheel locks before you transfer. This keeps the rear wheels from rolling. If your wheelchair is equipped with caster pin locks, ALWAYS lock them before you transfer. Caster pin locks keep the front casters from rotating (but not from rolling). NOTE: Wheel locks and caster pin locks will NOT keep your chair from sliding away from you or tipping.
6. If your wheels have pneumatic (inflatable) tires, ALWAYS make sure to keep the tires properly inflated at all times. The wheel locks may slip if the tire pressure is low, which may cause the chair to roll unexpectedly during a transfer.
7. ALWAYS rotate the front casters as far forward as possible and turn them to the seat (bed, etc.) to which you are transferring.
8. ALWAYS remove the wheelchair armrests, or swing them out of the way, so they do not impede your movement during the transfer.
9. If possible, ALWAYS remove the footrests, or swing them out of the way, to ensure your feet do not get caught between the footrests. TiLite strongly recommends that you place your feet on the floor when you are transferring to or from your chair.
10. NEVER put your weight on the footrests when you are transferring to or from your chair because this may cause the chair to tip over and/or roll away.
11. When transferring into your chair, ALWAYS transfer as far back onto your seat as possible in order to reduce the risk that the chair will tip over or move away from you causing you to fall.
12. If possible, ALWAYS try to avoid falling into your chair uncontrollably when transferring into your chair. This places undue stress on your chair's components, and if your chair does start to move or tip you will not be ready to regain control.

If you ignore these Warnings, you may fall, tip over or lose control of the wheelchair and seriously injure yourself or others or damage the wheelchair.

C. DRESSING/UNDRESSING IN YOUR CHAIR

⚠WARNING

When you engage in activities while seated in your chair such as dressing or undressing or changing your clothes, your weight will shift. Since your attention will be directed to the activity in question, your risk of falling or tipping over is increased. To reduce this risk, get dressed or undressed or change your clothes while seated in a regular chair or on a bed. If you must get dressed or undressed or change your clothes while seated in your wheelchair:

1. ALWAYS rotate the front casters so they are trailing forward. This makes the chair more stable. NOTE: To get your front casters to trail forward, first move your chair forward and, second, back up. By moving backward, your front casters will rotate and trail forward.
2. ALWAYS lock your anti-tips in the down position so the risk of a backward tip-over is minimized. If your chair does not have anti-tips, back it up against a wall and lock both rear wheels using your wheel locks.
3. If your chair is equipped with caster pin locks, ALWAYS engage them.

If you ignore these Warnings, you may fall, tip over or lose control of the wheelchair and seriously injure yourself or others or damage the wheelchair.

D. BENDING/LEANING/REACHING

⚠WARNING

When you bend, reach or lean from your chair you will affect the center of balance of your chair. Therefore, bending, reaching or leaning may cause you to fall or tip over. In order to avoid falling or tipping over, you must determine your particular safety limitations given the configuration of your chair and your body weight and type. To do this, practice bending, reaching and leaning activities (and various combinations of such activities) under the supervision of your health care advisor. Do this BEFORE attempting active use of your chair. The following will help you avoid falling or tipping over when bending, reaching or leaning from your chair:

1. NEVER bend, reach or lean in a way that requires you to move forward in your seat.
2. ALWAYS keep your buttocks in contact with the backrest and the seat cushion when bending, reaching or leaning.
3. NEVER shift your weight in the same direction you are bending, reaching or leaning.
4. NEVER reach or lean to the rear unless your chair has anti-tips locked in place.

5. NEVER reach with both hands. By keeping one hand free, you may be able to catch yourself to prevent a fall if the chair starts to tip.
6. NEVER reach or lean over the top of the seat back. If you do so you may damage the seat back tubes, which could cause you to fall.
7. ALWAYS move your chair as close as possible to the object you are trying to reach.
8. NEVER shift your weight to the footrests.
9. NEVER try to pick up an object from the floor by reaching down between your knees. You are less likely to tip over if you reach to the side of your chair when picking up an object on the floor.
10. DO NOT lock the rear wheels when bending, reaching or leaning backward. Locking the rear wheels creates a tip point and makes falling or tipping over more likely.
11. When bending or leaning, ALWAYS grasp one rear wheel with one hand. This will help to prevent a fall if the chair starts to tip over.
12. ALWAYS rotate the front casters until they are trailing forward. This will make the chair more stable. NOTE: To get your front casters to trail forward, first move your chair forward past the object you want to reach and, second, back up alongside the object. By moving backward, your front casters will rotate and trail forward.

If you ignore these Warnings, you may fall, tip over or lose control of the wheelchair and seriously injure yourself or others or damage the wheelchair.

E. MOVING BACKWARD

⚠ WARNING

When you propel backward, you will tend to shift your weight backward, making a tip-over more likely. In addition, you may be unable to see an obstruction that could block one of your wheels and cause a tip-over. Therefore, use extreme caution when propelling backward. If you must propel backward:

1. ALWAYS propel slowly with smooth, short strokes.
2. MAKE frequent stops to check for obstructions in your path.
3. If your chair has anti-tips, ALWAYS make sure to lock them in place.

If you ignore these Warnings, you may fall, tip over or lose control of the wheelchair and seriously injure yourself or others or damage the wheelchair.

F. WHEELIES

⚠ WARNING

Balancing in your chair on just the rear wheels with the front casters in the air is known as doing a “wheelie.” DOING A WHEELIE IS DANGEROUS. A fall or tip-over is very likely. However, if you can do a “wheelie” safely, you may be able to overcome curbs and obstacles that would otherwise impede you.

NEVER attempt to learn to do a “wheelie” without first consulting your health care advisor to make sure you are a good candidate to learn to do a “wheelie.” NEVER attempt to learn to do a “wheelie” without an assistant that can catch you if you should happen to start to fall. NEVER attempt to learn to do a “wheelie” unless you are a skilled rider of this chair. See “Learning to do a ‘Wheelie’” on page 1-4.

If you ignore these Warnings, you may fall, tip over or lose control of the wheelchair and seriously injure yourself or others or damage the wheelchair.

G. OBSTACLES

⚠ WARNING

When riding outdoors, uneven pavement, sidewalk irregularities, potholes and other obstacles and road hazards can be dangerous. When riding indoors, doorway thresholds, plush carpeting and other obstacles can be dangerous. In order to avoid these risks:

1. ALWAYS be alert for such dangers.
2. ALWAYS scan the area ahead of you as you ride.
3. REMOVE or cover threshold strips between rooms.

CHAPTER 1: WARNINGS

4. INSTALL ramps at entry or exit doors from your residence. Make sure the transition from such ramps to the pavement or other surface is smooth and does not have an abrupt drop-off.
5. ALWAYS make sure the floors where you live and work are level.
6. KEEP all floors where you live and work free of obstacles and hazards.
7. When riding UP and over an obstacle, lean your upper body slightly FORWARD.
8. When riding DOWN from a higher to a lower level, press your upper body BACKWARD lightly.
9. ALWAYS keep both hands on the handrims as you go over an obstacle.
10. NEVER push or pull on any object, such as a door knob or door jamb or furniture, in order to propel your chair.
11. If your chair has anti-tips, lock them in place before you go UP over an obstacle.

If you ignore these Warnings, you may fall, tip over or lose control of the wheelchair and seriously injure yourself or others or damage the wheelchair.

H. CURBS/STEPS

⚠ WARNING

Curbs and steps are extremely dangerous obstacles.

1. NEVER attempt to go up or down a single curb or step without an assistant UNLESS:
 - a. you are a very skilled rider of your chair; and
 - b. you have previously learned to safely do a “wheelie” in your chair; and
 - c. you are sure you have the strength and balance to control your chair during any such maneuver.
2. ALWAYS unlock and rotate anti-tips up and out of the way so they do not prevent you from executing this maneuver.
3. Even if you are a highly skilled rider, NEVER attempt to climb or descend a curb or step more than 4” high.
4. ALWAYS go straight up or down a curb or step. NEVER climb or descend at an angle.
5. ALWAYS be aware that the impact of dropping down from a curb or step can damage your chair or cause components to become loose. If you perform such maneuvers, inspect your chair more frequently.

If you are not highly skilled at tilting the chair, or the step or the curb is more than 4” high, ALWAYS have an assistant help you negotiate curbs and steps. Your assistant must first read the Warnings contained in this Manual in their entirety, especially the sections titled “Climbing a Curb or Single Step”, “Climbing a Flight of Stairs”, “Descending a Curb or Single Step” and “Descending a Flight of Stairs” on pages 1-4 to 1-6.

If you ignore these Warnings, you may fall, tip over or lose control of the wheelchair and seriously injure yourself or others or damage the wheelchair.

I. HILLS/SLOPES/RAMPS

⚠ WARNING

The center of balance of your chair is affected by the slope of the surface over which you are riding. Because your center of balance will be affected, your chair will be less stable when it is at an angle. This is especially true when riding on a slope sideways. Furthermore, do not assume anti-tips will prevent a fall or tip-over under these conditions. The following rules may help to avoid a fall or tip-over:

1. ALWAYS go up or down a slope, hill or ramp as straight as possible. If you try to cut the corner, you will be traversing the slope, hill or ramp sideways to the slope and your risk of tipping over sideways will increase.
2. NEVER use your chair on a slope greater than 10%—a slope with an elevation greater than one foot in height for every ten feet in length.
3. NEVER stop on a steep slope. If you stop on a steep slope, you may not be able to maintain control of the chair.
4. NEVER use rear wheel locks as a brake to slow or stop your chair. Wheel locks are NOT brakes. Doing so will most likely cause the chair to veer out of control.
5. NEVER try to turn around or change direction when going up or down a slope.
6. ALWAYS stay in the CENTER of a ramp.
7. NEVER start up or down a ramp unless you are certain the ramp is wide enough for its entire length so your wheels will not fall off the edge.
8. In order to control your speed, ALWAYS keep pressure with your hands on the handrims when going down a hill, slope or ramp. DO NOT go too fast. Excessive speed may cause you to lose control of your chair, or it may cause your casters to flutter which can cause a fall or tip-over.

9. ALWAYS lean or press your body in the UPHILL direction. This will help shift your weight to counteract the change in the center of balance caused by the hill, slope or ramp.
10. ALWAYS ask for assistance if you have any concerns at all about your ability to maintain safe control of your chair on a hill, slope or ramp.
11. ALWAYS be alert for wet or slippery conditions or surfaces, any changes in the grade of the slope (such as a lip, bump or depression), and any drop-off or lip at the bottom of a slope. For example, even a 3/4 inch lip at the bottom of a ramp can cause the front casters to stop and cause the chair to tip forward.
12. Ramps at your home and work must meet all legal requirements for your area, including building codes. If you are having a ramp installed at your home or work, ALWAYS make sure it complies with local legal requirements.

If you ignore these Warnings, you may fall, tip over or lose control of the wheelchair and seriously injure yourself or others or damage the wheelchair.

J. STAIRS

⚠ WARNING

NEVER use your wheelchair on stairs without the assistance of at least two (2) able-bodied assistants or attendants and ONLY AFTER such assistants or attendants have read and understand the Warnings “Climbing a Flight of Stairs” and “Descending a Flight of Stairs” on pages 1-5 to 1-6.

If you ignore these Warnings, you may fall, tip over or lose control of the wheelchair and seriously injure yourself or others or damage the wheelchair.

K. ESCALATORS

⚠ WARNING

NEVER use your wheelchair on an escalator, not even with an assistant or attendant.

If you ignore these Warnings, you may fall, tip over or lose control of the wheelchair and seriously injure yourself or others or damage the wheelchair.

L. ASSISTANTS AND ATTENDANTS

⚠ WARNING

Before you permit any person to assist you in any aspect of riding your wheelchair, you MUST require that the assistant or attendant fully read, understand and follow the Warnings contained in this Manual.

If you ignore these Warnings, you may fall, tip over or lose control of the wheelchair and seriously injure yourself or others or damage the wheelchair.

WARNINGS REGARDING COMPONENTS AND OPTIONS

A. ANTI-TIPS

⚠ WARNING

Anti-tips are an optional accessory that can help to prevent your chair from tipping over backward. However, even the use of anti-tips will not guarantee that your chair will not tip over backward. Also, they will not prevent your chair from tipping over sideways or forward.

TiLite strongly recommends you use anti-tips with your wheelchair. This is most especially true:

- a. if you are a new wheelchair rider; or
- b. even if you are an experienced rider but you are switching to a new wheelchair, regardless of whether the prior chair was as lightweight as your TiLite; or
- c. even if you are an experienced rider in your TiLite chair but you have made any modifications or adjustments to the configuration of your chair, such as changing the position of the front or rear wheels, changing the seat height, changing the camber or changing the seat or back angle. Any modification or change to

CHAPTER 1: WARNINGS

- your chair can make it easier to tip over and you should use anti-tips until you have adapted to the modified configuration; or
- d. even if you are an experienced rider in your TiLite chair but your physical condition has changed.

In order to properly use your anti-tips, please follow the following rules:

1. Your anti-tips should be between 1-1/2 inches to 2 inches off the ground when they are locked in place in the “down” position.
2. If your anti-tips are set too LOW, they may “catch” on obstacles that you can expect to encounter in normal wheelchair use. If this happens, you may tip over and fall.
3. If your anti-tips are set too HIGH, their ability to prevent a backward tip-over will be limited and they may not prevent a tip-over at all.
4. ALWAYS keep your anti-tips locked in place in the “down” position unless:
 - a. You have an attendant (but your attendant must rotate the anti-tips into the “down” position whenever he or she leaves you unattended in your chair, even for a moment), or
 - b. You have to climb or descend a curb or step or overcome an obstacle. Even if this is the case, only unlock the anti-tips if you can safely climb or descend the curb or step or overcome the obstacle and make sure the anti-tips are locked in the “up” position.

If you ignore these Warnings, you may fall, tip over or lose control of the wheelchair and seriously injure yourself or others or damage the wheelchair.

B. SEAT SLINGS/CUSHIONS

⚠ WARNING

TiLite seat slings (which are standard equipment) and cushions (which are optional equipment) are not designed for the relief of pressure. If you have pressure sores, or are at risk to get them, you may need a special pressure-relieving cushion or other seating system. If you have pressure sores, consult with your doctor immediately. If you are at risk to develop pressure sores or do not know if you are at risk, consult with your doctor as to the most appropriate seating system for you. TiLite has NO information about your medical condition and assumes no responsibility should you choose the wrong seating system for your medical needs. You MUST regularly check your seat sling while you are seated in your wheelchair to ensure that the tension is properly adjusted so that your weight does not cause the seat sling to touch the cross tubes beneath the seat sling.

TiLite also offers a limited number of seat cushions manufactured by other manufacturers. However, the selection of any of these products is a decision to be made by you and your doctor or therapist. TiLite has NO information about your medical condition and assumes no responsibility should you choose the wrong seating system for your medical needs.

If you ignore these Warnings, you may develop pressure sores, which can be a life-threatening complication from wheelchair use.

C. UPHOLSTERY FABRIC

⚠ WARNING

1. If the fabric of your seat sling or seat back becomes worn or torn, ALWAYS replace it immediately. If you fail to do so, the seat sling or seat back upholstery may sag or fail.
2. The upholstery on your chair is flame retardant. Laundering or allowing the upholstery to become wet repeatedly will reduce the flame retardant qualities of the fabric.
3. DO NOT “drop down” into your chair. By placing undue force on the upholstery, you will weaken the fabric and it may become worn sooner than it otherwise would. If you do “drop down” into your chair on a regular basis, inspect and replace the upholstery more often.
4. The upholstery on your chair will weaken with age and use. Regularly inspect your upholstery for fraying, thin spots, or stretching of the fabric at the rivet holes.

If you ignore these Warnings, you may fall, tip over or lose control of the wheelchair and seriously injure yourself or others or damage the wheelchair.

D. SEATING SYSTEMS

⚠ WARNING

TiLite does not sell any seating systems specifically designed for use with TiLite wheelchairs, nor does TiLite recommend any particular seating system. If your doctor or therapist recommends that you use a seating system with your TiLite chair, always consult with an authorized TiLite dealer to determine if the recommended seating system is compatible with your TiLite chair. In addition, the following warnings must be followed:

1. If you add a seating system to your TiLite chair, you will affect its center of balance. This may cause the chair to tip over. Therefore, NEVER install a new seating system on your own. Instead, have it installed by an authorized TiLite dealer who can assist you in making other necessary adjustments to ensure your center of balance is maintained as closely as possible to what you are used to.
2. As with other changes to the configuration of your chair that affect its center of balance, if you add a seating system to your TiLite chair, ALWAYS use anti-tips until you have fully learned to control your chair in its new configuration.
3. Keep in mind that adding a seating system also may inhibit the proper operation of a folding back wheelchair.

If you ignore these Warnings, you may fall, tip over or lose control of the wheelchair and seriously injure yourself or others or damage the wheelchair.

E. POSITIONING OR SEAT BELTS

⚠ WARNING

TiLite hook & loop, non-padded seat belts and Bodypoint® non-padded hip belts, both of which are optional equipment, are intended ONLY for use as a positioning aid for simple positioning needs, such as posterior pelvic tilt. These belts will not be sufficient for persons with more involved positioning needs. Only your health care advisor can determine the proper positioning products for your situation. If used improperly, positioning or seat belts can cause severe injury or even death. If your health care advisor has instructed you to use positioning or seat belts, make sure they instruct you on the proper usage of such belts, and such professional should supervise your use of such belts to ensure you can use them safely.

1. Belts must fit snugly in order to work properly. However, they must not be so snug they interfere with your breathing. Your health care advisor should be able to slide his or her open hand flat between the belt and your body.
2. Make sure you do not slide down in your chair while wearing a belt. If this should happen, you may suffer chest compression or be suffocated due to pressure from the belt.
3. Do not use a positioning or seat belt unless you are capable of removing the belts easily in an emergency. If you cannot do this, consult with your health care advisor for other options to help with your posture.
4. There are devices that help to keep you from sliding down in the seat of your wheelchair, such as a pelvic wedge. Consult with your health care advisor to find out if you need to use such a device in conjunction with positioning or seat belts to mitigate the risks described above.
5. NEVER use positioning or seat belts as a motor vehicle restraint. These types of belts are NOT intended to protect the wheelchair rider from the forces involved in a vehicle accident, and they may, in fact, cause you to be injured. TiLite recommends wheelchair users ALWAYS transfer to appropriate motor vehicle seating when traveling in a motor vehicle.

Note to Attendants/Assistants: NEVER use positioning or seat belts as a patient restraint (a restraint requires a doctor's order) or on a wheelchair user who is comatose or agitated.

If you ignore these Warnings, you may fall, tip over or lose control of the wheelchair and seriously injure yourself or others or damage the wheelchair.

F. ARMRESTS

⚠ WARNING

Armrests are optional equipment on TiLite wheelchairs. TiLite armrests are detachable and are not designed to support the weight of your wheelchair. Therefore, NEVER lift your chair by its armrests. If you do, they may detach, causing you to drop the chair, or you may break the armrests or cause them to become loose and break at a later

CHAPTER 1: WARNINGS

time unexpectedly. ALWAYS lift your chair by grasping the non-detachable parts of the main frame (not including the swing-away hangers or backrests).

If you ignore these Warnings, you may fall, tip over or lose control of the wheelchair and seriously injure yourself or others or damage the wheelchair.

G. FOOTRESTS/HANGERS

⚠WARNING

Certain footrests are standard equipment with TiLite wheelchairs. Other, more specialized footrests are optional equipment. The following rules apply to footrests:

1. ALWAYS allow for AT LEAST 2 inches of clearance between the ground and the lowest point on the underside of your footrests. If you set your footrests too LOW, they may “catch” on obstacles you can expect to find in normal use of your chair. If your footrests “catch,” the chair may stop and tip forward.
2. NEVER lift your wheelchair by grasping the footrests or the swing-away hangers. Footrests and swing-away hangers are detachable and are not designed to support the weight of your chair. If you do, the footrests or the swing-away hangers may detach, causing you to drop the chair, or you may break the footrests or the swing-away hangers or cause them to become loose and break at a later time unexpectedly.
3. READ and understand the warnings under “Transferring In and Out of Your Wheelchair” on pages 1-7 to 1-8 of this Manual. There is important information in that section regarding your footrests and transfers.

If you ignore these Warnings, you may fall, tip over or lose control of the wheelchair and seriously injure yourself or others or damage the wheelchair.

H. REAR WHEELS

⚠WARNING

Rear wheels are standard components on your wheelchair. The positioning of the rear wheels is a critical factor in locating the center of balance of your chair. Any change to your rear wheel position will change your center of balance. Therefore, use extreme caution when making any adjustment to the position of your rear wheels.

1. As you move the rear wheels and axles forward on your chair, you shift the center of balance FORWARD. This means it is easier for your chair to tip over backward.
2. As you move the rear wheels and axles backward on your chair, you shift the center of balance BACKWARD. This means your chair is less likely to tip-over backward. However, even if your rear wheels and axles are set as far back as possible, the chair can still tip-over backward.
3. ALWAYS consult with your health care provider to determine the best rear wheel/axle setup for you based on your weight and body type and your abilities to control the chair.
4. Once you and your health care provider have determined the best rear wheel/axle setup for you, NEVER change the setup UNLESS you are sure you are not at risk to tip over.
5. If you do change the rear wheel/axle position, you MUST adjust the positioning of the rear wheel locks to ensure they work properly to lock the rear wheels. When relocating the rear wheel locks, make sure the locking arm indents the tire by at least 3/16” when the wheel lock is in the “locked” position.

If you ignore these Warnings, you may fall, tip over or lose control of the wheelchair and seriously injure yourself or others or damage the wheelchair.

I. AXLES

⚠WARNING

Stainless quick-release axles are a standard TiLite wheelchair component. Other axle types are optional equipment. All TiLite axles are designed to make your rear wheels easy to remove quickly. However, if not used properly, they can be dangerous.

NEVER use your chair UNLESS you are sure that both rear axles are locked into place in the axle receiver. If an axle is not fully locked into place, the rear wheel may come off during use of the chair and cause you to fall. You can tell when the axle is locked into place because the quick-release button in the center of the axle will pop out fully. It is also

a good idea to pull on the wheel to double-check that the axle is securely locked as a final precaution.

If you ignore these Warnings, you may fall, tip over or lose control of the wheelchair and seriously injure yourself or others or damage the wheelchair.

J. PNEUMATIC TIRES

⚠WARNING

Pneumatic rear tires are standard components on TiLite wheelchairs. Pneumatic front tires are optional equipment on some TiLite wheelchairs.

With pneumatic tires, it is important to maintain the proper inflation. Maintaining the proper inflation will extend the life of your tires and will reduce the rolling resistance of your chair, making it easier to use.

1. Check your tires WEEKLY for proper inflation. The correct inflation level is imprinted on the tire sidewall.
2. DO NOT use your chair if any of the pneumatic tires are under-inflated or over-inflated.
3. If any tire is under-inflated, the chair may tend to veer to one side, which could cause you to lose control of the chair.
4. If a rear tire is under-inflated, the wheel lock for that wheel may not work properly and may slip, thereby allowing the wheel to turn unexpectedly.
5. An over-inflated tire may burst, thereby causing a loss of control of the chair.
6. ALWAYS have pneumatic tire inner tubes replaced by an authorized TiLite dealer.

If you ignore these Warnings, you may fall, tip over or lose control of the wheelchair and seriously injure yourself or others or damage the wheelchair.

K. REAR WHEEL LOCKS

⚠WARNING

Standard rear wheel locks are available on all TiLite wheelchairs as a no-charge option. Scissor locks and uni-locks are optional equipment. TiLite wheel locks are NOT designed to slow or stop a moving wheelchair - they are NOT brakes. Wheel locks are ONLY designed to keep the rear wheels from rolling when your chair is at a complete stop.

1. NEVER attempt to “brake” by using rear wheel locks to try to slow or stop your chair when it is moving. If you do so, you will lose control of the chair and may fall.
2. ALWAYS make sure the locking arm of your wheel lock embeds into the tire at least 3/16” when in the locked position. If the wheel lock does not properly embed in the tire, the wheel lock may not work and the chair may roll unexpectedly.
3. ALWAYS maintain proper tire pressure. If a rear tire is under-inflated, the wheel lock for that wheel may not work properly and may slip, thereby allowing the wheel to turn unexpectedly.
4. When you transfer to or from your chair, ALWAYS set both rear wheel locks to prevent the rear wheels from rolling.

If you ignore these Warnings, you may fall, tip over or lose control of the wheelchair and seriously injure yourself or others or damage the wheelchair.

L. CASTER PIN LOCKS

⚠WARNING

Caster pin locks are an optional accessory for TiLite wheelchairs. Caster pin locks are not designed to slow or stop a moving wheelchair – they do not prevent the casters from rotating on the axis of the axle. Caster pin locks are ONLY designed to keep the front casters from rotating on the axis of the stem bolt when your chair is at a complete stop. In other words, properly engaged caster pin locks will not stop the chair from rolling, but will stop it from turning.

1. ALWAYS make sure the locking pin on your caster pin locks fully engages with the front casters. If the caster pin lock does not properly engage, the caster pin lock may not work properly and the front casters may rotate causing the chair to turn unexpectedly.

CHAPTER 1: WARNINGS

2. When you transfer to or from your chair, ALWAYS set both rear wheel locks and both caster pin locks to prevent the rear wheels from rolling and front casters from rotating.

If you ignore these Warnings, you may fall, tip over or lose control of the wheelchair and seriously injure yourself or others or damage the wheelchair.

M. PUSH HANDLES

⚠WARNING

Push handles are optional equipment on TiLite wheelchairs. Push handles provide secure points for an attendant or assistant to hold the rear of the chair to prevent a fall or tip-over. If you have an attendant or assistant, you should have push handles installed on your chair by TiLite. TiLite offers push handles that are integral to the back canes and bolt-on push handles. TiLite recommends that you do NOT use non-TiLite bolt-on push handles because they will damage the backrest of your TiLite chair. Your attendant or assistant should regularly check the push handle grips to make sure they fit securely and will not rotate or slip off. Push handles should NEVER be used to lift the chair or pull the chair, especially when it is occupied, as they may detach. ALWAYS lift or pull the chair by grasping a non-detachable part of the main frame (not the backrest, armrest or footrest).

If you ignore these Warnings, you may fall, tip over or lose control of the wheelchair and seriously injure yourself or others or damage the wheelchair.

N. FASTENERS

⚠WARNING

TiLite uses only high-strength, high-quality fasteners (nuts, bolts, screws and clamps) on its wheelchairs. If you replace any of these fasteners with improper or inferior fasteners, you may damage your chair or may cause it to fail unexpectedly.

1. ALWAYS use fasteners obtained from an authorized TiLite dealer.
2. REGULARLY inspect all fasteners to make sure they have not become loose. If any become loose, tighten them immediately.
3. NEVER over- or under-tighten the fasteners on your chair. Over-tightened or under-tightened fasteners may damage your chair or fail unexpectedly.

If you ignore these Warnings, you may fall, tip over or lose control of the wheelchair and seriously injure yourself or others or damage the wheelchair.

O. POWER DRIVE

⚠WARNING

Certain manufacturers offer manual wheelchair power drive add-on products. TiLite has approved only a limited number of these products for use with TiLite wheelchairs. For more information about power add-ons approved by TiLite, contact TiLite Customer Service.

If you intend to install an approved power drive system on your TiLite chair, this must be taken into account when your chair is ordered so TiLite can manufacture your chair with a power-adaptable frame.

If you have not purchased your TiLite chair with a power adaptable frame, do not install a power drive on your TiLite chair. If you install a power drive add-on system to your TiLite chair and your chair does not have a power adaptable frame, you may damage your chair and you will void your warranty.

In addition, power drive systems are heavy and will affect the center of balance of your chair. Any change to the center of balance of your chair could cause you to lose control or fall or tip-over.

If you ignore these Warnings, you may fall, tip over or lose control of the wheelchair and seriously injure yourself or others or damage the wheelchair.

P. UNAUTHORIZED PARTS AND ACCESSORIES

NEVER use parts, accessories or adapters other than those authorized by TiLite. If you have any doubt about the compatibility of a particular part, accessory or adapter, consult with an authorized TiLite dealer or contact TiLite Customer Service.

If you ignore these Warnings, you may fall, tip over or lose control of the wheelchair and seriously injure yourself or others or damage the wheelchair.

CHAPTER 2: SAFETY INSPECTION, MAINTENANCE & TROUBLESHOOTING

Introduction

Your TiLite wheelchair is designed, engineered and built to provide you with years of exceptional performance. However, proper maintenance and regular safety inspections are essential in order to make sure your wheelchair is operating properly, safely and at maximum efficiency. In addition, proper maintenance and regular safety inspections will extend the life of your TiLite wheelchair.

Safety Inspections and Maintenance

⚠ WARNING

If you fail to inspect and maintain your wheelchair as directed in this Manual, you will be at risk for health complications or you may fall, tip over or lose control of your wheelchair and seriously injure yourself or others or damage the wheelchair.

⚠ WARNING

After making ANY adjustments or repairs to your wheelchair and after any servicing of your wheelchair, ALWAYS make sure all attachment hardware is tightened securely BEFORE using the chair. *If you ignore this Warning, you may fall, tip over or lose control of your wheelchair and seriously injure yourself or others or damage the wheelchair.*

1. You MUST inspect and maintain your TiLite wheelchair strictly in accordance with the following chart.
2. If your inspection uncovers any problem, make sure to service or repair the problem BEFORE using the wheelchair.
3. If your inspection reveals any loose, worn, bent or damaged parts, you MUST tighten, repair or replace them before using your TiLite wheelchair.
4. Clean your wheelchair ONLY in accordance with the instructions under “Cleaning” on page 2-3.
5. Annually, or more often if necessary, you MUST have your wheelchair serviced and thoroughly inspected by a qualified TiLite dealer.
6. In addition to the maintenance and safety inspections indicated in the chart below, ALWAYS make sure that all nuts and bolts are tight before riding in your wheelchair.

Inspection Item	Initially	Weekly	3 Months
General <ul style="list-style-type: none"> • Make sure chair rolls straight (does not drag or pull to one side) Inspect for loose/missing/broken/worn/damaged hardware 	√ √	√ √	
Rear Wheels <ul style="list-style-type: none"> • Inspect for cracked, bent or broken spokes • Make sure all spokes are uniformly tight • Inspect hubs and rims for cracks and wear • Inspect for “trueness” (excessive side movement when wheel lifted and spun indicates lack of “trueness”) 	√ √ √ √	√ √	√ √
Quick-Release/Quad-Release Axles <ul style="list-style-type: none"> • Make sure axles are free of dirt and lint • Wipe axle with cloth using either a “dry” silicone spray or a “dry” Teflon® -based lubricant • Make sure that axles lock properly in axle sleeve 	√ √	 √ ¹	√ √

¹You MUST make sure that axle locks properly in the axle sleeve every time you remove and reinstall a rear wheel, and you should verify this at least weekly.

CHAPTER 2: SAFETY INSPECTION, MAINTENANCE & TROUBLESHOOTING

Inspection Item	Initially	Weekly	3 Months
Rear Tires <ul style="list-style-type: none"> • Check for proper inflation as per sidewall of pneumatic tire • Inspect for cracks, wear and flat spots 	√ √	√ √	
Camber Tube/Axle Sleeves <ul style="list-style-type: none"> • Make sure camber plug clamps are securely tightened • Make sure camber plugs are secure in camber plug clamps and axle sleeves are secure in camber plugs 	√ √	√ √	
Handrims <ul style="list-style-type: none"> • Inspect for signs of rough edges or peeling • Make sure handrims are securely attached to rim 	√ √		√ √
Wheel Locks <ul style="list-style-type: none"> • Make sure wheel locks embed proper distance into tire and prevents chair from moving when engaged • Make sure wheel locks do not interfere with tire when disengaged • Make sure pivot points are free of wear and looseness 	√ √ √	√ √ √	
Seat Sling and Back Upholstery <ul style="list-style-type: none"> • Inspect for rips or sagging • Inspect fastening flaps to ensure they are securely attached • Inspect while seated to ensure sling supports your weight and does not touch crosstubes 	√ √ √	√ √	√
Casters/Forks <ul style="list-style-type: none"> • Inspect wheels and tires for cracks and wear • Inspect wheel/fork assembly for proper tension by spinning caster (caster should come to a gradual stop); if caster wobbles, tighten the axle • Inspect wheel/fork assembly/stem bolt to ensure that stem bolt is secure (wheel/fork assembly should not have excessive play relative to the stem bolt but should rotate freely); if necessary, tighten stem bolt • Ensure that wheel bearings are clean and free from moisture • If pneumatic, check for proper inflation as per the sidewall 	√ √ √ √	√ √ √	√ √
Armrests <ul style="list-style-type: none"> • Inspect to ensure that all hardware is securely attached 	√	√	
Footrests/Hangers <ul style="list-style-type: none"> • Inspect to ensure that all hardware is securely attached 	√	√	
Anti-tips <ul style="list-style-type: none"> • Inspect anti-tip wheel for cracks and wear • Inspect to ensure that anti-tip receptacle is securely attached 	√ √	√	√
Frame <ul style="list-style-type: none"> • Inspect for cracks 	√		√

CHAPTER 2: SAFETY INSPECTION, MAINTENANCE & TROUBLESHOOTING

Cleaning

Clean your chair regularly. Cleaning often will reveal loose or worn parts and enhance the smooth operation of your chair.

Cleaning the Frame

1. If your titanium frame came with a “Satin” finish, use a soft cloth to clean the finish. If necessary, moisten the cloth with glass cleaner. If the “Satin” finish of your chair becomes scratched, you can buff out the scratch using the grey, ultrafine Scotch Brite™ pad that was shipped with your chair. Moisten the pad with water and rub it over the scratch in a circular motion. After buffing, wipe off the buffed area using a soft cloth moistened with glass cleaner or wood furniture polish.

Note: Do NOT use a Scotch Brite™ pad on the logo, and NEVER use steel wool to clean your frame.

Note: Over-the-counter Scotch Brite™ pads will not work as effectively as the grey, ultrafine Scotch Brite™ pad that shipped with your chair. If you have misplaced the grey, ultrafine Scotch Brite™ pad, contact TiLite Customer Service to purchase a replacement.

2. If your titanium chair came with a “Polished” finish, use a soft cloth to clean the finish. If necessary, moisten the cloth with glass cleaner.

Note: NEVER use Scotch Brite™ pads or steel wool on a polished frame.

3. If your chair has a painted frame, use a soft clean cloth with soap and water to clean the frame. Immediately dry all components and parts that become wet.

Note: Do NOT use Scotch Brite™ pads, steel wool, abrasive cleaners or petroleum-derived products to clean a painted aluminum or titanium frame.

Cleaning the Upholstery

1. Regularly hand-wash the seat sling and back upholstery using water and a mild detergent. Always allow the upholstery to air dry before riding in the chair.
2. NEVER machine wash the upholstery, and NEVER machine dry the upholstery.
3. When washing the upholstery, carefully check for sagging, rips or tears. If you find any rips or tears, you MUST order new upholstery.
4. After washing the seat sling, always check the tension while seated in the chair to ensure the sling does not touch the crosstube beneath the seat sling.

Axles and Moving Parts

Clean axles and other moving parts weekly with a slightly damp, but not wet, cloth. Try to wipe away any lint, dust or dirt on these parts that could interfere with their smooth operation. DO NOT use WD-40®, 3-in-1 oil®, or other penetrating lubricants on quick-release or quad-release axles. Instead, as indicated in the chart under “Safety Inspections and Maintenance,” ALWAYS use either a “dry” Teflon®-based lubricant or a “dry” silicone spray as a lubricant.

Storage

1. Always store your chair in a clean, dry location. Excessive dirt can cause moving parts to become damaged or fail. Moisture can rust or corrode the non-titanium components of your chair.
2. Always fully inspect your chair after it has been stored for any period before riding in it. See the chart under “Safety Inspections and Maintenance” on pages 2-1 to 2-3.
3. If you store your chair for more than three (3) months, have your chair inspected by an authorized TiLite supplier.

CHAPTER 2: SAFETY INSPECTION, MAINTENANCE & TROUBLESHOOTING

Troubleshooting

Your TiLite wheelchair is a precision-engineered product. To ensure your chair continues to operate at peak performance, you will need to make minor adjustments from time to time — especially if you alter the original factory settings. The chart below provides advice on solving some of the more common “adjustment” issues you may experience. If the solutions below do not solve your problem or if you experience a problem not addressed below, please contact an authorized TiLite supplier or TiLite Customer Service. Please note, if more than one solution in the chart below applies to your particular adjustment issue, always try one solution at a time until the problem is solved.

Chair Veers Right or Left	Caster Flutter	Looseness in Chair	Squeaks and Rattles	Sluggish Turning or Performance	Floating Caster	Solution
√	√			√	√	If you have pneumatic front and/or rear tires, make sure that the tires are properly and equally inflated
	√	√	√	√		Make sure that all nuts and bolts are securely tightened
		√	√			Make sure that all spokes and nipples are uniformly tight on all spoked wheels
√	√			√	√	Make sure that the caster barrels and mounts are properly adjusted
	√	√	√	√		Make sure that rear wheels are equally spaced away from the seat frame
√				√		Adjust the toe-in/toe-out of the rear wheels
					√	Make sure that both sides of the footrest are set at an equal distance from the floor

⚠ WARNING

Check all clamps, screws, nuts and bolts that secure the footrest to the wheelchair frame to make sure they are securely tightened before using the wheelchair. *If you ignore this Warning, the footrests could move unexpectedly while you are using the chair, causing you to fall, tip over or lose control of the wheelchair and seriously injure yourself or others or damage the wheelchair.*

⚠ WARNING

A titanium open loop footrest is available as an option. A footrest cover is recommended for wheelchair users that have leg spasticity or whose feet have a possibility of falling through an open loop footrest. *If you ignore this Warning, you could fall, tip over or lose control of the wheelchair and seriously injure yourself or others or damage the wheelchair.*

⚠ WARNING

A calf strap is offered as an option with each wheelchair to prevent your feet from slipping backwards off of the footrest. TiLite recommends that you purchase our calf strap with your wheelchair. Always make sure the calf strap is secure when using the wheelchair. *If you ignore this Warning, you could fall, tip over or lose control of the wheelchair and seriously injure yourself or others or damage the wheelchair.*

⚠ WARNING

Whenever you adjust the angle or height of your footrest, or you replace your footrest, always allow at least 2" of ground clearance to permit you to maneuver over objects. *If you ignore this Warning, you could fall, tip over or lose control of the wheelchair and seriously injure yourself or others or damage the wheelchair.*

Safe Tread

If you ordered your wheelchair with either the Titanium Footrest with Flat ABS Cover or the Titanium Open Loop Footrest, enclosed with your chair are two 4" squares of self-adhesive Safe Tread. Safe Tread provides a more slip-resistant surface than the footrest of your chair. Use of the Safe Tread is optional, but TiLite recommends you use it in order to reduce the likelihood of your feet slipping off the footrest during use of your chair. If you choose to apply the Safe Tread to your footrest, follow the following instructions:

1. See Figure 3-1 for the suggested location of the Safe Tread.
2. Without removing the adhesive backing strip, position the Safe Tread on the footrest and, if necessary, use a pen or pencil to draw any edges that need to be trimmed.
3. Carefully cut the Safe Tread to size using scissors, knife or razor blade.
4. Thoroughly clean and dry the footrest.
5. Peel the adhesive strip backing from the Safe Tread and press firmly to the surface of the footrest, starting from the center and working toward the edges of the Safe Tread, making certain the edges are fully adhered.

Figure 3-1
Footrest with Safe Tread

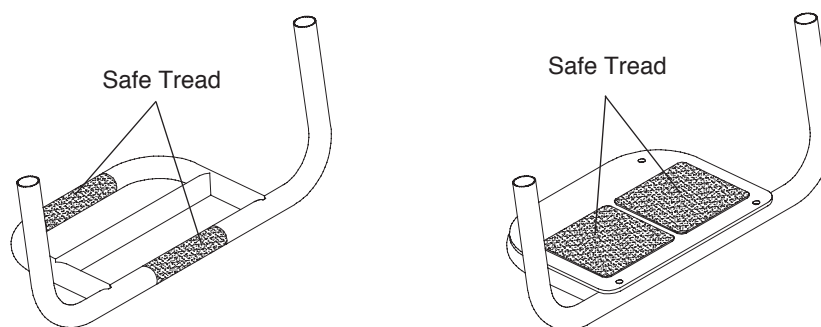

CHAPTER 3: FOOTRESTS

Titanium Footrest with Flat ABS Cover

Adjusting the Height/Replacing

(TR and YR Series 2)

Tools Needed:

- 1/8" Allen Wrench
- Ruler

1. Loosen, but do not remove, the two Allen screws that engage the T-Nuts to the clamps that secure the footrest to the frame. See Figure 3-2. Loosen the screws just enough to permit the footrest tubes to slide up and down within the covers. Do not detach the footrest clamps from the frame.
2. If replacing the footrest, remove the old footrest and insert the new footrest tubes through the covers and into the frame.

Figure 3-2
Footrest Replacement

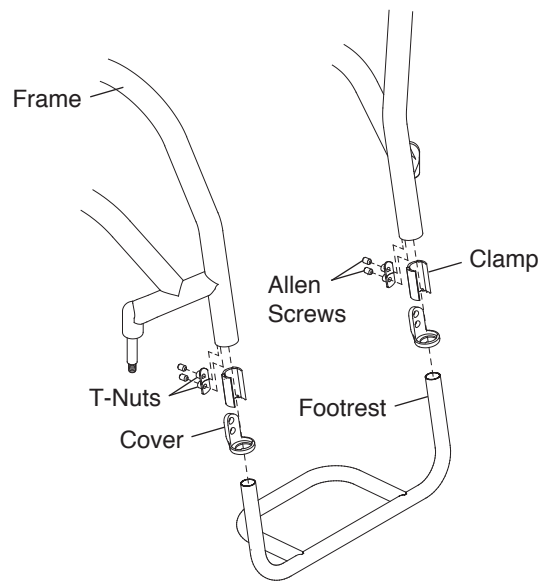

3. Place the end of a ruler on the floor and hold it vertically against the corner of the footrest. See Figure 3-3. Adjust the footrest to the desired height (not less than 2" of ground clearance) and tighten the Allen screws in the left and right clamp so the left footrest cannot change.

Note: When adjusting the height of the footrest, make sure that at least 1-3/4" of the extension tube remains up inside the frame tube. See Figure 3-4.

4. Repeat the procedure from Step 2 above on the right side of the footrest.
5. When both sides are set at an equal distance from the floor, fully tighten the two Allen screws into the two T-Nuts securing the footrest to the frame, making sure the covers remain securely butted up against the end of the frame tube.

Adjusting the Height/Replacing

(TR Series 3)

See "Angle Adjustable Footrest - Adjusting the Height/Replacing (TR Series 3)" on page 3-4.

Figure 3-3
Footrest Height Adjustment

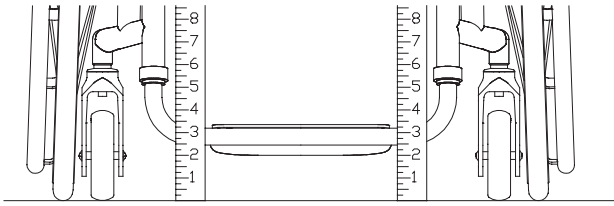
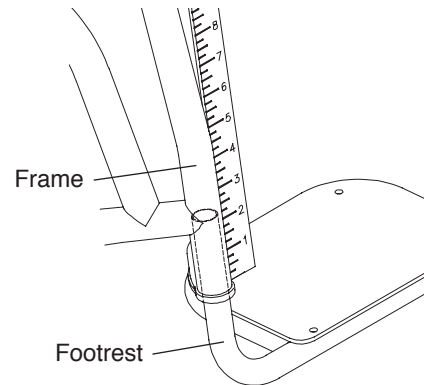

Figure 3-4
Footrest Height Adjustment



⚠ WARNING

The threads on the Allen screws that secure the T-Nuts within the footrest clamp assembly are treated with Vibra-TITE® VC-3, a locking and sealing coating. You should be able to adjust the height of the footrest approximately four times without reapplying the coating. TiLite requires that you reapply Vibra-TITE® VC-3 after every fourth adjustment. *If you ignore this Warning, your footrest could become loose or fall off and you could fall, tip over or lose control of the wheelchair and seriously injure yourself or others or damage the wheelchair.*

Titanium Open Loop Footrest

The Titanium Open Loop Footrest (see Figure 3-5) can be replaced or the height adjusted by using the tools and following the procedures under “Titanium Footrest with Flat ABS Cover - Adjusting the Height/Replacing (TR and YR Series 2)” on page 3-2 or “Titanium Footrest with Flat ABS Cover - Adjusting the Height/Replacing (TR Series 3)” on page 3-2.

Figure 3-5
Titanium Open Loop Footrest

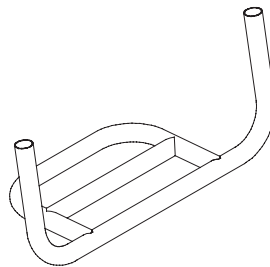

Angle Adjustable Footrest

Adjusting the Angle

Tools needed:

- 5/32" Allen Wrench

1. Loosen, but do not remove, the two Allen screws that secure the footplate to the clamp. See Figure 3-6.
2. Adjust the footrest to desired angle.
3. Tighten the Allen screws, making sure the screws and the locknuts are secure and will not permit the footplate to move up or down under weight.

CHAPTER 3: FOOTRESTS

Figure 3-6
Adjusting the Angle

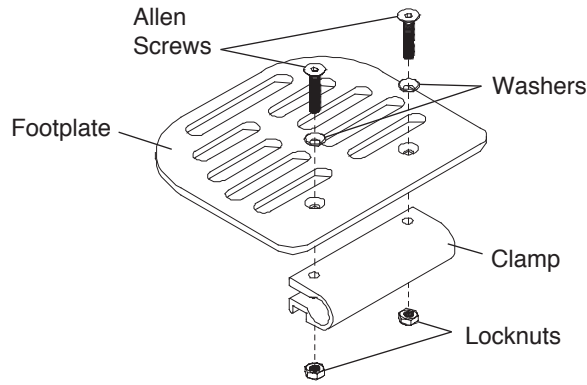

Adjusting the Height/Replacing (TR and YR Series 2)

See “Titanium Footrest with Flat ABS Cover - Adjusting the Height/Replacing (TR and YR Series 2)” on page 3-2.

Adjusting the Height/Replacing (TR Series 3)

Tools needed:

- 3/16” Allen Wrench
- Ruler

1. Loosen, but do not remove, the Allen screws in the two binder clamps that secure the footrest to the frame. See Figure 3-7. If replacing the footrest, loosen the Allen screws sufficiently to permit you to completely remove the old footrest and make sure to leave the plastic footrest insert sleeve inside the frame tube. If adjusting the height, loosen the Allen screws sufficiently to permit the footrest to move up and down freely within the binder clamps.
2. If replacing the footrest, remove the old footrest and install the new footrest into the frame.
3. Place the end of a ruler on the floor and hold it vertically against the left corner of the footrest. Adjust the left side of the footrest (or the new footrest) to the desired height (not less than 2” of ground clearance) and loosely tighten the Allen screw in the left binder clamp so the left side of the footrest cannot change. See Figure 3-3.
4. Repeat the procedure from Step 3 above on the right side of the footrest (or the new footrest).
5. When both sides are set at an equal distance from the floor, make sure all four (4) wheels are in contact with the floor and then fully tighten the two Allen screws in the binder clamps that secure the footrest to the wheelchair frame.

Figure 3-7
Angle Adjustable Footrest

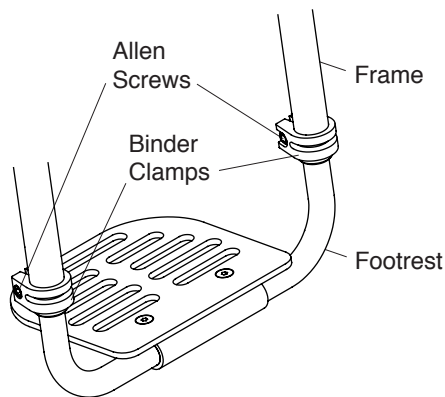

Angle Adjustable High Mount Footrest

Adjusting the Angle

Tools needed:

- 5/32" Allen Wrench (no extension tubes)
- 3/16" Allen Wrench (extension tubes only)

1. Loosen, but do not remove, the Allen screws. See Figure 3-8. If your footrest has extension tubes (see Figure 3-9), you will have 3/16" Allen screws in place of locknuts and you will only need to loosen these latter Allen screws to adjust the angle.
2. Adjust the footrest to the desired angle.
3. Tighten the Allen screws and locknuts (or 3/16" Allen screws), making sure the screws and the locknuts (or 3/16" Allen screws) are secure and will not permit the footplate to rotate up or down under your weight.

Figure 3-8
Angle Adjustable High Mount Footrest

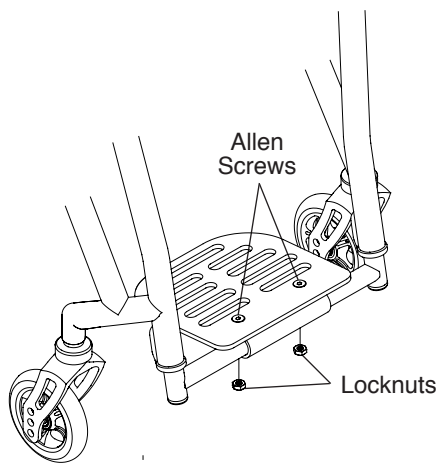
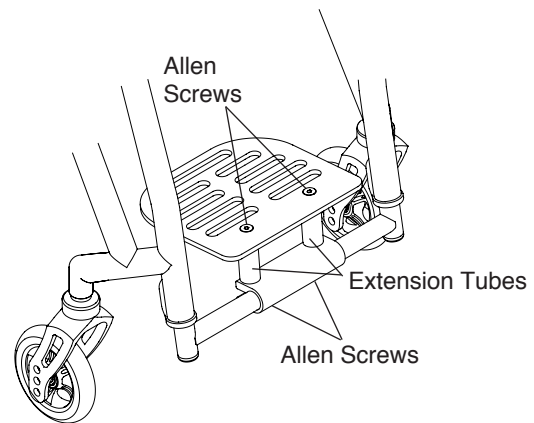

Figure 3-9
Angle Adjustable High Mount Footrest with Extension Tubes



Adjusting the Height/Replacing

The Angle Adjustable High Mount Footrest can be replaced or the height adjusted by using the tools and following the procedures under "Titanium Footrest with Flat ABS Cover - Adjusting the Height/Replacing (TR and YR Series 2)" on page 3-2 or "Angle Adjustable Footrest - Adjusting the Height/Replacing (TR Series 3)" on page 3-4.

Flip-Back Footrest

The Flip-Back Footrest can be flipped upward and backward to position the footplate out of the way for purposes of transferring into and out of the wheelchair. See Figures 3-10 and 3-11.

Figure 3-10
Flip Back Footrest

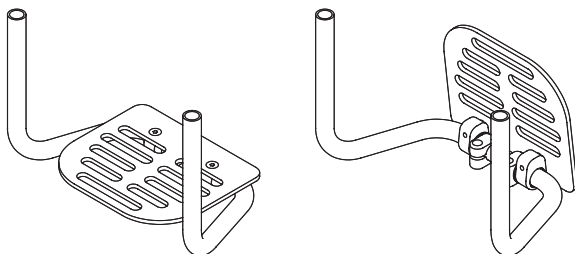
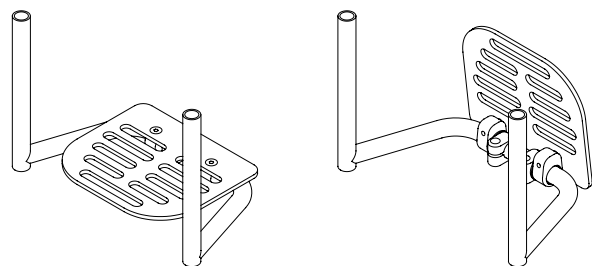

Figure 3-11
High Mount Flip Back Footrest



CHAPTER 3: FOOTRESTS

Adjusting the Angle

Tools needed:

- 3/16" Allen Wrench
1. Loosen, but do not remove, the two Allen screws that secure the stop clamps to the footrest extension tube. See Figure 3-12.
 2. Adjust the footrest to the desired angle.
 3. Tighten the Allen screws. Make sure the screws are secure and will not permit the footplate to rotate up or down under weight.

Adjusting the Height/Replacing

You can adjust the height of, or replace, the flip back footrest by using the tools and following the procedures for adjusting the height of, or replacing a footrest as set forth under "Titanium Footrest with Flat ABS Cover - Adjusting the Height/Replacing (TR and YR Series 2)" on page 3-2 or "Angle Adjustable Footrest - Adjusting the Height/Replacing (TR Series 3)" on page 3-4.

Buckle Adjustable Calf Straps

Buckle Adjustable Calf Straps are shown in Figure 3-13. Install the calf strap as shown in Figure 3-13.

Adjustable Calf Strap/Padded Adjustable Calf Strap

The Adjustable Calf Strap and Padded Adjustable Calf Straps are shown in Figure 3-14. Install the calf straps as shown in Figure 3-14.

Figure 3-12
Adjusting the Angle

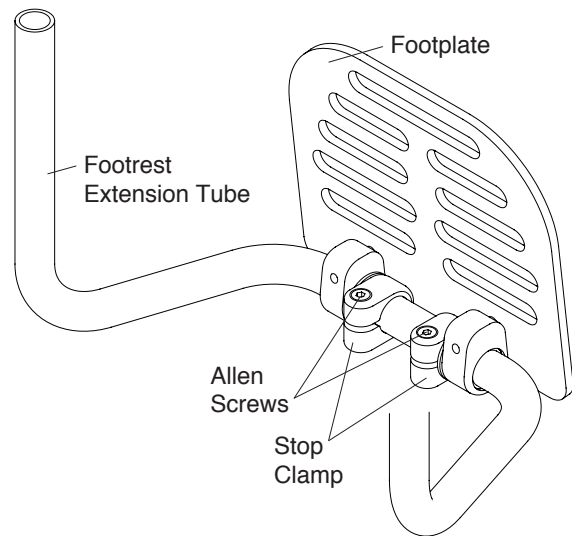

Figure 3-13
Buckle Adjustable Calf Strap

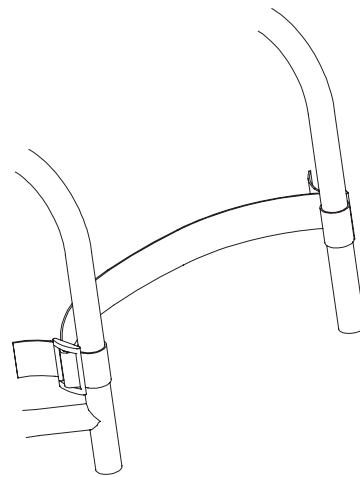
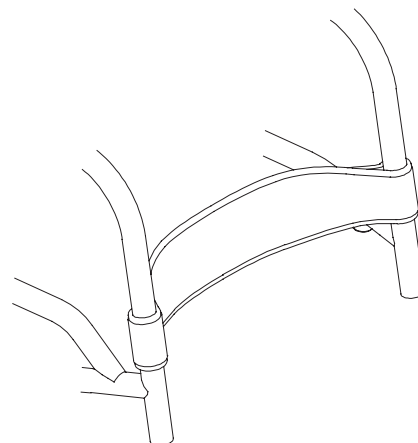

Figure 3-14
Padded Adjustable Calf Strap



CHAPTER 4: BACKRESTS AND PUSH HANDLES

Folding Adjustable Height & Angle Backrest (Titanium or Aluminum)

Note: The Aluminum Adjustable Height and Angle Backrest without Integrated Push Handles is standard on the TR and YR. The Titanium Adjustable Height and Angle Backrest is available as an option. Integrated Push Handles are available as an option with either the titanium or aluminum backrest. The instructions in this section apply to all of these variations.

⚠ WARNING

Before using your wheelchair, make sure the Folding Adjustable Height & Angle Backrest is locked securely in place in the upright position and all mounting hardware is securely tightened. *If you ignore this Warning, you may fall, tip over or lose control of the wheelchair and seriously injure yourself or others or damage the wheelchair.*

Folding the Backrest

1. Grasp the TiShaft Release Bar and pull up. See Figures 4-1 and 4-2.
2. Push the backrest forward toward the front of the chair.

Note: If you have a Lock-Down Backrest, make sure the backrest is locked securely in the folded position.

Unfolding the Backrest

1. Lift up on the backrest and pull towards the rear of the chair.
2. Make sure backrest locks securely into place.

Unfolding the Lock-Down Backrest

1. Push up the TiShaft Release Bar and pull the backrest towards the rear of the chair.
2. Make sure the backrest locks securely into place.

Figure 4-1
TR/YR Series 2 Folding Adjustable Backrest
with TiShaft Release Bar

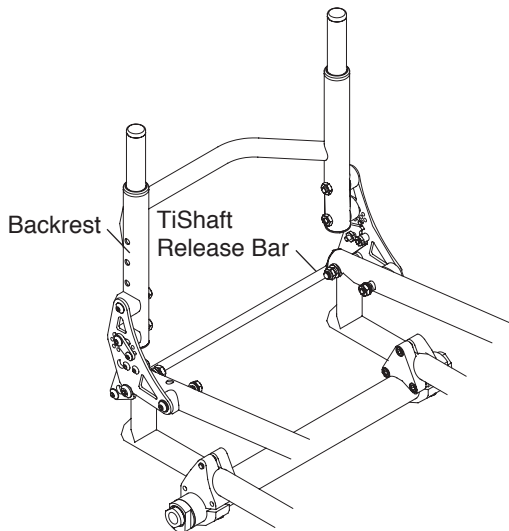
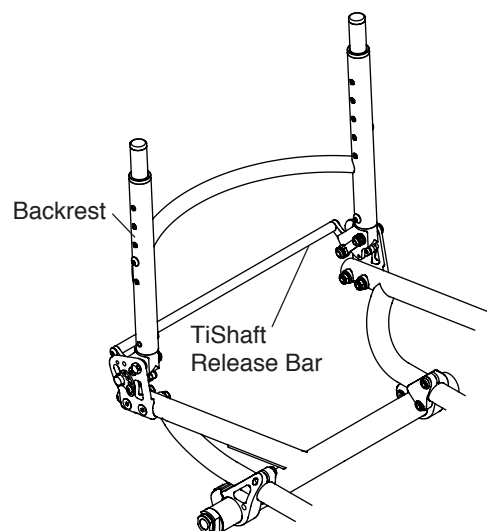

Figure 4-2
TR Series 3 Folding Adjustable Backrest (Titanium)
with TiShaft Release Bar



Adjusting the Backrest Lock Bracket (TR and YR Series 2)

Tools Needed:

- 3/16" Allen Wrench
- 1/2" Open End Wrench

CHAPTER 4: BACKRESTS AND PUSH HANDLES

If the backrest will not lock in the unfolded (upright) position, follow these procedures:

1. Fold the backrest down over the seat.
2. Loosen, but do not remove, the latch screw. See Figure 4-3.
3. Rotate the latch spacer.
4. Securely tighten the latch screw.
5. If the backrest still will not lock securely in the unfolded position, repeat the procedure on the opposite side of the chair.

Note: Do not over tighten the latch screw or you may damage the latch spacer.

Figure 4-3
Adjusting the Backrest Lock Bracket

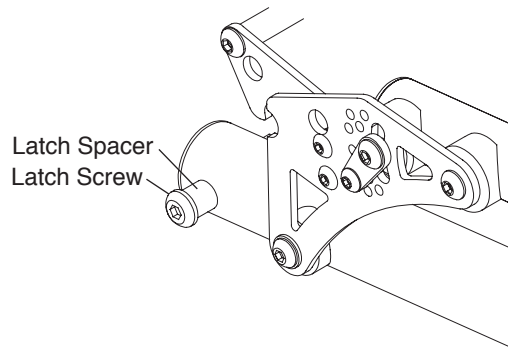

Adjusting if there is “Play” in the Backrest or Backrest Bracket (TR and YR Series 2)

Tools Needed:

- 7/16” Open End Wrench
- 5/32” Allen Wrench

If the backrest or backrest bracket becomes loose or there is “play” in the folding backrest assembly, follow these procedures:

1. On each side of the chair, tighten both Allen screws and the pivot screw shown in Figure 4-4.
2. Repeat this procedure until there is no “play” in the folding backrest assembly.
3. Do not over tighten the pivot screw or the backrest will not fold/unfold.

Note: If the above procedure does not completely eliminate the “play” in the backrest, tighten the latch screw. Do not over tighten the latch screw or you may damage the latch spacer. See Figure 4-4.

Figure 4-4
Adjusting the Backrest Bracket

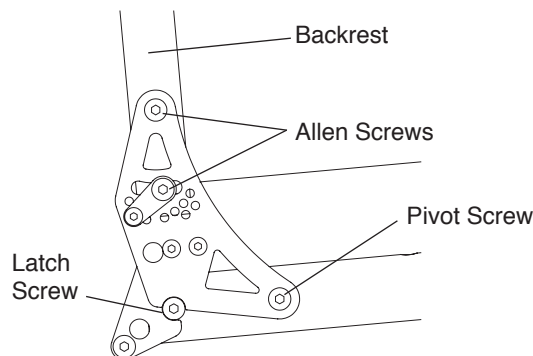

CHAPTER 4: BACKRESTS AND PUSH HANDLES

Adjusting the Backrest Mount

(TR Series 3)

Tools Needed:

- Two 7/16" Open End Wrenches

If your backrest is difficult to fold and unfold or is too loose, follow these procedures:

1. Using an Open End wrench, hold the pivot bolt in place and slightly loosen or tighten the nylock nut with the second Open End wrench. See Figure 4-5.
2. Repeat the procedure on each side of the chair until the desired tightness is achieved.

Figure 4-5
Adjusting the Backrest Mount

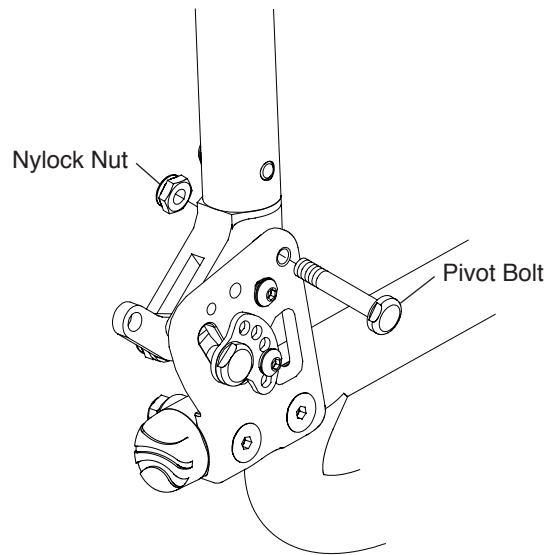

Changing the Backrest Angle

(TR and YR Series 2)

Tools Needed:

- 7/16" Open End Wrench
- 5/32" Allen Wrench
- 1/8" Allen Wrench

1. Lock the backrest in the unfolded position.
2. On both sides of the chair, loosen, but do not remove, the two Allen screws that attach the backrest to the bracket. See Figure 4-6.
3. On both sides of the chair, completely remove the link screw.
4. Keeping the bracket locked in the unfolded position, tilt the backrest forward or backward to the desired angle.
5. On one side of the chair, line up the hole in the link with the closest available threaded hole in the bracket. It may be necessary to make a minor adjustment to the backrest angle in order to properly align the hole in the link with an available threaded hole in the bracket. Once aligned, reinsert and fully tighten the link screw removed in Step 3 to securely attach the link to the backrest assembly.
6. On the opposite side of the chair, attach the link to the bracket using the corresponding threaded hole in the bracket using the link screw removed in Step 3. Securely tighten link screw.
7. On both sides of the chair, securely tighten the Allen screws that were loosened in Step 2.

CHAPTER 4: BACKRESTS AND PUSH HANDLES

Figure 4-6
Adjusting the Backrest Angle

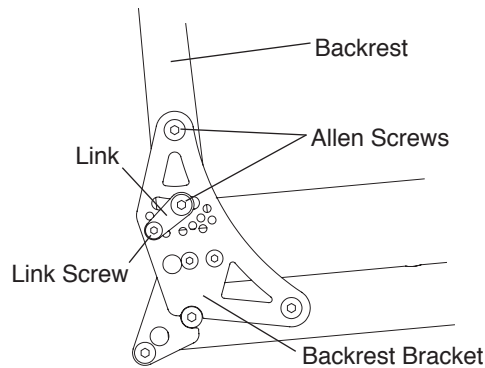

Changing the Backrest Angle (TR Series 3)

Tools Needed:

- Two 1/2" Open End Wrenches
- 1/8" Allen Wrench

1. On each side of the chair, using the Allen wrench, remove the Button Head Cap screw and lock washer. See Figure 4-7.
2. On each side of the chair, using the Open End wrenches, loosen but do not remove the stop bolt and nylock nut.
3. Adjust the backrest to the desired angle. On one side of the chair, while holding the backrest in place, align one of the five holes in the backrest cam with one of the three holes in the backrest mount. Place the Button Head Cap screw through the lock washer, the backrest cam and into the backrest mount. Securely tighten.
4. Securely tighten the stop bolt and nylock nut.
5. Repeat Steps 3 and 4 on the other side of the chair.

Figure 4-7
Changing the Backrest Angle

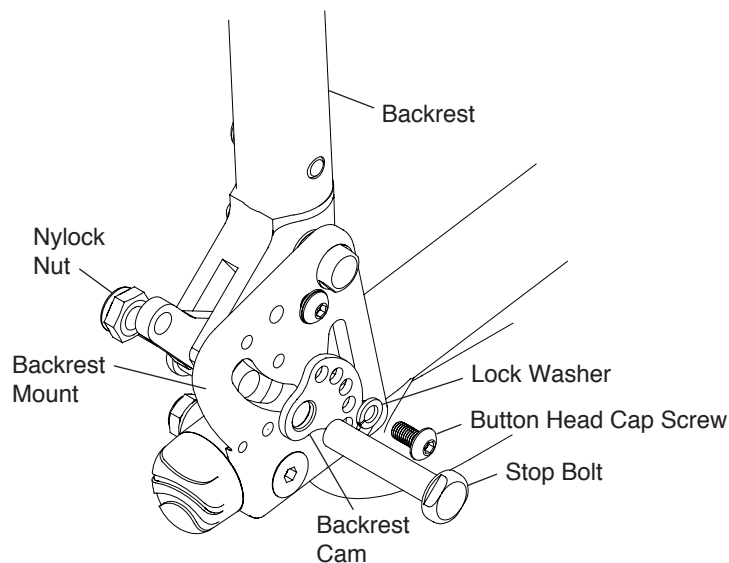

CHAPTER 4: BACKRESTS AND PUSH HANDLES

Adjusting the Backrest Height

(TR and YR Series 2)

Tools Needed:

- 5/32" Allen Wrench

Note: In order to adjust the backrest height, it is helpful to remove the backrest upholstery. Therefore, make a note of the tautness of the backrest upholstery before removing it so you can reinstall it to approximately the same degree of tautness.

1. Remove the backrest pad. See "Velcro®-Style Adjustable Back Upholstery" or "Tension Adjustable by Straps Back Upholstery" on pages 7-1 to 7-3.
2. On both sides of the chair, remove the Allen screw that secures the backrest post inside the backrest. See Figure 4-8.
3. Reposition both backrest posts to the desired height inside the backrest, making sure to align the holes in the backrest posts with the holes in the backrest.
4. Make sure both backrest posts are at the same height in the backrest and reinsert and securely tighten the two Allen screws.
5. Reinstall the backrest pad and adjust the upholstery to the desired tautness. See "Velcro®-Style Adjustable Back Upholstery" or "Tension Adjustable by Straps Back Upholstery" on pages 7-1 to 7-3.

Figure 4-8
Adjusting the Backrest Height

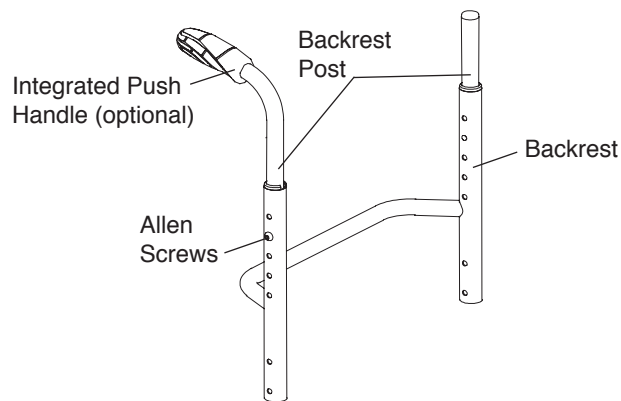

⚠ WARNING

The threads on the Allen screws that secure the backrest posts to the backrest have been treated with a Vibra-TITE® VC-3, a locking and sealing coating, to reduce the possibility that they will become loose. You should be able to adjust the backrest height approximately four times without reapplying thread lock to these screws. TiLite requires that you reapply Vibra-TITE® VC-3 after every fourth adjustment. *If you ignore this Warning, your backrest posts could become loose or disconnected from the wheelchair, and you could fall, tip over or lose control of the wheelchair and seriously injure yourself or others or damage the wheelchair.*

Note: If your backrest is set to 8-½", 9", or 9-½" and you need to adjust the backrest height, the following procedure applies:

1. Remove the backrest upholstery. See "Velcro®-Style Adjustable Back Upholstery" or "Tension Adjustable by Straps Back Upholstery" on pages 7-1 to 7-3.
2. If your backrest is set to 8-½" and if you are setting the backrest at 9" or 9-½":
 - a. Remove the backrest from the backrest brackets. See "Replacing the Backrest (TR and YR Series 2)" on page 4-9.
 - b. Remove the top end caps. See Figure 4-9.
 - c. If the backrest is titanium, remove the long end plugs (see Figure 4-9) and install the short end plugs. If the backrest is aluminum, skip to Step 2.d.
 - d. Install the backrest sleeve in each backrest tube. See Figure 4-9.
 - e. Remove the threaded post plugs from the bottom end of the backrest posts (see Figure 4-9) and insert the backrest posts into the backrest.

CHAPTER 4: BACKRESTS AND PUSH HANDLES

- f. Align the backrest posts inside the backrest so that the desired hole in the backrest post aligns with the second lowest hole in the backrest. See Figure 4-10.
- g. Secure the backrest posts inside the backrest and the backrest to the bracket using the Allen screws and locknuts. Note that the Allen screws used to secure the backrest posts inside the backrest will also serve to secure the backrest to the brackets. See Figure 4-10. See “Replacing the Backrest (TR and YR Series 2)” on page 4-9. Proceed to Step 7.

Figure 4-9
Adjusting the Backrest Height

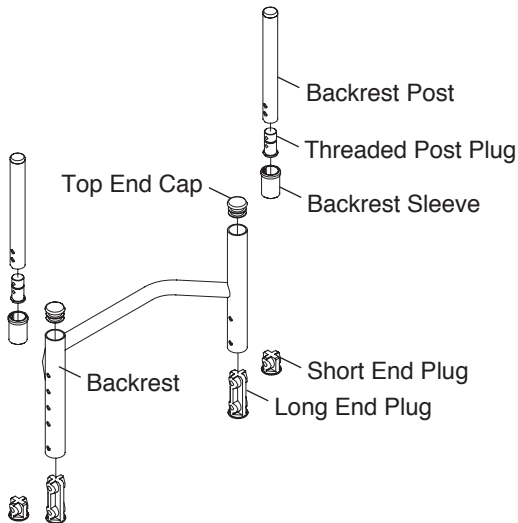
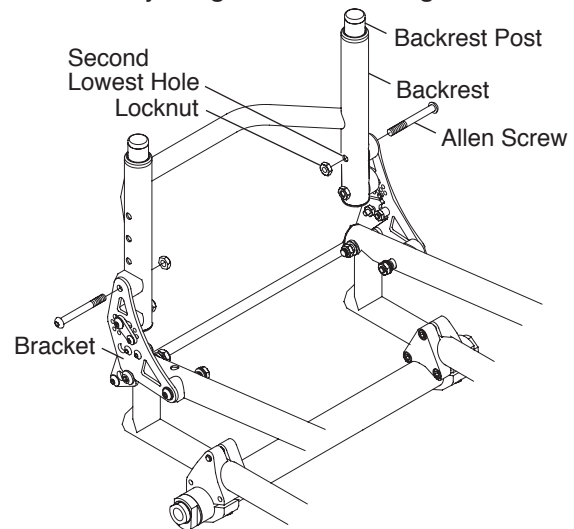
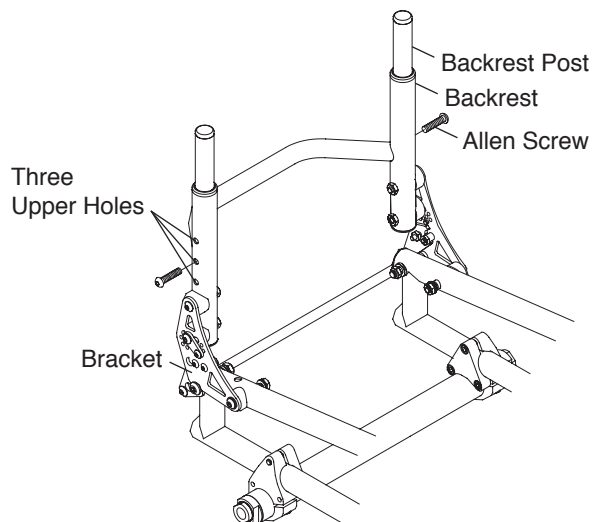

Figure 4-10
Adjusting the Backrest Height



3. If your backrest is set to 8-½” and if you are setting the backrest at 10” to 12-½”:
 - a. Remove the top end caps. See Figure 4-9
 - b. Install the backrest sleeve in each backrest tube. See Figure 4-9.
 - c. Keeping the threaded post plugs on the bottom end of the backrest posts, insert the backrest posts into the backrest.
 - d. Align the backrest posts inside the backrest so that the desired hole in the backrest post aligns with one of the upper 3 holes in the backrest. See Figure 4-11.
 - e. Secure the backrest posts inside the backrest and the backrest to the bracket using the Allen screws. See Figure 4-11. Proceed to Step 7.

Figure 4-11
Adjusting The Backrest Height



CHAPTER 4: BACKRESTS AND PUSH HANDLES

4. If your backrest is set to 9" or 9-½" and if you are setting the backrest at 8-½":
 - a. Remove the backrest from the backrest brackets. See "Replacing the Backrest (TR and YR Series 2)" on page 4-9.
 - b. Remove the backrest posts from the backrest. See Figure 4-9.
 - c. Remove the backrest sleeves from the backrest. See Figure 4-9.
 - d. Insert the top end caps in the backrest. See Figure 4-9.
 - e. If the backrest is titanium, remove the short end plugs (see Figure 4-9) and install the long end plugs in the bottom ends of the backrest.
 - f. Secure the backrest to the brackets using the Allen screws. See Figure 4-12. See "Replacing the Backrest (TR and YR Series 2)" on page 4-9. Proceed to Step 7.

Figure 4-12
Adjusting the Backrest Height

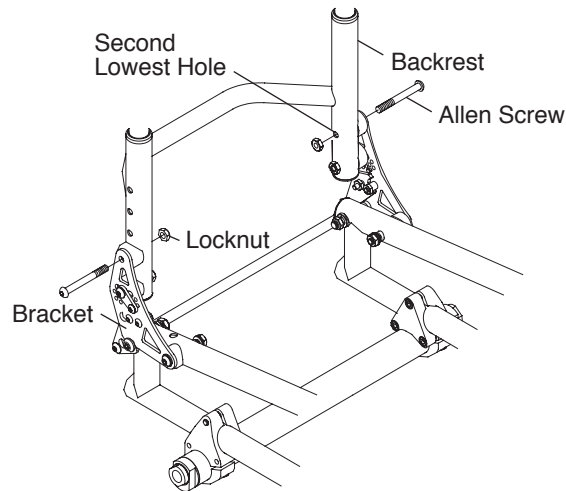

5. If your backrest is set to 9" and if you are setting the backrest at 9-½" or if your backrest is set to 9-½" and if you are setting the backrest to 9":
 - a. Remove the backrest from the backrest bracket. See "Replacing the Backrest (TR and YR Series 2)" on page 4-9.
 - b. Reposition the backrest posts inside the backrest so that the desired hole in the backrest post aligns with the second lowest hole in the backrest and with the bracket. See figure 4-13.
 - c. Secure the backrest posts inside the backrest and the backrest to the bracket using the Allen screws and locknuts. Note that the Allen screws used to secure the backrest posts inside the backrest will also secure the backrest to the brackets. See Figure 4-10. See "Replacing the Backrest (TR and YR Series 2)" on page 4-9. Proceed to Step 7.
6. If your backrest is set to 9" or 9-½" and if you are setting it to 10" to 12-½":
 - a. Remove the backrest from the backrest brackets. See "Replacing the Backrest (TR and YR Series 2)" on page 4-9.
 - b. Remove the backrest posts from the backrest. See Figure 4-9.
 - c. Install the threaded cane plugs in the bottom end of the backrest posts (see Figure 4-9) and reinstall the backrest posts in the backrest tubes.
 - d. If the backrest is titanium, remove the short end plugs (see Figure 4-9) and install the long end plugs in the bottom of the backrest tubes.
 - e. Align the backrest canes inside the backrest tubes so that the desired holes in the backrest canes align with one of the top three holes in the backrest tubes. See Figure 4-11.
 - f. Secure the backrest posts inside the backrest using the Allen screws. See Figure 4-11.
 - g. Secure the backrest to the brackets. See "Replacing the Backrest (TR and YR Series 2)" on page 4-9. Proceed to Step 7.

CHAPTER 4: BACKRESTS AND PUSH HANDLES

7. Reinstall the backrest upholstery and adjust the upholstery to the desired tautness. See “Velcro®-Style Adjustable Back Upholstery” or “Tension Adjustable by Straps Back Upholstery” on pages 7-1 to 7-3.

Note: If your backrest is set to 10” to 12-½” and you need to adjust the backrest height, the following procedures apply:

1. Remove the backrest upholstery. See “Velcro®-Style Adjustable Back Upholstery” or “Tension Adjustable by Straps Back Upholstery” on pages 7-1 to 7-3.
2. Remove the backrest from the backrest brackets. See “Replacing the Backrest (TR and YR Series 2)” on page 4-9.
3. If your backrest is to be set at 9” or 9-½”:
 - a. Remove the backrest posts from the backrest. See Figure 4-11.
 - b. If the backrest is titanium, remove the long end plugs in the bottom ends of the backrest and install the short end plugs. See Figure 4-9.
 - c. Remove the threaded plugs in the bottom ends of the backrest posts. See Figure 4-9.
 - d. Reinstall the backrest posts in the backrest tubes.
 - e. Align the backrest posts inside the backrest so that the desired holes in the backrest posts align with the second lowest holes in the backrest. See Figure 4-10.
 - f. Secure the backrest posts inside the backrest and the backrest to the bracket using the Allen screws and locknuts. Note that the Allen screws used to secure the backrest posts inside the backrest will also serve to secure the backrest to the backrest brackets. See Figure 4-10. Proceed to Step 5.
4. If your backrest is to be set at 8-½”:
 - a. Remove the backrest posts from the backrest. See Figure 4-11.
 - b. If the backrest is titanium, make sure that the long end plugs are installed in the bottom ends of the backrest tubes. See Figure 4-9.
 - c. Remove the backrest sleeve from each backrest tube. See Figure 4-9.
 - d. Install the top end cap in each backrest tube. See Figure 4-9.
 - e. Secure the backrest to the bracket using the Allen screws. See Figure 4-12.
5. Reinstall the backrest upholstery and adjust the upholstery to the desired tautness. See “Velcro®-Style Adjustable Back Upholstery” or “Tension Adjustable by Straps Back Upholstery” on pages 7-1 to 7-3.

Adjusting the Backrest Height (TR Series 3)

Tools Needed:

- 5/32” Allen Wrench

Note: In order to adjust the backrest height, it is helpful to remove the backrest upholstery. Therefore, make a note of the tautness of the backrest upholstery before removing it so you can reinstall it to approximately the same degree of tautness.

1. Remove the backrest pad. See “Velcro®-Style Adjustable Back Upholstery” or “Tension Adjustable by Straps Back Upholstery” on pages 7-1 to 7-3.
2. On both sides of the chair, remove the Allen screw that secures the backrest post inside the backrest. See Figure 4-13.
3. Reposition both backrest posts to the desired height inside the backrest, and reinsert and securely tighten the two Allen screws.
4. Make sure both backrest posts are the same height in the backrest.
5. Reinstall the backrest upholstery. See “Velcro®-Style Adjustable Back Upholstery” or “Tension Adjustable by Straps Back Upholstery” on pages 7-1 to 7-3.

CHAPTER 4: BACKRESTS AND PUSH HANDLES

⚠ WARNING

The threads on the Allen screws that secure the backrest posts to the backrest have been treated with Vibra-TITE® VC-3, a locking and sealing coating, to reduce the possibility that they will become loose. You should be able to adjust the backrest height approximately four times without reapplying thread lock to these screws. TiLite requires that you reapply Vibra-TITE® VC-3 after every fourth adjustment. *If you ignore this Warning, your backrest posts could become loose or disconnected from the wheelchair, you could fall, tip over or lose control of the wheelchair and seriously injure yourself or others or damage the wheelchair.*

Figure 4-13
Adjusting the Backrest Height

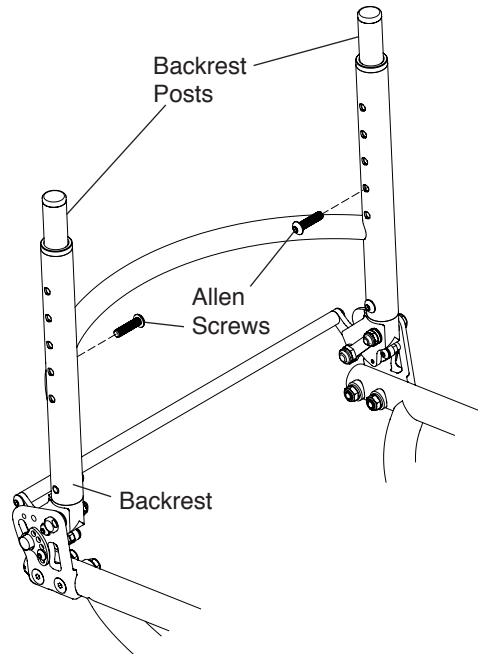

Replacing the Backrest

(TR and YR Series 2)

Tools Needed:

- 7/16" Open End Wrench
- 5/32" Allen Wrench

1. Remove the backrest upholstery. See "Velcro®-Style Adjustable Back Upholstery" or "Tension Adjustable by Straps Back Upholstery" on pages 7-1 to 7-3.
2. Remove the backrest posts. See "Adjusting the Backrest Height (TR and YR Series 2)" on pages 4-5 to 4-8.
3. Remove the backrest sleeves. See Figure 4-9.
4. Remove the two Allen screws that secure each backrest bracket to the backrest. Note the order of the washers and spacers and the position of the backrest cord, if any. See Figures 4-10, 4-11 and 4-12.
5. Install the new backrest and securely tighten the Allen screws removed in Step 4.
6. Install the backrest sleeves in the new backrest.
7. If the backrest is titanium, install the end plugs, removed in Step 3, in the new backrest.
8. Reinstall the backrest posts removed in Step 2.
9. Reinstall the backrest upholstery removed in Step 1.

CHAPTER 4: BACKRESTS AND PUSH HANDLES

Replacing the Backrest (TR Series 3)

Tools Needed:

- 5/32" Allen Wrench

1. Remove the backrest upholstery. See "Velcro®-Style Adjustable Back Upholstery" or "Tension Adjustable by Straps Back Upholstery" on pages 7-1 to 7-3.
2. Remove the backrest posts. See "Adjusting the Backrest Height (TR and YR Series 3)" on pages 4-8 and 4-9.
3. Remove the backrest sleeves. See Figure 4-9.
4. Remove the two Allen screws (one on each side of the chair) and remove the backrest. See Figure 4-14.
5. Install the new backrest and securely tighten the two Allen screws.
6. Install the backrest sleeves in the new backrest.
7. Reinstall the backrest posts.
8. Reinstall the backrest upholstery.

⚠ WARNING

The threads on the Allen screws that secure the backrest posts to the backrest have been treated with a Vibra-TITE® VC-3, a locking and sealing coating, to reduce the possibility that they will become loose. TiLite requires that you reapply Vibra-TITE® VC-3 each time your backrest is replaced. *If you ignore this Warning, your backrest posts could become loose or disconnected from the wheelchair, and you could fall, tip over or lose control of the wheelchair and seriously injure yourself or others or damage the wheelchair.*

Figure 4-14
Replacing the Backrest

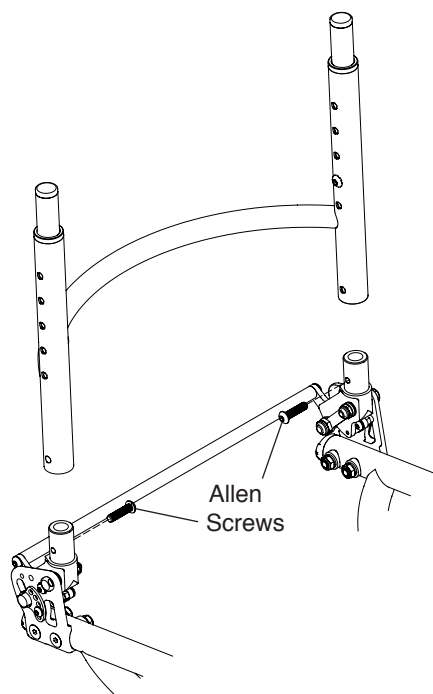

Non-Folding Fixed Height & Angle Backrest

If your chair has a non-folding Titanium Fixed Height & Angle Backrest, you cannot adjust the backrest height or the backrest angle.

Bolt-On Push Handles

Note: Bolt-On Push Handles should only be used on aluminum backrests.

Mounting

Tools Needed:

- 3/16" Allen Wrench
- 5/32" Allen Wrench

1. See Figure 4-15 for the correct location to mount the Bolt-On Push Handles to the rigidizer bar.
2. Assemble the two halves of the clamp around the rigidizer bar. See Figure 4-16.
3. Using the 3/16" Allen wrench, insert the 1" Allen screw through a washer into the bottom hole on the clamp and loosely tighten.
4. Insert the push handle into the clamp and align the holes in the push handle with the two upper holes in the clamp.
5. Using the 5/32" Allen wrench, insert the two 1-1/8" Allen screws through the washers, the two halves of the clamp and the push handle and securely tighten.
6. Make sure the push handle is correctly positioned for proper pushing and securely tighten the 1" Allen screw.

⚠ WARNING

Your assistant or attendant should NEVER attempt to lift a wheelchair up a curb, step or flight of stairs by lifting on any removable (detachable) parts, such as Bolt-On Push Handles. Similarly, your assistant or attendant should NEVER attempt to lower a wheelchair down a curb, step or flight of stairs by holding onto any removable (detachable) parts, such as the Bolt-On Push Handles. *If you ignore this Warning, the removable parts, such as the bolt-on push*

CHAPTER 4: BACKRESTS AND PUSH HANDLES

handles, could detach from the wheelchair causing you to fall, tip over or lose control of the wheelchair and seriously injure yourself or others or damage the wheelchair.

Figure 4-15
Location for Bolt-On Push Handles

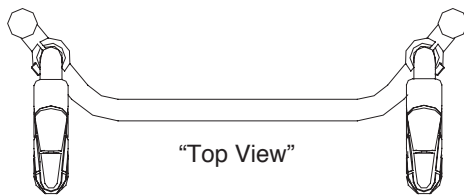
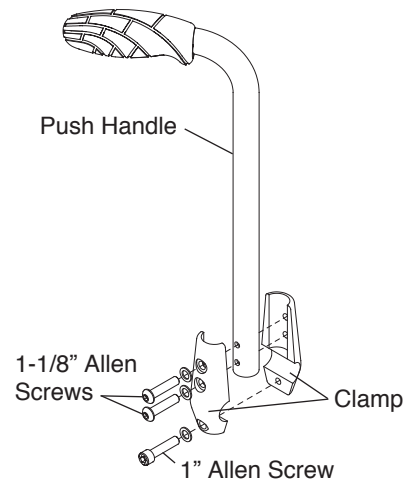

Figure 4-16
Bolt-On Push Handles



Removing

Tools Needed:

- 3/16" Allen Wrench
- 5/32" Allen Wrench

1. Using the 3/16" Allen wrench, remove the 1" Allen screw. See Figure 4-16.
2. Using the 5/32" Allen wrench, remove the 1-1/8" Allen screws.
3. Remove the clamp and handle.

Adjustable Height Push Handles

Note: Adjustable Height Push Handles should only be used on aluminum backrests.

Mounting

Tools Needed:

- 3/16" Allen Wrench

1. See Figure 4-17 for the correct location to mount the Adjustable Height Push Handles.
2. Assemble the two halves of the clamp around the rigidizer bar. See Figure 4-18.
3. Insert the four Allen screws into the two halves of the clamp and securely tighten.
4. Insert the push handle through the clamp until the handle is at the desired height and securely tighten the adjustable handle.

Note: The adjustable handle operates as a ratchet, thereby enabling the user to easily disengage and engage the clamp for purposes of repositioning or removing the push handles.

⚠ WARNING

Your assistant or attendant should NEVER attempt to lift a wheelchair up a curb, step or flight of stairs by lifting on any removable (detachable) parts, such as adjustable height push handles. Similarly, your assistant or attendant should NEVER attempt to lower a wheelchair down a curb, step or flight or stairs by holding onto any removable (detachable) parts, such as the Adjustable Height Push Handles. *If you ignore this Warning, the removable parts, such as the adjustable height push handles, could detach from the wheelchair causing you to fall, tip over or lose control of the wheelchair and seriously injure yourself or others or damage the wheelchair.*

CHAPTER 4: BACKRESTS AND PUSH HANDLES

Figure 4-17
Adjustable Height Push Handles

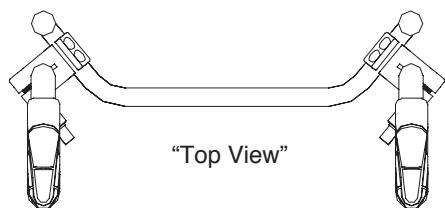
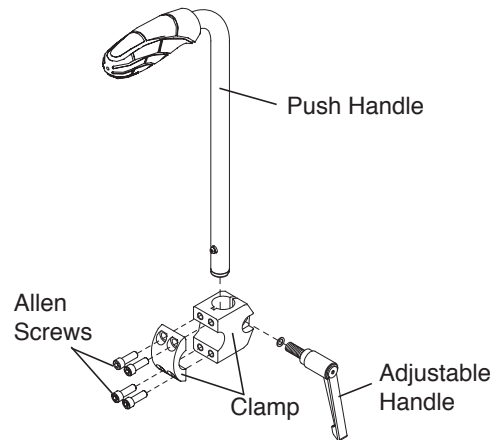

Figure 4-18
Adjustable Height Push Handles



Removing

Tools Needed:

- 3/16" Allen Wrench

1. Remove the four Allen screws. See Figure 4-18.
2. Remove the clamp and handle.

Swing Away Armrest

(TR and YR Series 2 prior to October 2010)

To swing away the armrest, lift the armrest and rotate the armrest away from the chair. See Figure 5-1. Make sure to lift the armrest until the armrest pins are above the notch on the receiver. See Figure 5-1.

To replace the armrest, rotate the armrest back towards the chair and gently push it down into place. See Figure 5-1. Make sure the armrest pins are in the notch on the receiver.

Note: The Swing Away Armrests pivot on nylon sleeves, located inside the receiver. If the armrest does not rotate properly, remove the armrest, clean the armrest and inside the receiver thoroughly. If this does not solve the problem, check the nylon sleeves for wear.

Figure 5-1
Operating the Swing Away Armrest

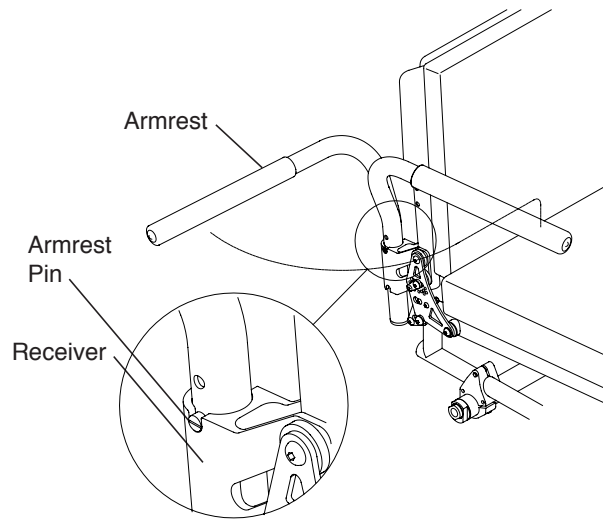

Adjusting the Height of the Swing Away Armrest

Tools Needed:

- Two 5/32" Allen Wrenches

1. Remove the armrest from the receiver.
2. Remove both armrest pins. See Figure 5-2.
3. Reassemble the armrest pins in the desired location on the armrest (in 3/4" increments).
4. Securely tighten both armrest pins in the new location.
5. Reinstall the armrest in the receiver.

⚠ WARNING

The threads on the armrest pins are treated with Vibra-TITE® VC-3, a locking and sealing coating. You should be able to adjust the height of the armrest pins approximately four times without reapplying the coating. TiLite requires that you reapply Vibra-TITE® VC-3 after every fourth adjustment. *If you ignore this Warning, your armrest pins could become loose or fall off and you could fall, tip over or lose control of the wheelchair and seriously injure yourself or others or damage the wheelchair.*

Figure 5-2
Swing Away Armrest Adjustments

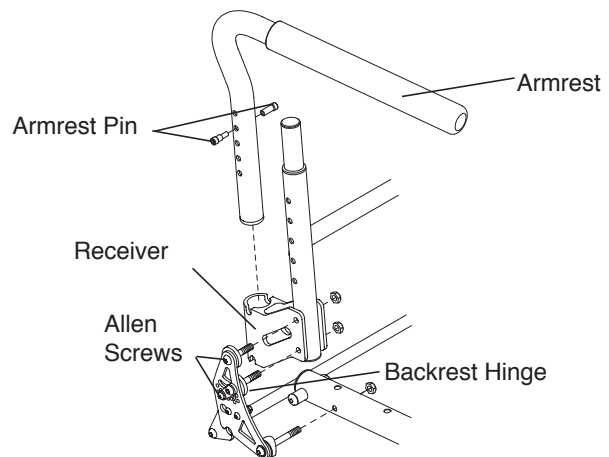

CHAPTER 5: ARMRESTS

Adjusting the Height of the Receiver

Tools Needed:

- 5/32" Allen Wrench
- 7/16" Open End Wrench

The armrest receiver can be inverted to achieve a higher or lower height range for the Swing Away Armrest. See Figure 5-3.

1. Remove the armrest from the receiver.
2. Remove the two Allen screws that pass through the backrest hinge, the receiver and the backrest tube. See Figure 5-2. Do not remove the Allen screws that attach the backrest hinge to the seat tube.
3. Remove and invert the receiver and slide it back into place between the backrest tube and the backrest hinge, making sure to align the holes in the receiver with the holes in the backrest tube and the backrest hinge.
4. Reinsert the Allen screws through the reassembled backrest hinge, the inverted receiver and the backrest tube and securely tighten the Allen screws and locknuts.
5. Reinstall the armrest in the armrest receiver.

Figure 5-3
Armrest Height Ranges

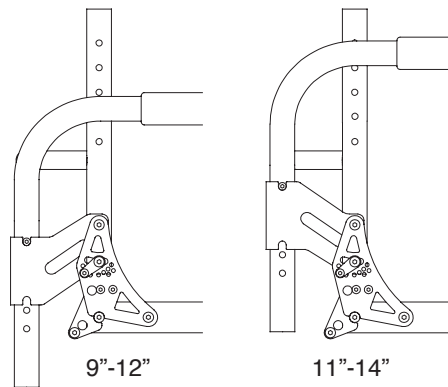

Swing Away Armrest

(TR and YR Series 2 after October 2010)

To swing away the armrest, lift the armrest and rotate the armrest away from the chair. See Figure 5-4. Make sure to lift the armrest until the armrest saddle is above the notch on the receiver.

To replace the armrest, rotate the armrest back towards the chair and gently push it down into place. See Figure 5-4. Make sure the armrest saddle is in the notch on the receiver.

Note: The Swing Away Armrests pivot on nylon sleeves, located inside the receiver. If the armrest does not rotate properly, remove the armrest, clean the armrest and inside the receiver thoroughly. If this does not solve the problem, check the nylon sleeves for wear.

Figure 5-4
Operating the Swing Away Armrest

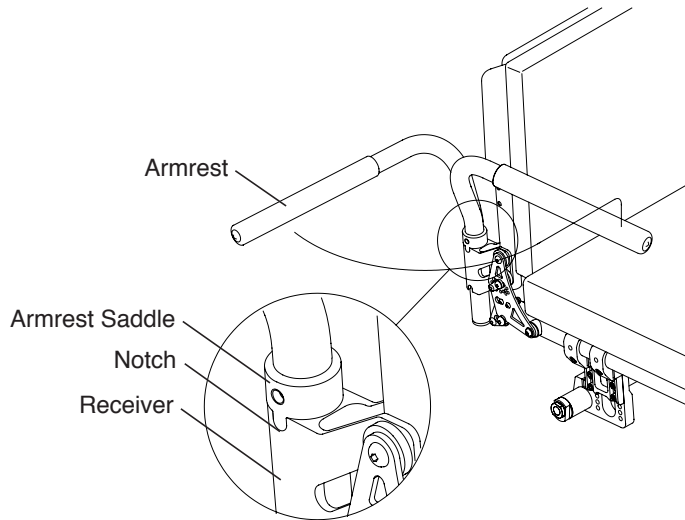

Adjusting the Height of the Swing Away Armrest

Tools Needed:

- 5/32" Allen Wrenches

1. Remove the armrest from the receiver.
2. Remove the Allen screw and washer securing the armrest saddle. See Figure 5-5.
3. Reassemble the armrest saddle in the desired location on the armrest (in 3/4" increments).
4. Securely tighten the Allen screw.
5. Reinstall the armrest in the receiver.

Figure 5-5
Swing Away Armrest Adjustments

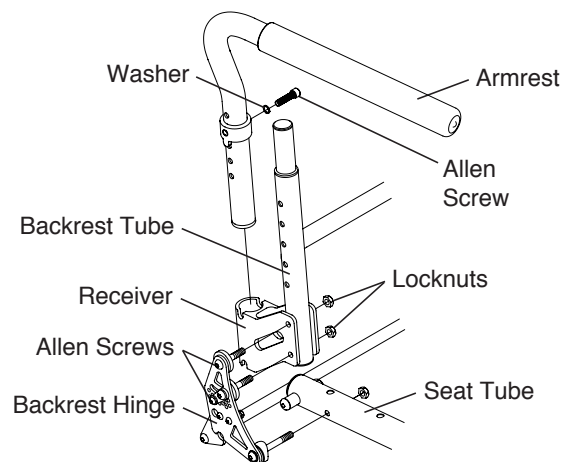

Adjusting the Height of the Receiver

Tools Needed:

- 5/32" Allen Wrench
- 7/16" Open End Wrench

The armrest receiver can be inverted to achieve a higher or lower height range for the Swing Away Armrest. See Figure 5-6.

1. Remove the armrest from the receiver.
2. Remove the two Allen screws that pass through the backrest hinge, the receiver and the backrest tube. See Figure 5-5. Do not remove the Allen screws that attach the backrest hinge to the seat tube.
3. Remove and invert the receiver and slide it back into place between the backrest tube and the backrest hinge, making sure to align the holes in the receiver with the holes in the backrest tube and the backrest hinge.
4. Reinsert the Allen screws through the reassembled backrest hinge, the inverted receiver and the backrest tube and securely tighten the Allen screws and locknuts.
5. Reinstall the armrest in the armrest receiver.

CHAPTER 5: ARMRESTS

Figure 5-6
Armrest Height Ranges

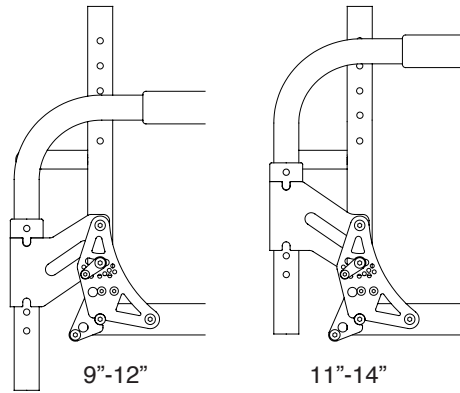

Swing Away Armrest

(TR Series 3)

To swing away the armrest, lift the armrest and rotate the armrest away from chair. See Figure 5-7. Make sure to lift the armrest until the armrest stop is above the notch on the receiver.

To replace the armrest, rotate the armrest back towards the chair and gently push it down into place. See Figure 5-7. Make sure the armrest stop is in the notch on the receiver.

Note: The Swing Away Armrests pivot on nylon sleeves, located inside the receiver. If the armrest does not rotate properly, remove the armrest, clean the armrest and inside the receiver thoroughly. If this does not solve the problem, check the nylon sleeves for wear.

Figure 5-7
Operating the Swing Away Armrest

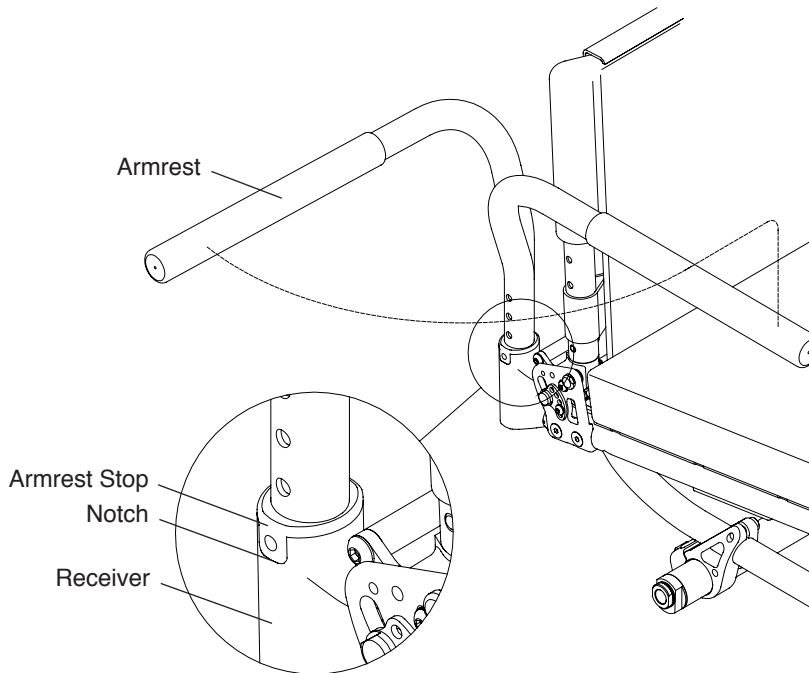

Adjusting the Angle

Tools Needed:

- 7/16" Open End Wrench
- 5/32" Allen Wrench

1. Remove the armrest from the receiver.
2. On one side of the chair, loosen, but do not remove, the nylock nuts while holding the locking block in position with your finger. See Figure 5-8.
3. To change the angle of the armrest, move the locking block one or more teeth up or down until the desired armrest angle is achieved.
4. Make sure the locking block teeth are fully engaged with the teeth on the receiver, and securely tighten the nylock nuts.
5. Repeat this procedure on the other side of the chair.

Figure 5-8
Adjusting the Angle

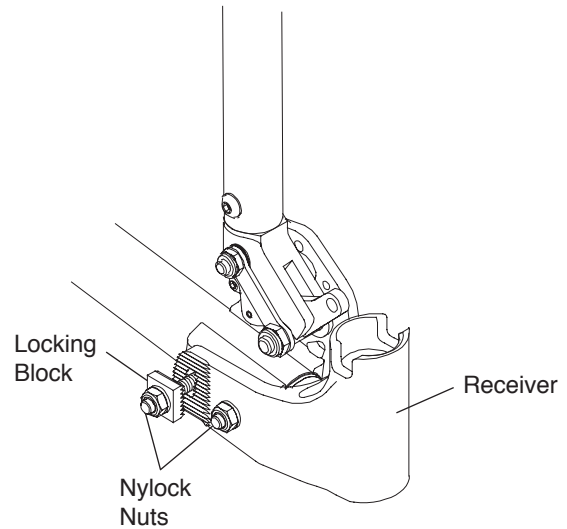

Adjusting the Height

Tools Needed:

- 5/32" Allen Wrench

1. Remove the armrest from the receiver.
2. Remove the Allen screw and washer securing the armrest stop. See Figure 5-9.
3. Reassemble the armrest stop in the desired location on the armrest (in 3/4" increments).
4. Securely tighten the Allen screw.
5. Reinstall the armrest in the receiver.

Figure 5-9
Adjusting the Height

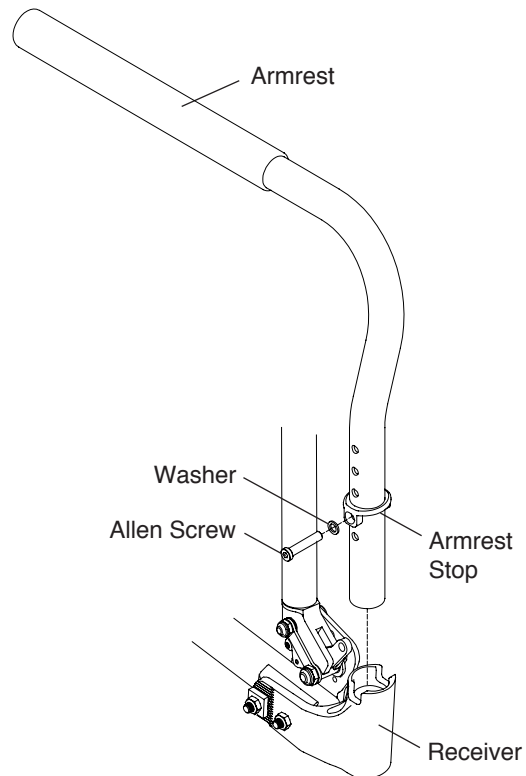

CHAPTER 5: ARMRESTS

Desk Arm with Rigid Side Guard and Desk Arm with Rigid Side Guard and Transfer Loop

⚠ WARNING

If you own a TR or YR Series 2 chair, make sure the locking pin activated by the height adjustment lever is securely engaged in the desk arm housing (see Figure 5-10), before applying weight to the armrest. *If you ignore this Warning, you could fall, tip over or lose control of the wheelchair and seriously injure yourself or others or damage the wheelchair.*

⚠ WARNING

Make sure the armrest is securely engaged in the desk arm housing (see Figure 5-11), before applying weight to the armrest. *If you ignore this Warning, you could fall, tip over or lose control of the wheelchair and seriously injure yourself or others or damage the wheelchair.*

Note: Never lift your chair using the Desk Arms.

Adjusting the Armrest Height

1. Pull up on the height adjustment lever to permit the armrest to be raised or lowered to the desired height. See Figures 5-10 and 5-11.
2. After repositioning the armrest to the desired height, release the height adjustment lever, pressing the handle against the desk arm housing to lock the armrest in that position. The positioning holes are in 1/2" increments.

Removing

1. To remove the desk arm assembly, press and hold the release lever. See Figures 5-10 and 5-11.
2. While holding the release lever, lift the desk arm assembly to remove it from the desk arm mount. See Figure 5-12.

Replacing

Slide the desk arm housing into the desk arm mount. See Figure 5-12.

⚠ WARNING

Make sure the desk arm housing securely locks in the desk arm mount (see Figure 5-12), before applying weight to the armrest. *If you ignore this Warning, you could fall, tip over or lose control of the wheelchair and seriously injure yourself or others or damage the wheelchair.*

Figure 5-10

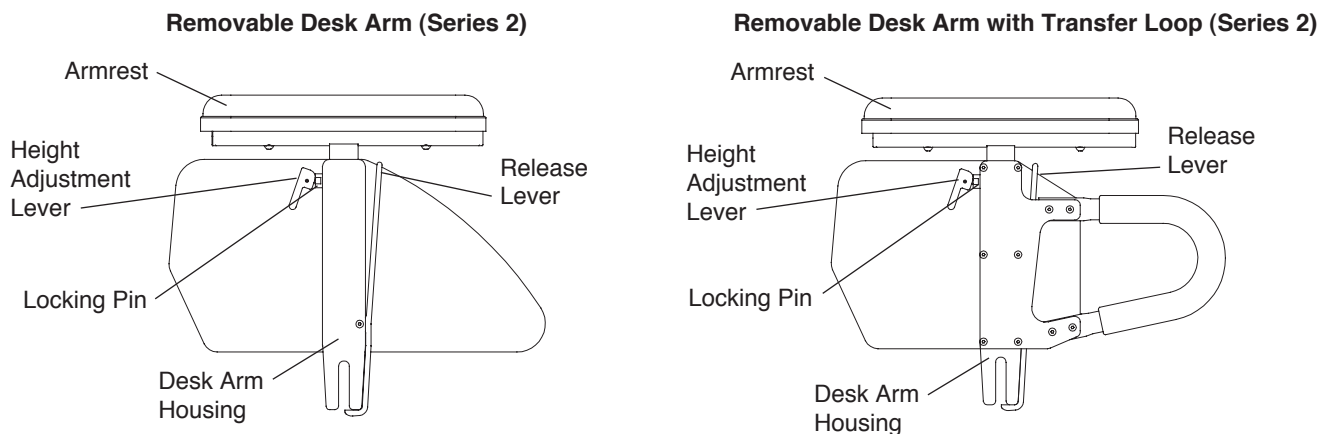

Figure 5-11

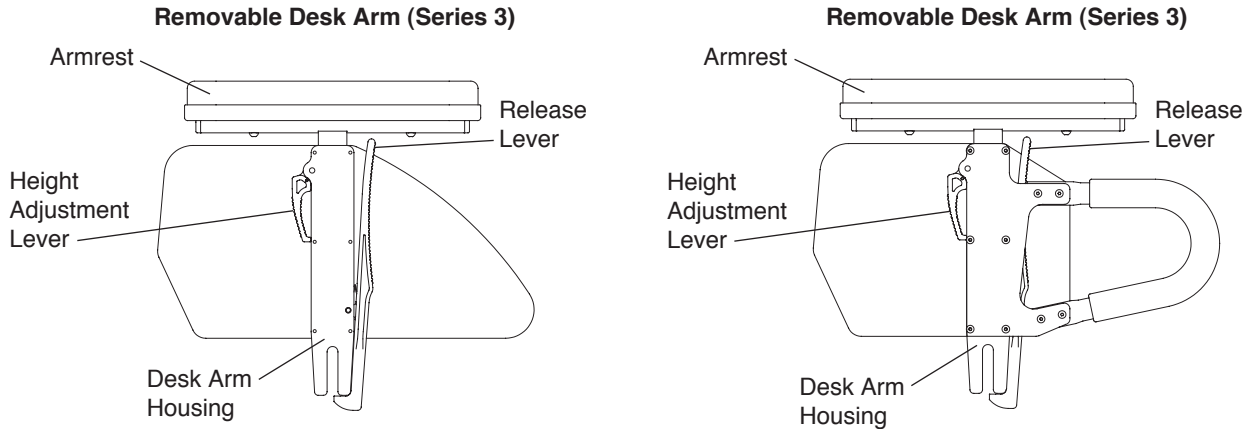
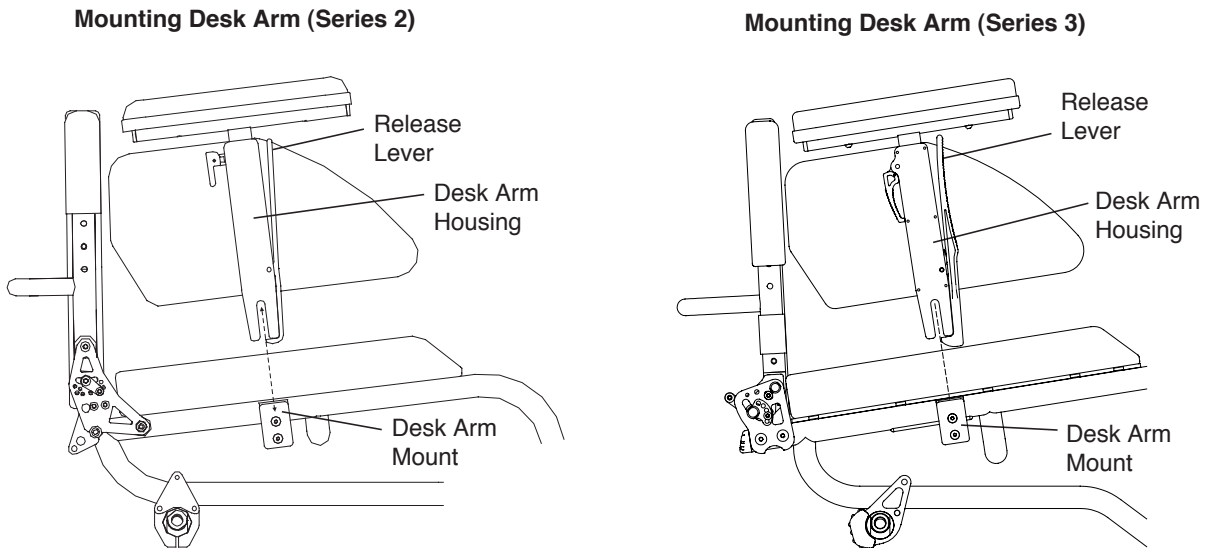

Figure 5-12



Swing Away Flip-Back Armrest

(TR Series 3)

To flip back the armrest, raise the front of the armrest and rotate it straight back as far as possible. Reverse this procedure to return the armrest to its original position. See Figure 5-13.

To swing away the armrest, lightly lift up on the armrest and rotate the armrest away from the chair. See Figure 5-13. To replace the armrest, swing it back towards the chair and gently push it back down into place.

Note: The Swing Away Armrests pivot on nylon sleeves located inside the armrest receiver. If the armrest does not rotate properly, check the sleeves for wear.

CHAPTER 5: ARMRESTS

Figure 5-13
Swing Away Flip-Back

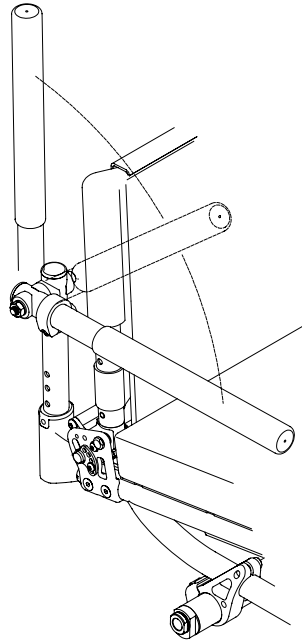

Adjusting the Armrest Height

Tools Needed:

- 5/32" Allen Wrench

1. Remove the armrest from the receiver.
2. Remove the Allen screw and washer securing the armrest stop. See Figure 5-14.
3. Reassemble the armrest stop in the desired location on the armrest upright (in 1/2" increments).
4. Securely tighten the Allen screw.
5. Reinstall the armrest in the receiver.

Figure 5-14
Adjusting the Armrest Height

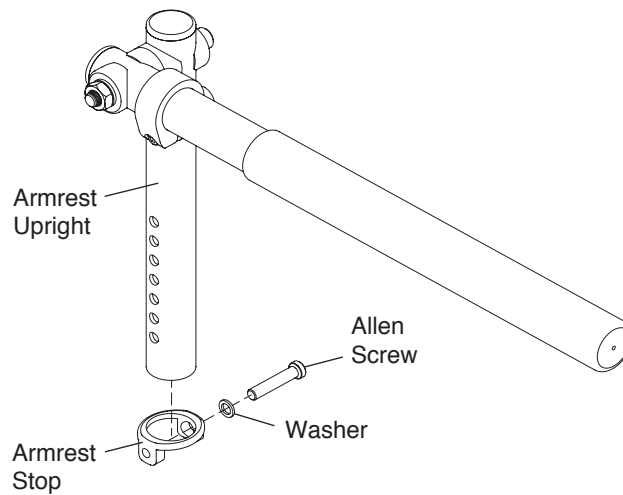

Adjusting the Armrest Angle

Tools Needed:

- 5/32" Allen Wrench

1. To adjust the angle at which the armrest sits when in the down position, loosen, but do not remove, the Allen screw that secures the stop clamp. See Figure 5-15.
2. Slide the stop clamp forward on the armrest to lower the angle at which the armrest sits in the down position, or slide the stop clamp rearward on the armrest to raise the angle.
3. Securely tighten the Allen screw to fix the stop clamp in place.

⚠ WARNING

Make sure that the stop clamp is securely tightened before applying weight to the armrest. *If you ignore this Warning, you could fall, tip over or lose control of the wheelchair and seriously injure yourself or others or damage the wheelchair.*

Figure 5-15
Adjusting the Armrest Angle

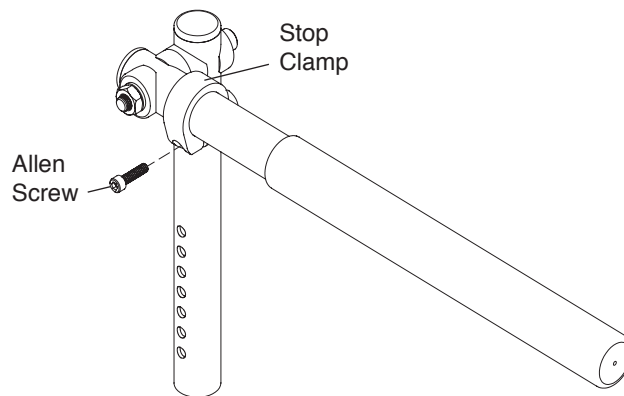

Cloth Side Guards

Removing/Replacing

1. Lift up on the seat cushion and remove it from the chair.
2. Separate the Cloth Side Guards from the seat upholstery and the back upholstery. See Figure 6-1.
3. If desired, install new Cloth Side Guards onto the seat and back upholstery.

Note: The fastening flaps that secure the Cloth Side Guards to the back upholstery wrap around the outside of the back uprights and under the back upholstery flap.

4. Replace the seat cushion.

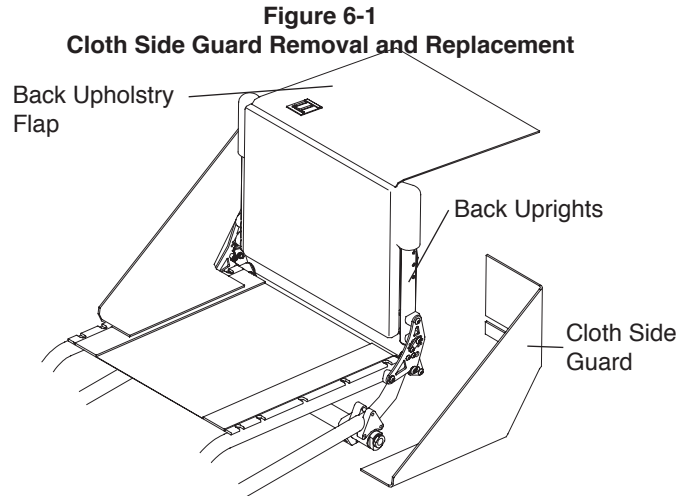

Rigid Removable and Quad Removable Side Guards (Aluminum and Carbon Fiber)

Using Rigid Side Guards

To remove either type of Rigid Side Guard, lift the side guard out of the side guard mount by grasping it at the top or place finger in the hole and pull it upward. See Figure 6-2. To replace, place the bracket into the slot between the side guard mount and the clamp and push down.

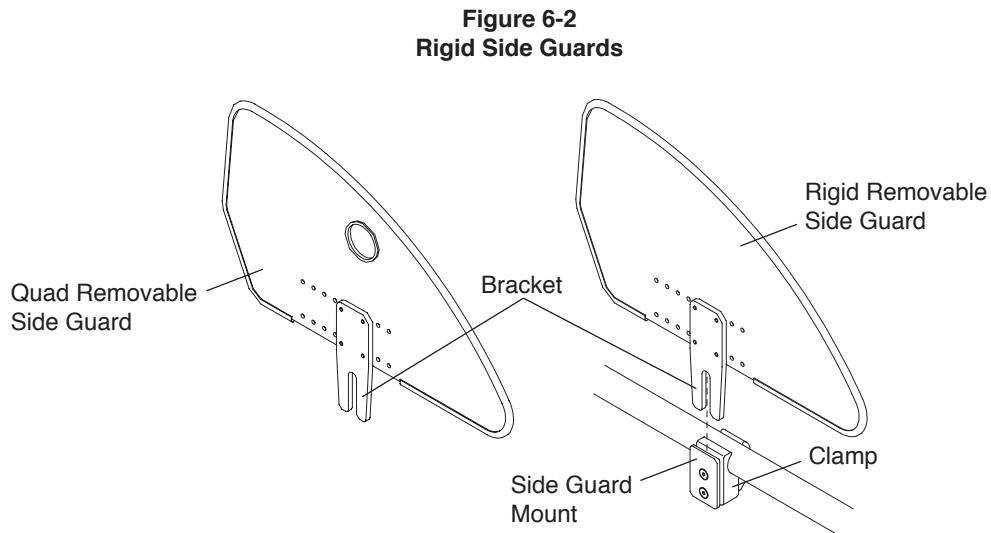

CHAPTER 6: SIDE GUARDS

Adjusting

(TR and YR Series 2)

Tools Needed:

- 1/8" Allen Wrench

You can adjust the “snugness” of the fit of the side guard bracket in the side guard mount by loosening or tightening the two Allen screws in the side guard mount. See Figure 6-3.

Either type of Rigid Side Guard can be made “non-removable” by firmly tightening the two Allen screws in the side guard mount while the side guard is installed.

Figure 6-3
Replacing Rigid Side Guard

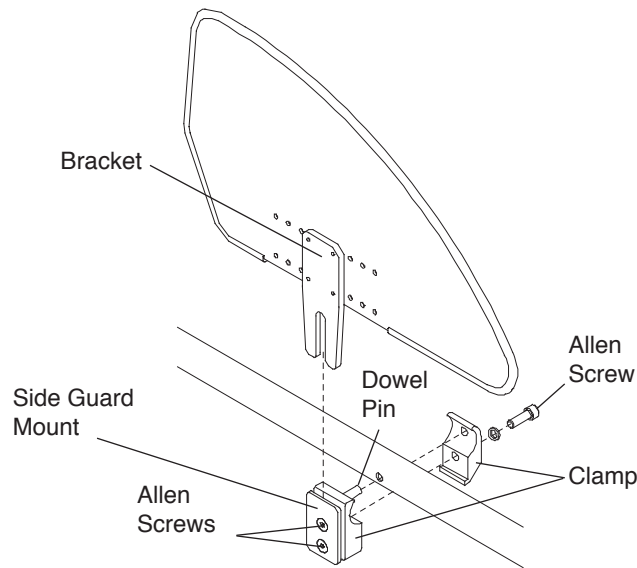

Removing the Rigid Side Guard Assembly

(TR and YR Series 2)

Tools Needed:

- 3/16" Allen Wrench

To remove the entire side guard assembly, including the clamp:

1. Remove the side guard from the side guard mount.
2. Remove the Allen screw that secures the two halves of the clamp to the frame. See Figure 6-3.

Reinstalling the Rigid Side Guard Assembly

(TR and YR Series 2)

Tools Needed:

- 3/16" Allen Wrench

1. Align the two halves of the clamp around the seat tube of the chair frame. See Figure 6-3.

Note: The half of the clamp to which the side guard mount is attached has a dowel pin protruding from the clamp that must be inserted in the clamp hole in the frame.

2. Insert the Allen screw into the two halves of the clamp and securely tighten.
3. Insert the side guard bracket into the side guard mount and adjust the two Allen screws as described under “Adjusting (TR and YR Series 2)” on page 6-2.

Adjusting

(TR Series 3)

Note: Do not allow any portion of the clamp to extend passed either end of the frame rail located under the seat tube.

Tools Needed:

- 1/8" Allen Wrench

You can adjust the “snugness” of the fit of the side guard bracket in the side guard mount by loosening or tightening the two Allen screws in the side guard mount. See Figure 6-4.

Either type of Rigid Side Guard can be made “non-removable” by firmly tightening the two Allen screws in the side guard mount while the side guard is installed.

Figure 6-4
Replacing Rigid Side Guard

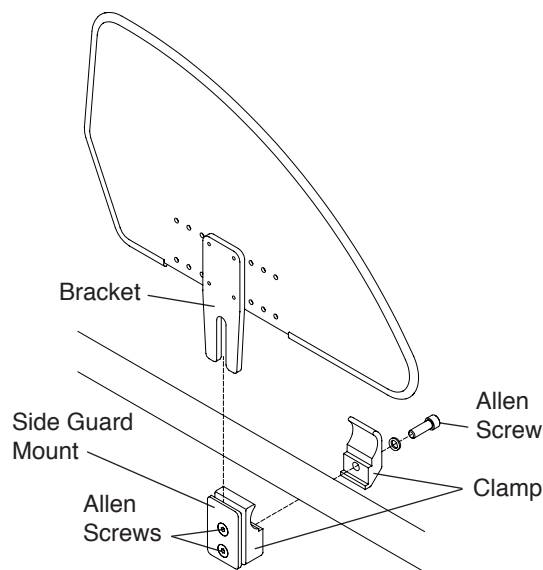

Removing the Rigid Side Guard Assembly

(TR Series 3)

Tools Needed:

- 3/16" Allen Wrench

To remove the entire side guard assembly, including the clamp:

1. Remove the side guard from the side guard mount.
2. Remove the Allen screw that secures the two halves of the clamp to the frame. See Figure 6-4.

Reinstalling the Rigid Side Guard Assembly

(TR Series 3)

Tools Needed:

- 3/16" Allen Wrench

1. Align the two halves of the clamp around the seat tube of the chair frame. See Figure 6-4.
2. Insert the Allen screws through the washers and into the two halves of the clamp and securely tighten.
3. Insert the side guard bracket into the side guard mount and adjust the two Allen screws as described under “Adjusting (TR Series 3)” on page 6-3.

CHAPTER 6: SIDE GUARDS

Fold-Down Rigid Side Guards (Aluminum and Carbon Fiber)

(TR and YR Series 2)

Using Fold-Down Side Guards

To fold down, simply remove the seat cushion and push the top of the side guard toward the seat sling. To unfold, simply pull the side guard up away from the seat sling. See Figure 6-5.

Figure 6-5
Fold-Down Side Guards

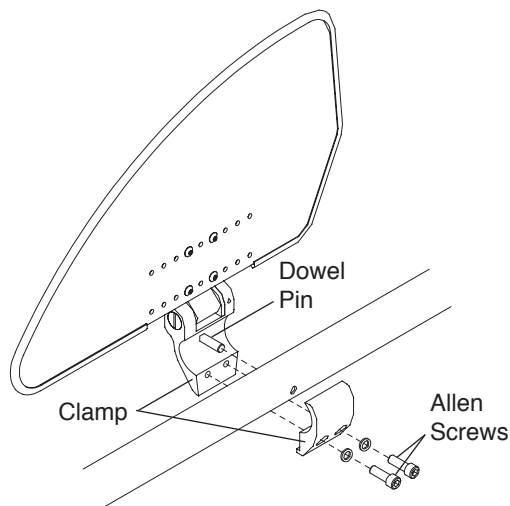

Removing

Tools Needed:

- 3/16" Allen Wrench

1. Remove the two Allen screws that secure the two halves of the side guard clamp. See Figure 6-5.
2. Remove the Fold-Down Side Guard clamp assembly.

Reinstalling

Tools Needed:

- 3/16" Allen Wrench

1. Align the two halves of the side guard clamp around the seat tube of the frame. See Figure 6-5.

Note: The half of the side guard clamp to which the side guard mount is attached has a dowel pin protruding from the clamp that must be inserted in the side guard clamp hole in the frame.

2. Insert the two Allen screws through the washers and the two halves of the clamp and securely tighten.

Fold-Down Rigid Side Guards (Aluminum and Carbon Fiber)

(TR Series 3)

Note: Do not allow any portion of the clamp to extend passed either end of the frame rail located under the seat tube.

Using Fold-Down Side Guards

To fold down, simply remove the seat cushion and push the top of the side guard toward the seat sling. To unfold, simply pull the side guard up away from the seat sling. See Figure 6-6.

Figure 6-6
Fold-Down Side Guards

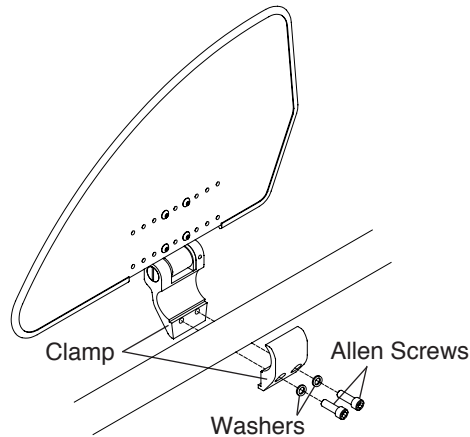

Removing

Tools Needed:

- 3/16" Allen Wrench

1. Remove the two Allen screws that secure the two halves of the side guard clamp. See Figure 6-6.
2. Remove the Fold-Down Side Guard clamp assembly.

Reinstalling

Tools Needed:

- 3/16" Allen Wrench

1. Align the two halves of the side guard clamp around the seat tube of the frame. See Figure 6-6.
2. Insert the two Allen screws through the washers and the two halves of the clamp and securely tighten.

Fendered Carbon Fiber Side Guard

Using Fendered Side Guards

Note: Do not allow any portion of the clamp to extend past either end of the frame rail located under the seat tube.

To remove the Fendered Side Guard, lift the side guard out of the side guard mount. To replace, place the bracket into the slot between the side guard mount and the clamp. Make sure the rearward end of the side guard is inside the stabilizer tab. See Figure 6-7.

To adjust the Fendered Side Guards, see "Adjusting (TR and YR Series 2)" on page 6-2 or "Adjusting (TR Series 3)" on page 6-3.

Figure 6-7
Fendered Carbon Fiber Side Guard

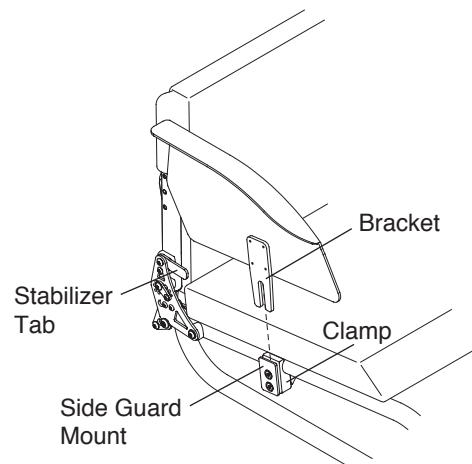

CHAPTER 6: SIDE GUARDS

ADJUSTABLE FENDERED SIDE GUARD (Aluminum)

(TR Series 3)

Mounting

Tools Needed:

- 5/64" Allen Wrench
- 5/32" Allen Wrench
- 3/16" Allen Wrench

Note: You may need to adjust the Tension Adjustable Seat Sling to gain access to the seat tube placement you desire. If this is necessary, see "Adjusting the Tension" on pages 7-3 and 7-4.

1. Insert Allen screw #1 through the conical washer, the slot in the rear cam, spacer and into the back mount. Do not tighten. See Figure 6-8.
2. Insert Allen screw #2 through the conical washer, the slot in the front cam and into the top hole of the outer clamp. Do not tighten.
3. Insert Allen screw #3 through the washer, outer clamp and into the inner clamp. Do not tighten.
4. Loosen but do not remove the eight Button Head Cap screws (four in each cam).
5. Adjust the side guard to the desired position, rotating the cams as needed and allowing the Allen screws to slide within the cam slots.
6. Once the desired side guard position has been achieved, tighten the eight Button Head Cap screws (four on each cam) using the 5/64" Allen wrench.
7. Using the 5/32" Allen wrench, securely tighten Allen screw #1.
8. Securely tighten Allen screw #2 in place using the 5/32" Allen wrench.
9. Securely tighten Allen screw #3 in place using the 3/16" Allen wrench.

⚠ WARNING

The threads on the Button Head Cap screws and Allen screws #1 and #2 have been treated with Vibra-TITE® VC-3, a locking and sealing coating, to reduce the possibility that they will become loose. You should be able to adjust the cams and/or sideguards approximately four times without reapplying the coating to these screws. If you repeatedly adjust the cams or remove the sideguard, TiLite requires that you reapply Vibra-TITE® VC-3 after every fourth adjustment. *If you ignore this Warning, you could fall, tip over or lose control of the wheelchair and seriously injure yourself or others or damage the wheelchair.*

Figure 6-8
Mounting/ Adjusting/ Removing

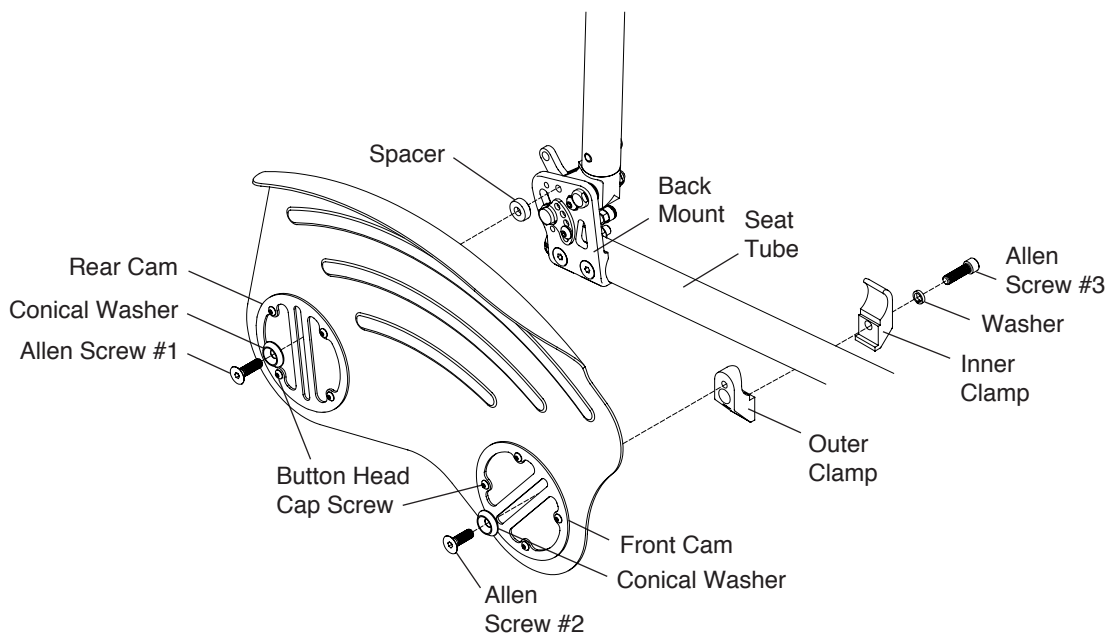

Adjusting

Tools Needed:

- 5/64" Allen Wrench
- 5/32" Allen Wrench

1. Using the 5/32" Allen wrench, loosen but do not remove Allen screw #1. See Figure 6-8.
2. Loosen, but do not remove Allen screw #2 using the 5/32" Allen wrench.
3. Adjust the side guard to the desired position.
4. Securely tighten the two Allen screws.

Note: If you are unable to achieve the desired position, follow the instructions given under "Mounting" on page 6-6, Steps 4 through 8.

⚠ WARNING

The threads on the Button Head Cap screws and Allen screws #1 and #2 have been treated with Vibra-TITE® VC-3, a locking and sealing coating, to reduce the possibility that they will become loose. You should be able to adjust the cams and/or sideguards approximately four times without reapplying the coating to these screws. If you repeatedly adjust the cams or remove the sideguard, TiLite requires that you reapply Vibra-TITE® VC-3 after every fourth adjustment. *If you ignore this Warning, you could fall, tip over or lose control of the wheelchair and seriously injure yourself or others or damage the wheelchair.*

CHAPTER 7: BACK UPHOLSTERY, SEAT UPHOLSTERY AND SEAT CUSHIONS

Velcro®-Style Adjustable Back Upholstery

Note: When adjusting the tension of the back upholstery, DO NOT apply so much tension that the backrest tubes are pulled out of vertical. If this occurs, you may cause the chair to “track” improperly or to develop a “floater.”

Adjusting the Tension

1. Lift the back flap to expose the backrest ears. See Figure 7-1.
2. Completely detach the two backrest ears from the padded back, but do not remove them from the backrest.
3. Adjust to the desired tautness. The closer together the two backrest ears, the more taut the padded back will be. The farther apart the two backrest ears, the looser the padded back will be. Tighter back upholstery will increase the stability and maintain normal maneuverability of the chair because the user is pushed forward slightly. Looser back upholstery will increase maneuverability, but will make the chair more prone to tip over backward because additional weight is being distributed behind the rear wheels.
4. Align the top of the padded back with the two backrest ears to ensure that the top of the back upholstery is even with the top of the backrest.
5. If desired adjust the tension of the strap(s).
6. Securely attach the padded back to the backrest ears using the Velcro®-style material and lower the back flap back into position in front of the rigidizer bar.

Figure 7-1
Adjusting Back Upholstery

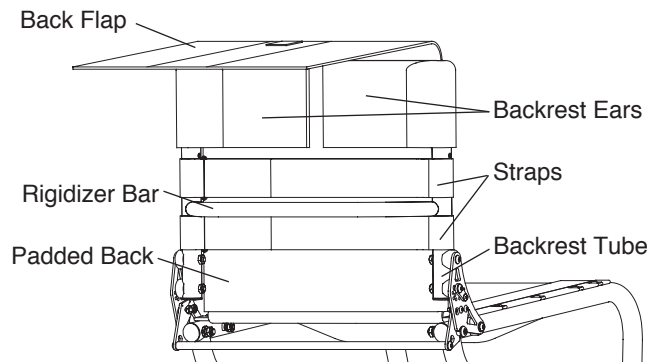

Replacing

1. Lift the back flap to expose the backrest ears. See Figure 7-2.
2. Completely detach the two backrest ears and strap(s) from the padded back and remove them from the backrest.

Note: If your chair has Integrated or Fold-Down Push Handles, you will need to remove the bolts that secure the backrest ears to the backrest (using a 1/8" Allen wrench) and the bolts that secure the backrest posts inside the backrest (using a 5/32" Allen wrench). See Figure 7-3 and see “Adjusting the Backrest Height (TR and YR Series 2)” on pages 4-5 through 4-8 or “Adjusting the Backrest Height (TR Series 3)” on pages 4-8 and 4-9.

3. Remove the seat cushion.
4. Detach the bottom flap from the seat upholstery.
5. Attach bottom flap of the new back upholstery to seat upholstery.
6. Install the two new backrest ears on the backrest.
7. Adjust to the desired tautness. See “Adjusting the Tension” on page 7-1.
8. Align the top of the padded back with the two backrest ears to ensure that the top of the back upholstery is even with the top of the backrest.
9. Reinstall the strap(s) and adjust to the desired tautness.
10. Securely attach the padded back to the backrest ears and lower the back flap back into position in front of the rigidizer bar.
11. Replace the seat cushion.

CHAPTER 7: BACK UPHOLSTERY, SEAT UPHOLSTERY AND SEAT CUSHIONS

Figure 7-2
Replacing Back Upholstery

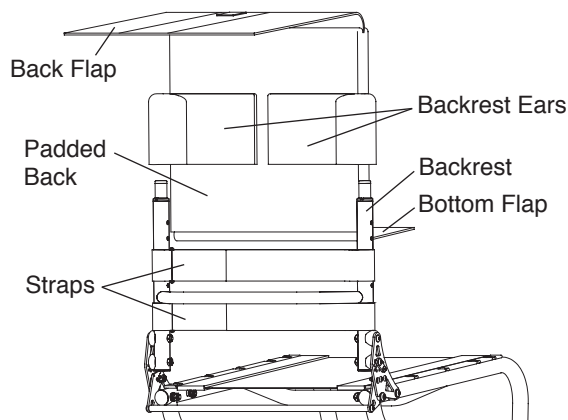
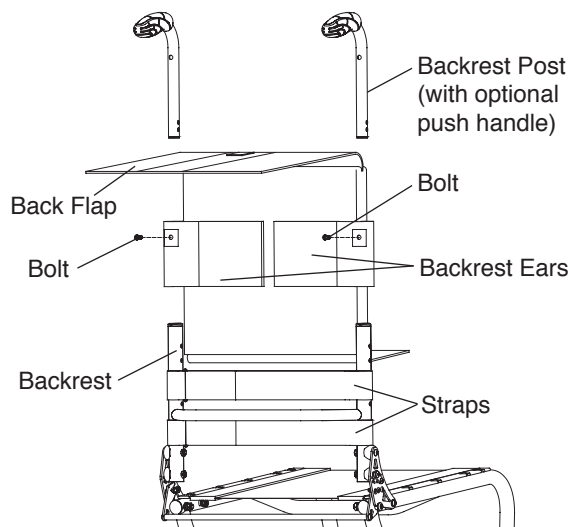

Figure 7-3
Adjusting Back Upholstery with Push Handles



Tension Adjustable by Straps Back Upholstery

Note: When adjusting the tension of the back upholstery, DO NOT apply so much tension that the backrest tubes are pulled out of vertical. If this occurs, you may cause the chair to “track” improperly or to develop a “floater.”

Adjusting the Tension

1. Lift the back flap to expose the backrest ears. See Figure 7-4.
2. Completely detach the padded back from the backrest ears. Do not remove the backrest ears from the backrest.
3. Adjust to the desired tautness by loosening the ear straps and then pulling on the loose end to pull the backrest ears closer together. Tighter back upholstery will increase the stability and maintain normal maneuverability of the chair because the user is pushed forward slightly. Looser back upholstery will increase maneuverability, but will make the chair more prone to tip over backward because additional weight is being distributed onto the rear wheels.
4. Align the top of the padded back with the two backrest ears.
5. If desired, adjust the tension on the strap(s).
6. Securely attach the padded back to the backrest ears and lower the back flap back into position in front of the rigidizer bar.

Figure 7-4
Adjusting Tension Adjustable Back Upholstery

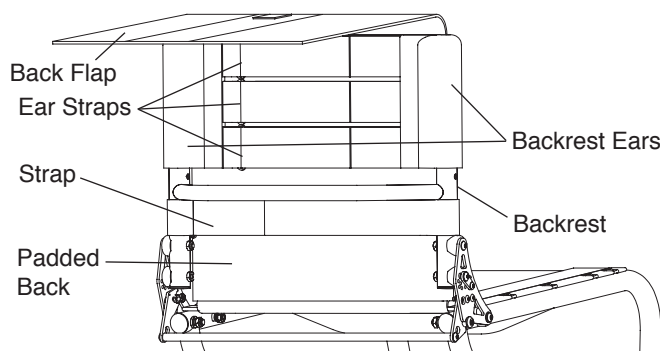

CHAPTER 7: BACK UPHOLSTERY, SEAT UPHOLSTERY AND SEAT CUSHIONS

Replacing

1. Lift the back flap to expose the backrest ears. See Figure 7-5.
2. Completely detach the backrest ears and the strap(s) from the padded back and remove them from the backrest.

Note: If your chair has Integrated or Fold-Down Push Handles, you will need to remove the bolts that secure the backrest ears to the backrest (using a 1/8" Allen wrench) and the bolts that secure the backrest posts inside the backrest (using a 5/32" Allen Wrench). See Figure 7-3 and see "Adjusting the Backrest Height (TR and YR Series 2)" on pages 4-5 through 4-8 or "Adjusting the Backrest Height (TR Series 3)" on pages 4-8 and 4-9.

3. Remove the seat cushion.
4. Detach the bottom flap from the seat upholstery at the underside of the seat upholstery.
5. Attach the bottom flap of the new back upholstery to the seat upholstery at the underside of the seat upholstery
6. Install the new backrest ears on the backrest.
7. Adjust to the desired tautness. See "Adjusting the Tension" on page 7-2.
8. Align the top of the padded back with the backrest ears.
9. Reinstall the strap(s) and adjust to the desired tautness.
10. Securely attach the padded back to the backrest ears and lower the back flap back into position in front of the rigidizer bar.
11. Replace the seat cushion.

Figure 7-5
Adjusting Tension Adjustable By Strap Back Upholstery

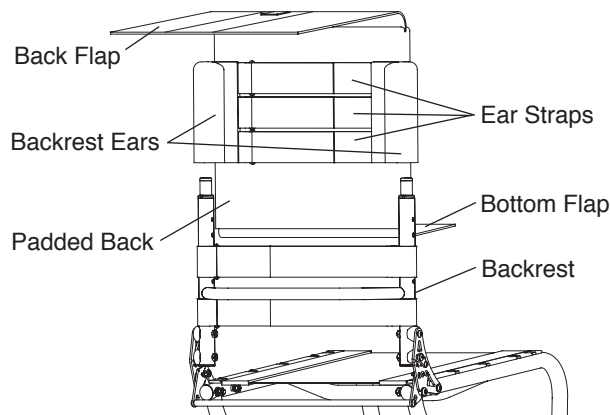

Corbac® Adjustable Contour Back Support

For information regarding the use and adjustment of the Corbac® Adjustable Contour Back Support, consult the owner's manual provided by the manufacturer, Ride Designs.

Tension Adjustable By Straps Seat Sling Upholstery

⚠ WARNING

Do not make the tension of the seat sling upholstery so loose that it does not properly support your weight. You must never permit the sling to become so loose that your weight is borne by the crosstube below the seat sling. See Figure 7-6. *If you ignore this Warning, you may develop pressure sores, which can be a life-threatening medical complication.*

Adjusting the Tension

1. Remove the seat cushion and anti-tips (if applicable).
2. Detach the back upholstery from the seat upholstery (see "Velcro®-Style Adjustable Back Upholstery" on page 7-1 or "Tension Adjustable by Straps Back Upholstery" on pages 7-2 and 7-3).
3. Carefully tip the chair back until it is resting on its rear wheels and the backrest.
4. Detach one tension adjustable strap, adjust to the desired tension and refasten the strap. See Figure 7-6.

CHAPTER 7: BACK UPHOLSTERY, SEAT UPHOLSTERY AND SEAT CUSHIONS

5. Repeat Step 4 for each succeeding tension adjustable strap until you have achieved the desired tension in each strap.
6. Place the chair onto all four wheels.
7. Reattach the back upholstery to the seat upholstery and replace the seat cushion and anti-tips (if applicable).

Figure 7-6
Adjusting/Replacing Tension Adjustable Seat Sling

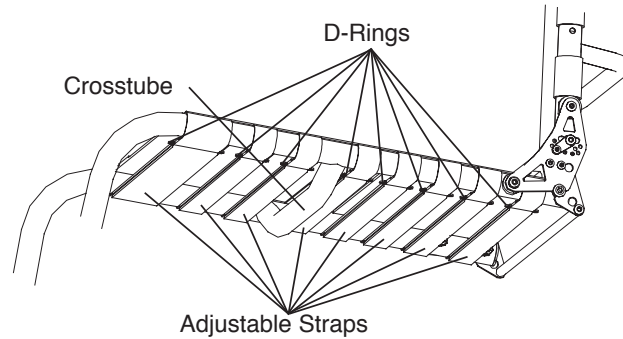

Replacing the Upholstery

1. Remove the seat cushion and anti-tips (if applicable).
2. Detach the back upholstery from the seat upholstery (see “Velcro®-Style Adjustable Back Upholstery” on page 7-1 or “Tension Adjustable by Straps Back Upholstery” on pages 7-2 and 7-3).
3. Carefully tip the chair back until it is resting on its rear wheels and the backrest.
4. Detach all tension adjustable straps that secure the seat upholstery to the frame.
5. Remove the existing seat upholstery.
6. Install the new seat upholstery making sure the straps hang over the left side of the frame (the left side if you were sitting in the chair). See Figure 7-6.
7. Slip the tension adjustable straps through the D-rings on the opposite side of the upholstery under the seat tube.
8. Adjust the seat sling to the desired tension and fasten the tension adjustable straps.
9. Place the chair onto all four wheels.
10. Reattach the back upholstery to the seat upholstery and replace the seat cushion and anti-tips (if applicable).

Bolt-On Seat Sling

⚠ WARNING

Do not make the tension of the seat sling upholstery so loose that it does not properly support your weight. You must never permit the sling to become so loose that your weight is borne by the crosstube below the seat sling. See Figure 7-7. *If you ignore this Warning, you may develop pressure sores, which can be a life-threatening medical complication.*

Adjusting the Tension

Tools required:

- 1/8" Allen Wrench

1. Remove the seat cushion.
2. Detach the back upholstery from the seat upholstery (see “Velcro®-Style Adjustable Back Upholstery” on page 7-1 or “Tension Adjustable by Straps Back Upholstery” on pages 7-2 and 7-3).
3. Loosen, but do not remove, the Allen screws on the side of the seat upholstery where the adjustment flap is located on the underside of the seat upholstery. See Figure 7-7.
4. Detach the adjustment flap, adjust the seat upholstery to the desired tension, and re-secure the adjustment using the Velcro®-style material.
5. Retighten the Allen screws that attach the seat upholstery to the frame.
6. Reattach the back upholstery to the seat upholstery and replace the seat cushion.

CHAPTER 7: BACK UPHOLSTERY, SEAT UPHOLSTERY AND SEAT CUSHIONS

Figure 7-7
Adjusting/Replacing Bolt-On Seat Sling

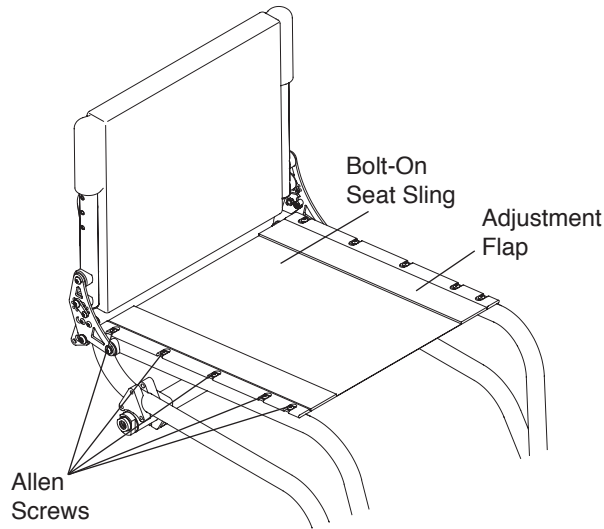

Replacing the Upholstery

Tools required:

- 1/8" Allen Wrench

1. Remove the seat cushion.
2. Detach the back upholstery from the seat upholstery (see "Velcro®-Style Adjustable Back Upholstery" on page 7-1 or "Tension Adjustable by Straps Back Upholstery" on pages 7-2 and 7-3).
3. Remove all bolts that attach the seat upholstery to the chair frame. See Figure 7-7.
4. Remove the Bolt-On Seat Sling.
5. If your replacement upholstery included new aluminum seat rails, proceed to Step 6. If not, remove the aluminum seat rails from the old upholstery and insert them into the new upholstery.
6. Place the new seat upholstery on the frame and align the fastening holes in the upholstery and aluminum seat rails with the holes in the seat tubes of the frame.
7. Loosely install all the bolts on the side of the seat sling where the adjustment flap is located.
8. Install all the bolts on the opposite side of the seat sling and securely tighten.
9. Detach the adjustment flap and adjust the seat upholstery to the desired tension.
10. Fully tighten the bolts that attach the seat upholstery to the frame.
11. Reattach the bottom of the back upholstery to the seat upholstery and replace the seat cushion.

Seat Cushions

Replacing the Foam Insert in the TiLite Seat Cushion

1. Lift up and remove the existing seat cushion from the seat upholstery.
2. Unzip the seat cushion cover and remove the foam insert.
3. Insert the new foam insert into the seat cushion cover.
4. Close the seat cushion cover and replace on the chair.

For seat cushions manufactured by manufacturers other than TiLite (e.g. Corbee, StimuLite, Roho, Varilite, etc.), consult the owner's manual provided by the applicable manufacturer.

Velcro®-Style Adjustable Seat Belt

⚠ WARNING

Installation of the Velcro®-Style Seat Belt must be performed by an authorized TiLite dealer or qualified technician. *If you ignore this Warning, serious injury may result.*

CHAPTER 7: BACK UPHOLSTERY, SEAT UPHOLSTERY AND SEAT CUSHIONS

⚠ WARNING

The Velcro®-Style Seat Belt must be worn tightly fitted across the lower pelvis or thighs at all times. A loose belt can allow the user to slip down and create a risk of strangulation. Have your seating specialist demonstrate its proper adjustment and use. See Figures 7-8 to 7-11. Accidental release of the Velcro®-Style Seat Belt can allow the user to slip down or fall from the wheelchair. If the user's movements or cognitive abilities could lead to accidental release, a caregiver must be present at all times during its use. Ensure that all caregivers know how to unfasten the product. Failure to do so may delay release in an emergency. As with any new seating support, the Velcro®-Style Seat Belt may change the way a person sits. Users must continue to practice regular pressure relief activities and skin integrity checks, not only where this product contacts the user, but also in primary pressure-bearing areas such as the sacrum, legs, and buttocks. If increased skin redness or irritation occurs, discontinue use and consult your physician or seating specialist. Failure to do so may result in serious injury, such as pressure ulcers. *If you ignore any of these Warnings, you may incur serious or life-threatening injuries.*

⚠ WARNING

A wheelchair user must never use the wheelchair which has seat belts installed without proper securement of the seat belt around the user. Should the seat belt not be properly secured, the belt may become entangled in the wheels or an external obstacle which may lead to the wheelchair coming to a sudden stop causing the user to fall out of the wheelchair. *If you ignore this Warning, you may incur serious or life-threatening injuries.*

Installation

The seat belt will be installed as shown in Figures 7-8 and 7-10.

Figure 7-8
TR/YR Series 2 Velcro®-Style Seat Belt

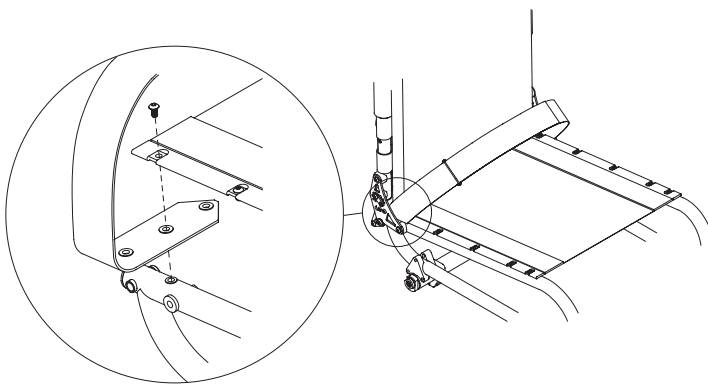
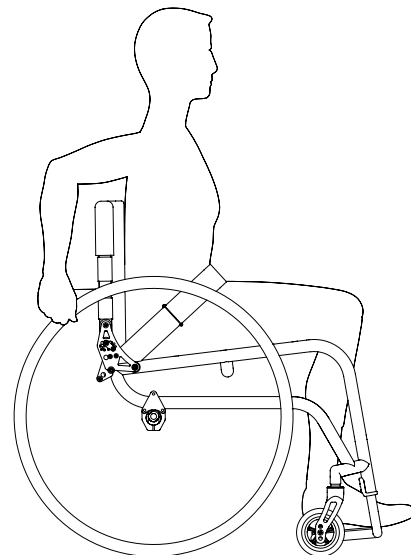

Figure 7-9
TR/YR Series 2 Proper Belt Position



CHAPTER 7: BACK UPHOLSTERY, SEAT UPHOLSTERY AND SEAT CUSHIONS

Figure 7-10
TR Series 3 Velcro®-Style Seat Belt with D-Ring

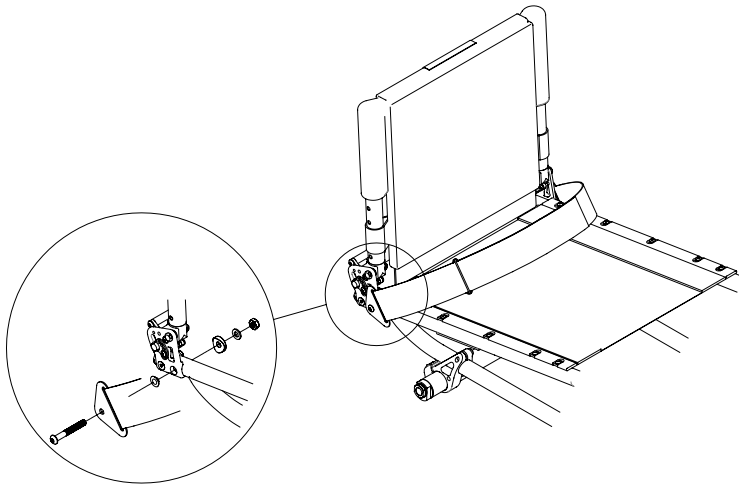
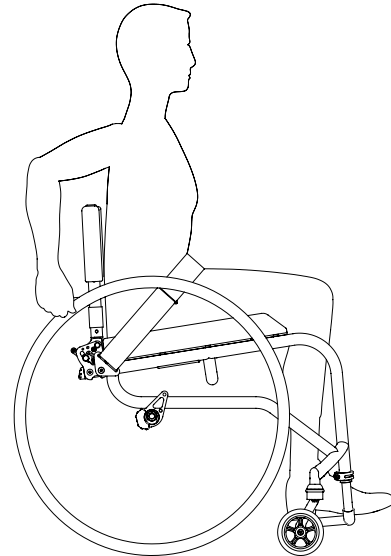

Figure 7-11
TR Series 3 Proper Belt Position for Belt with D-Ring



Adjustment

When the belt is properly adjusted and tightened, it should fit snug so that the user's pelvis is secure. See Figures 7-9 and 7-11. If length adjustment is necessary to achieve a good fit or to remove the belt for cleaning, this can be done using the belt end fittings.

Safety Check

When properly positioned in wheelchair, the wheelchair user should lean forward and side to side to check the fit. Check for:

1. Normal operation of adjustment straps.
2. Comfort: look for areas of irritation.
3. Position: if too high or too low, adjust anchor points.
4. Interference with other devices: relocate anchor points as necessary.
5. Move chair through full range of motion, including folding, and rolling. Check for any interference.

Maintenance

Check periodically for signs of wear in the stitching and webbing. If significant wear is found, contact your supplier for qualified repair or replacement by TiLite.

CHAPTER 8: AXLE PLATES AND CAMBER PLUGS (CENTER OF GRAVITY; REAR SEAT HEIGHT)

All TiLite TR and YR wheelchairs are equipped with a camber tube (unless you have selected the optional Adjustable Camber System). By adjusting the position of the camber tube, you can adjust the center of gravity of your chair. This Chapter explains the various adjustments that are possible. The same adjustment will apply whether you have an aluminum, titanium or carbon fiber camber tube. If your camber is 12°, 15° or 18° and you need to remove the camber tube, you will need to remove the axle sleeve to allow the camber tube to slide out of the clamp or mount, see “Adjusting Rear Wheel Spacing” on page 12-3.

⚠ WARNING

Any changes to the position of the camber tube will affect the stability of the chair. Use extreme caution when using a new camber tube position as the new position may make the chair more prone to tip over. *If you ignore this Warning, your chair may not perform properly, which in turn, may cause you to fall, tip over or lose control of the chair and seriously injure yourself or others or damage the chair.*

⚠ WARNING

Whenever you adjust the position of the camber tube (either to adjust the rear seat height or the center of gravity), it may be necessary to adjust the toe-in/toe out of the rear wheels. See “Adjusting Toe-In/Toe-Out” on pages 8-3 and 8-4. In addition, whenever you adjust the position of the camber tube or when you adjust the toe-in *If you ignore this Warning, your chair may not perform properly, which, in turn, may cause you to fall, tip over or lose control of the chair and seriously injure yourself or others or damage the chair.*

Note: It is recommended that you remove the rear wheels and turn the chair upside down before attempting to make any adjustments described in this Chapter. A padded surface will help protect the frame’s finish.

Standard Camber Mounts

Adjusting the Center of Gravity

(TR and YR Series 2)

Tools Needed:

- 3/16” Allen Wrench
- Ruler

1. Remove the rear wheels.
2. Loosen, but do not remove, the six Allen screws (three on each side of the chair) that secure the camber clamps and camber tube mounts to the frame. See Figure 8-1.
3. Simultaneously slide both camber tube clamping assemblies forward and rearward along the frame until they are positioned in the desired location. Use a ruler to ensure both camber tube clamping assemblies are the same distance from the rear of the frame (measured from the rear of the frame to the top of the clamping assembly). See Figure 8-2.
4. Securely tighten the six Allen screws that secure the axle clamps and camber tube mounts to the frame.
5. Reinstall the rear wheels.
6. Check the toe-in/toe-out and adjust as needed.

CHAPTER 8: AXLE PLATES AND CAMBER PLUGS (CENTER OF GRAVITY; REAR SEAT HEIGHT)

Figure 8-1
Adjusting the Center of Gravity

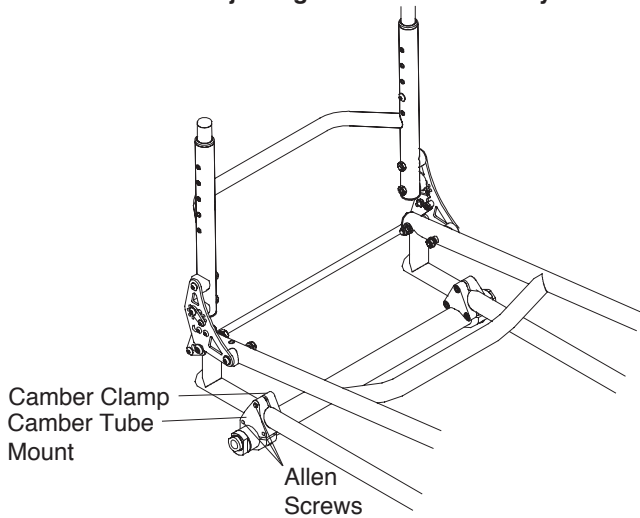
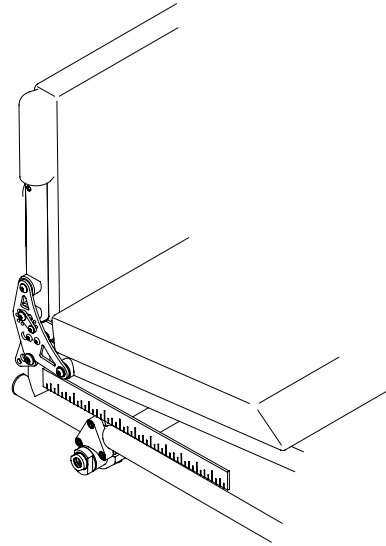

Figure 8-2
Adjusting the Center of Gravity



Replacing the Camber Tube (TR and YR Series 2)

Tools Needed:

- 3/16" Allen Wrench
- Ruler

1. Remove the rear wheels.
2. Loosen, but do not remove, the Allen screw that secures the camber tube to each camber tube mount. See Figure 8-3.
3. Remove the camber tube.

Note: If your camber is 12°, 15° or 18°, you will need to remove the axle sleeve to allow the camber tube to slide out of the clamp or mount, see “Adjusting Rear Wheel Spacing” on page 12-3.

4. Install the new camber tube, making sure the distance from the outside edge of the camber tube mount to the end of the camber tube is identical on each side of the chair.
5. Make sure that the camber plug flats are perpendicular to the ground and that the camber is oriented properly.
6. Securely tighten both Allen screws.
7. Reinstall the rear wheels.
8. Check the toe-in/toe-out and adjust as needed.

Figure 8-3
Replacing the Camber Tube

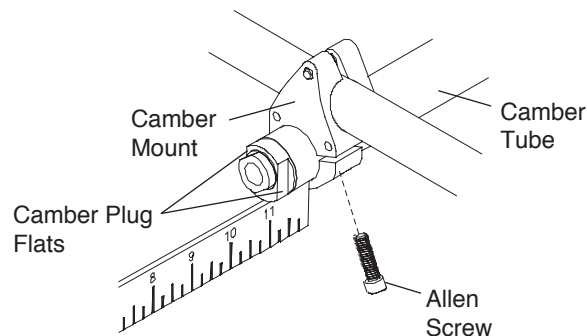

CHAPTER 8: AXLE PLATES AND CAMBER PLUGS (CENTER OF GRAVITY; REAR SEAT HEIGHT)

Adjusting the Center of Gravity (TR Series 3)

Tools Needed:

- 3/16" Allen Wrench
- Ruler

1. Remove the rear wheels.
2. Loosen, but do not remove, the four Allen screws (two on each side of the chair) that secure the camber mounts and camber mount tops to the frame. See Figure 8-4.
3. Simultaneously slide both camber tube clamping assemblies forward and rearward along the frame until they are positioned in the desired location. Use a ruler to ensure both camber tube clamping assemblies are the same distance from the rear of the frame (measured from the front of the backrest to the center of the camber tube). See Figure 8-5.
4. Securely tighten the four Allen screws that secure the camber mounts and camber mount tops to the frame.
5. Reinstall the rear wheels.
6. Check the toe-in/toe-out and adjust as needed.

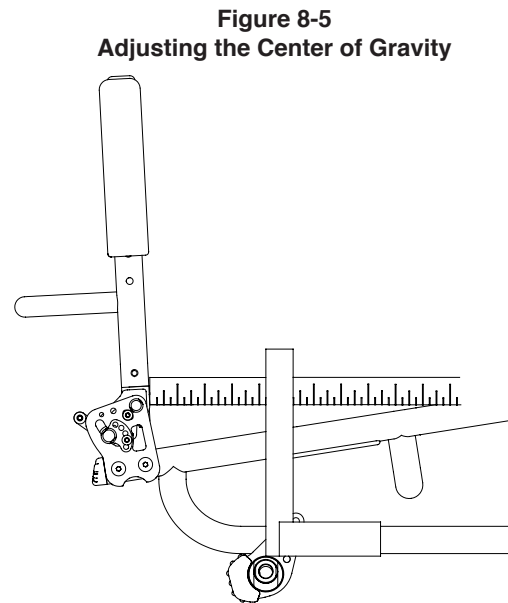
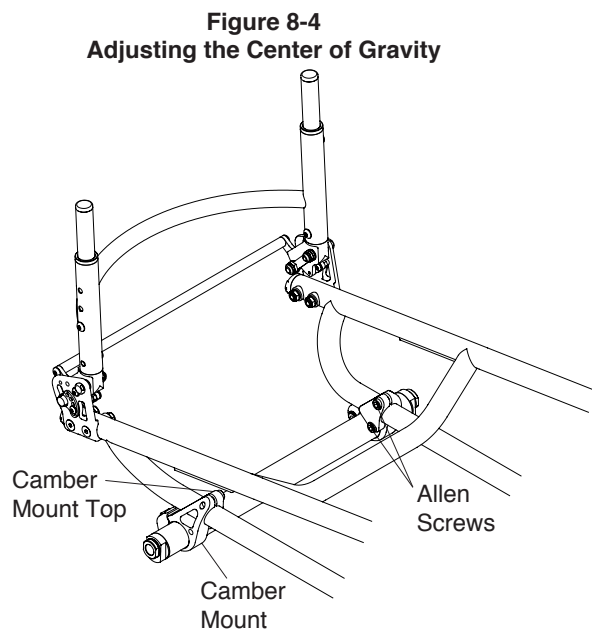

Replacing the Camber Tube (TR Series 3)

Tools Needed:

- 3/16" Allen Wrench
- 5/64" Allen Wrench
- Ruler

1. Remove the rear wheels.
2. Using the 5/64" Allen wrench, remove the camber mount bumper assembly, making note of the order in which the parts are assembled. If your chair has anti-tips, you will not have a bumper assembly.
3. Loosen, but do not remove, the Allen screw that secures the camber tube to each camber mount. See Figure 8-6.
4. Remove the camber tube.

Note: If your camber is 12°, 15° or 18°, you will need to remove the axle sleeve to allow the camber tube to slide out of the clamp or mount, see "Adjusting Rear Wheel Spacing" on page 12-3.

5. Install the new camber tube, making sure the distance from the outside edge of the camber mount to the end of the camber tube is identical on each side of the chair.

CHAPTER 8: AXLE PLATES AND CAMBER PLUGS (CENTER OF GRAVITY; REAR SEAT HEIGHT)

6. Make sure that the camber plug flats are perpendicular to the ground and that the camber is oriented properly.
7. Securely tighten both Allen screws.
8. Reinstall the bumper assembly.
9. Reinstall the rear wheels.
10. Check the toe-in/toe-out and adjust as needed and square the casters. See pages 8-5 and 8-6.

Figure 8-6
Replacing the Camber Tube

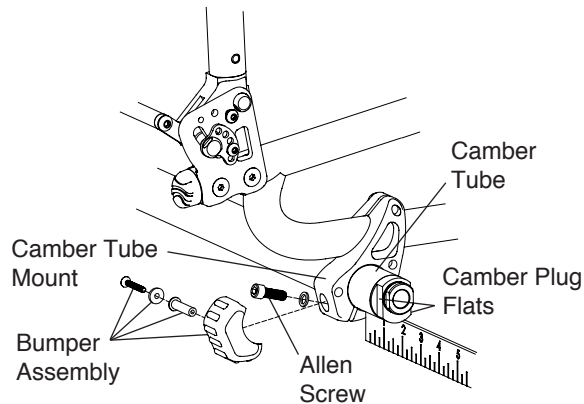

Frog Legs® Suspension

Adjusting the Center of Gravity

Tools Needed:

- 7/16" Open End Wrench
- Ruler

1. Remove the rear wheels.
2. Loosen but do not remove the four Hex bolts (two on each side of the chair) that secure the Frog Legs® Suspension to the frame. See Figure 8-7.
3. Simultaneously slide both Frog Legs® Suspensions forward or rearward along the frame until they are positioned in the desired location. Use a ruler to ensure both suspensions are the same distance from the back post (measured from the back to the top of the suspension). See Figure 8-7.
4. Securely tighten the four bolts that secure the Frog Legs® Suspension to the frame.
5. Reinstall the rear wheels.
6. Check the toe-in/toe-out and adjust as needed.

Figure 8-7
Frog Legs® Suspension

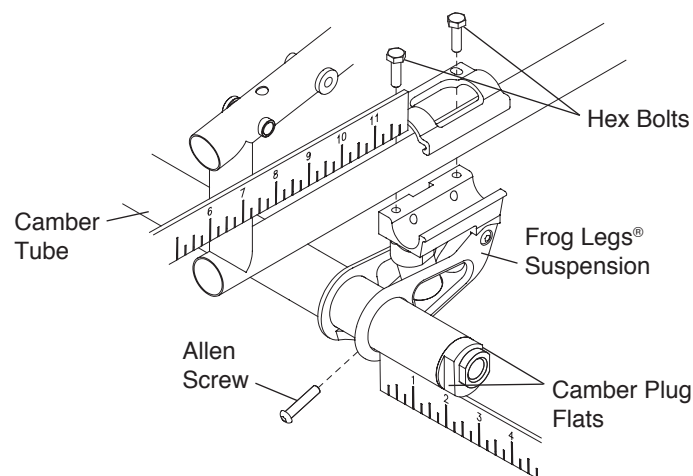

CHAPTER 8: AXLE PLATES AND CAMBER PLUGS (CENTER OF GRAVITY; REAR SEAT HEIGHT)

⚠ WARNING

The threads on the Hex bolts that secure the Frog Legs® Suspension to the frame are treated with Loctite® 242®, a medium strength thread lock. If you loosen any Hex bolt, you **MUST** remove and reapply Loctite® 242® or an equivalent medium strength thread lock. *If you ignore this Warning, your Frog Legs® Suspension could become loose or fall off and you could fall, tip over or lose control of the wheelchair and seriously injure yourself or others or damage the wheelchair.*

Replacing the Camber Tube

Tools Needed:

- 5/32" Allen Wrench

1. Remove the rear wheels.
2. Loosen but do not remove the Allen screw that secures the camber tube to each Frog Legs® Suspension. See Figure 8-7.
3. Remove the camber tube.

Note: If your camber is 12°, 15° or 18°, you will need to remove the axle sleeve to allow the camber tube to slide out of the clamp or mount, see “Adjusting Rear Wheel Spacing” on page 12-3.

4. Install the new camber tube, making sure the distance from the outside edge of the Frog Legs® Suspension to the end of the camber tube is identical on both sides of the chair.
5. Make sure that the camber plug flats are perpendicular to the ground and that the camber is oriented properly (wheel base wider at the bottom than the top).
6. Securely tighten both Allen screws.
7. Reinstall the rear wheels.
8. Check the toe-in/toe-out and adjust as needed.

Adjusting Toe-In/Toe-Out

Tools Needed:

- 3/16" Allen Wrench
- 7/8" Open End Wrench
- Ruler or Tape Measure

Note: Adjusting toe-in/toe-out does not apply to chairs with 0° camber; however, it is still necessary to make sure that the camber plug flats are perpendicular to the ground and the axle sleeve is located at the uppermost part of the plug..

1. Make sure the distance from the end of the camber tube to the camber clamp is identical on both sides of the chair. See Figure 8-8.
2. Make sure the rear wheels are properly inflated.
3. Place the chair on all four wheels with the casters trailing toward the rear of the frame. See Figure 8-9.

Figure 8-8
Adjusting the Toe-In/Toe-Out

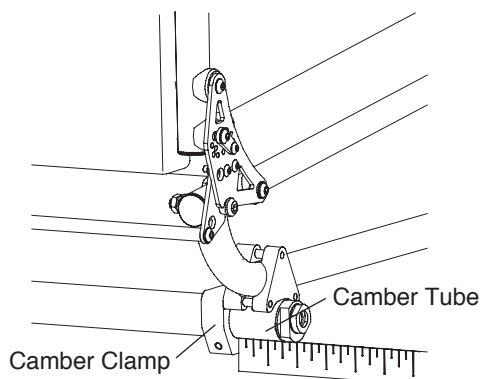
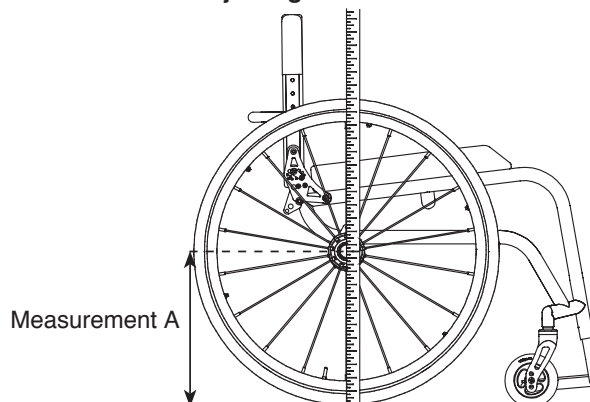

Figure 8-9
Adjusting the Toe-In/Toe-Out



CHAPTER 8: AXLE PLATES AND CAMBER PLUGS (CENTER OF GRAVITY; REAR SEAT HEIGHT)

4. Measure from the floor to the center of the axle ("Measurement A"). Be sure the tape measure/ruler is perpendicular to the floor.
5. Block the wheels with a heavy object so the chair can not roll forward or backward (do not use the wheel locks as this may affect the toe-in/toe-out adjustment).
6. Measuring from the floor at the rear of each tire, mark the tire (with a felt tip pen) at the same height as Measurement A.
7. Measuring from the floor at the front of each tire, mark the tire (with a felt tip pen) at the same height as Measurement A.
8. Measure the distance between the left and right tires at the rear reference marks made in Step 6. See Figure 8-10.
9. Measure the distance between the left and right tires at the front reference marks made in Step 7.
10. If the measurements in Steps 8 and 9 are the same (within 1/8"), no toeing adjustment is needed, and you may skip to Step 13. If not, proceed to Step 11.
11. Loosen the Allen screw in each camber clamp that secures the camber tube in place.
12. If the measurement in Step 9 is less than the measurement in Step 8, rotate the camber tube using the 7/8" Open End wrench rearward to toe-out the rear wheels. If the measurement in Step 9 is greater than the measurement in Step 8, rotate the camber tube using the 7/8" Open End wrench forward to toe-in the rear wheels. Continue adjusting the camber tube until these two measurements are equal. See Figure 8-11.
13. Securely tighten the Allen screws in the camber tube clamp.

Figure 8-10
Adjusting the Toe-In/Toe-Out

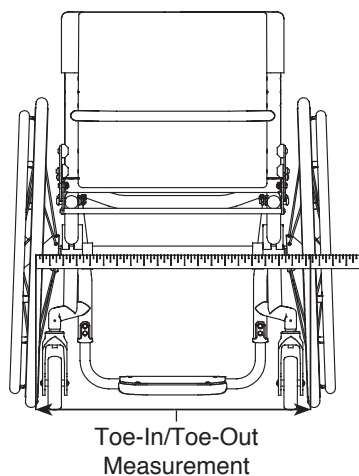
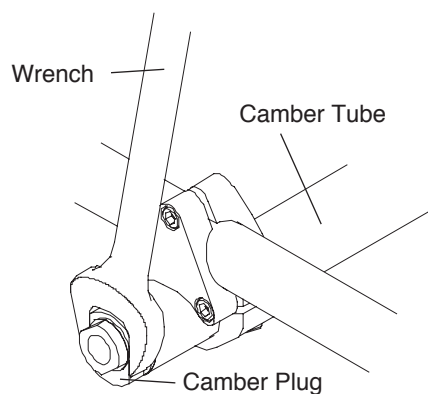

Figure 8-11
Adjusting the Toe-In/Toe-Out



Adjustable Camber System

Adjusting the Skewer Handle Tension

1. Release the handle on the skewer to the unlocked position. See Figure 8-12.
2. Loosen or tighten the Allen screw on the end of the skewer.
3. Return the handle of the skewer to the locked position.

CHAPTER 8: AXLE PLATES AND CAMBER PLUGS (CENTER OF GRAVITY; REAR SEAT HEIGHT)

Figure 8-12
Adjusting the Toe-In/Toe-Out

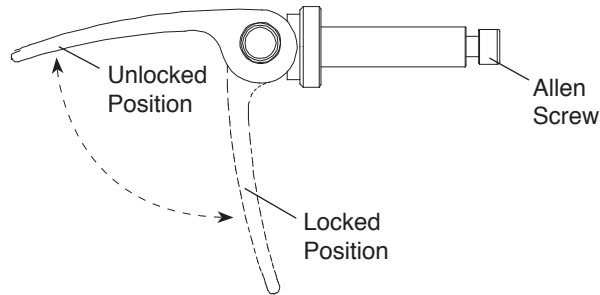

Changing the Camber

Tools Needed:

- 5/32" Allen Wrench

1. Remove the rear wheels and turn your chair upside down.
2. Unlock all four skewers. See Figure 8-13.
3. Remove the four Allen screws and the two retaining plates from the rear side of the adjustable camber mounting plate.
4. Remove all four skewers from adjustable camber mounting plate.
5. Using Figure 8-14, determine the placement of the retaining plate and skewers that will achieve your desired camber.
6. Reposition the axle sleeve mounts to the desired camber position, making sure to align the holes in the axle sleeve mount with the holes on the front and rear adjustable camber mounting plates. See Figure 8-14.
7. Reinsert the skewers through the adjustable camber mounting plates and the axle sleeve mounts.
8. Reinstall the retaining plates and Allen screws at the rear side of the adjustable camber mounting.
9. Return the handles of all four skewers to the locked position.
10. Reinstall the rear wheels and turn the chair right side up.
11. Check the toe-in/toe-out and adjust as needed.

Adjusting Rear Wheel Spacing

Tools Needed:

- 3/16" Allen Wrench
- Ruler

⚠ WARNING

Do not extend the camber plug more than 1-1/2" out of the axle sleeve mount. If more than 1-1/2" of the camber plug is outside of the axle sleeve mount, the camber plug could disengage from the axle sleeve mount while you are using the chair. *If you ignore this Warning, you may fall, tip over or lose control of the wheelchair and seriously injure yourself or others or damage the wheelchair.*

⚠ WARNING

Do not use rear wheel spacers on an adjustable camber plug. *If you ignore this Warning, you may fall, tip over or lose control of the wheelchair and seriously injure yourself or others or damage the wheelchair.*

1. Remove the rear wheels.
2. Loosen, but do not remove, the two Allen screws located on the axle sleeve mount on each side of your chair. Only loosen the screws enough to permit the camber plug to slide in and out of the axle sleeve mount. See Figure 8-14.

CHAPTER 8: AXLE PLATES AND CAMBER PLUGS (CENTER OF GRAVITY; REAR SEAT HEIGHT)

Figure 8-13
Adjustable Camber System

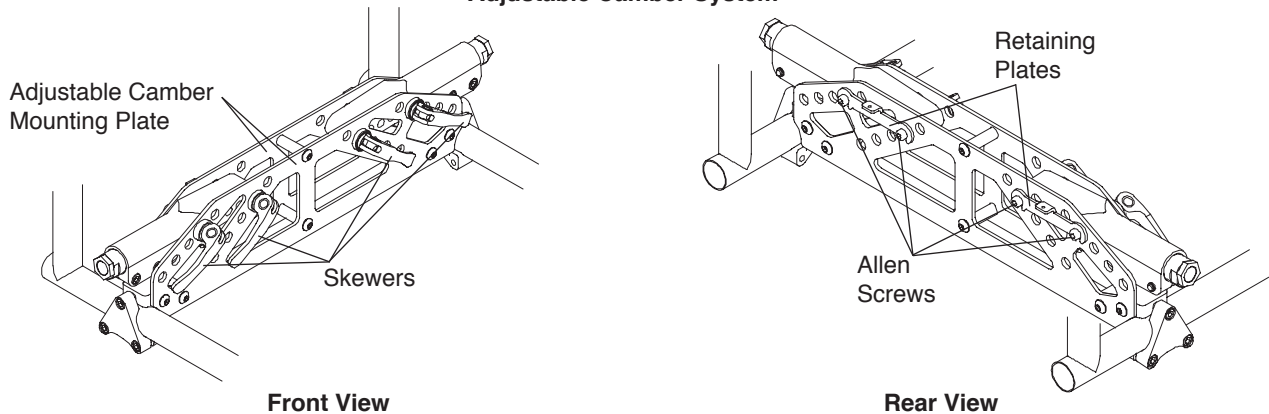
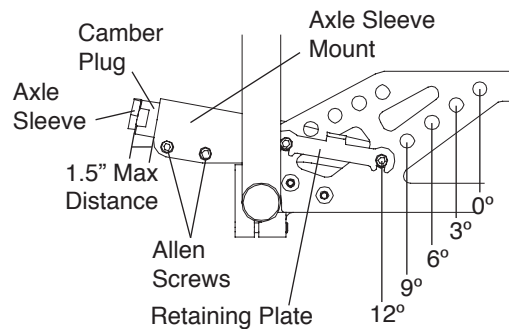

Figure 8-14
Camber Setting



3. Slide the camber plugs in or out of the axle sleeve mounts to increase or decrease the rear wheel spacing. Make sure the distance from the end of the axle sleeve to the end of the axle sleeve mount is the same on both sides of the chair.
4. Securely tighten all four Allen screws in the axle sleeve mounts.
5. Reinstall the rear wheels.
6. Check the toe-in/toe-out and adjust as needed.

Adjusting Toe-In/Toe-Out

Tools Needed:

- 3/16" Allen Wrench
- Ruler or Tape Measure

1. Make sure both rear wheels are equally spaced. See "Adjusting Rear Wheel Spacing" on page 8-7.
2. Make sure the rear wheels are properly inflated.
3. Place the chair on all four wheels with the casters trailing toward the rear of the frame. See Figure 8-15.
4. Measure from the floor to the center of the axle ("Measurement A"). Be sure the tape measure/ruler is perpendicular to the floor. See Figure 8-15.
5. Block the wheels with a heavy object so the chair can not roll forward or backward (do not use the wheel locks as this may affect the toe-in/toe-out adjustment).
6. Measuring from the floor at the rear of each tire, mark the tire (with a felt tip pen) at the same height as Measurement A.
7. Measuring from the floor at the front of each tire, mark the tire (with a felt tip pen) at the same height as Measurement A.
8. Measure the distance between the left and right tires at the rear reference marks made in Step 6. See Figure 8-16.
9. Measure the distance between the left and right tires at the front reference marks made in Step 7.

CHAPTER 8: AXLE PLATES AND CAMBER PLUGS (CENTER OF GRAVITY; REAR SEAT HEIGHT)

10. If the measurements in Steps 8 and 9 are the same (within 1/8"), no toeing adjustment is needed, and you may skip to Step 13. If not, proceed to Step 11.
11. Loosen the two Allen screws in each axle sleeve mount that secure the camber plug in place. See Figure 8-14.
12. If the measurement in Step 9 is less than the measurement in Step 8, rotate both axle sleeves equally rearward to toe-out the rear wheels. If the measurement in Step 9 is greater than the measurement in Step 8, rotate both axle sleeves equally forward to toe-in the wheels. Continue adjusting the axle sleeves until these two measurements are equal.
13. Measure the distance from the seat tube to the inside of the tire at the front of each tire on both sides of the frame ("Measurement B"). See Figure 8-17.
14. If Measurement B is the same on both sides of the chair, proceed to Step 17.
15. If Measurement B is not the same on both sides of the chair, you will need to rotate the camber plugs in the axle sleeve mounts as necessary to make sure Measurement B is equal on both sides of the chair. Make sure when you rotate the camber plugs, you do not affect the rear wheel spacing. See "Adjusting Rear Wheel Spacing" on page 8-7.
16. After adjusting the camber plugs in Step 15, it will be necessary to recheck the toe-in/toe-out. See Steps 6 through 10 above.
17. Securely tighten the Allen screws in the axle sleeve mounts. See Figure 8-14.

Figure 8-15
Adjusting Toe-In/Toe-Out

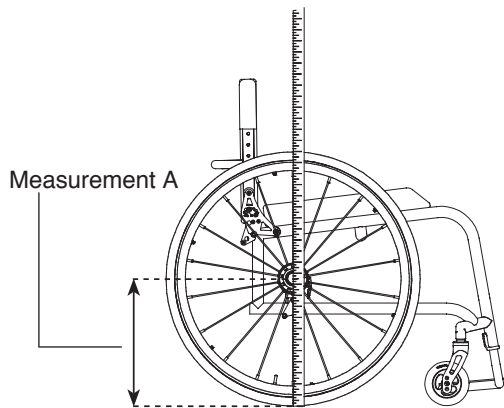

Figure 8-16
Adjusting Toe-In/Toe-Out

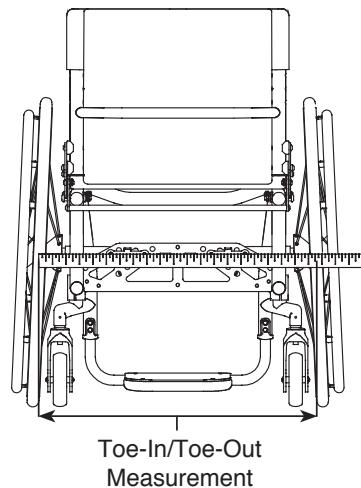
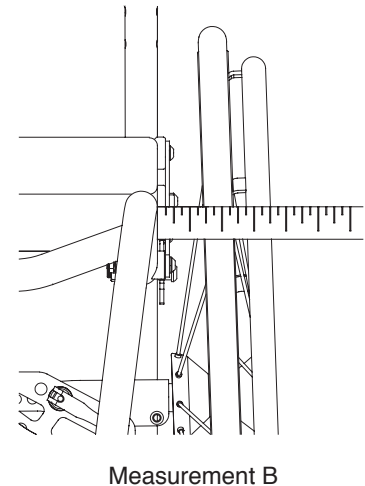

Figure 8-17
Adjusting Toe-In/Toe-Out



CHAPTER 9: AXLES AND AMPUTEE ADAPTERS

⚠ WARNING

Do not attempt any of the procedures in this Chapter when the chair is occupied. *If you ignore this Warning, you may fall, tip over or lose control of the wheelchair and seriously injure yourself or others or damage the wheelchair.*

Stainless and Titanium Quick-Release Axles

Adjusting the Quick-Release Axle

⚠ WARNING

Quick-Release Axles are pre-adjusted to permit minimal “play” in the axle. TiLite recommends that you do not adjust the axle. Improperly adjusting the axle could cause it to malfunction—too much “play” can cause the axle to bend and become stuck in the axle sleeve; too little “play” can prevent the locking balls from engaging fully, causing the wheel to disengage from the chair without warning. TiLite recommends that an authorized TiLite dealer make any adjustments. *If you ignore this Warning, you may fall, tip over or lose control of the wheelchair and seriously injure yourself or others or damage the wheelchair.*

Tools Needed:

- 3/4” Open End Wrench
- 7/16” Open End Wrench

1. Depress the release button and remove the rear wheel and Quick-Release Axle. See Figure 9-1.
2. Remove the axle from the wheel by depressing the release button and sliding the axle through the rear wheel hub.
3. Once removed from the hub, release the release button (the locking balls should be fully extended).
4. Increase or decrease axle “play” by adjusting the locknut while securing the opposite end of the axle using the smaller wrench at the flats at the end of the axle.
5. Depress the release button on the Quick-Release Axle and slide the axle through the rear wheel hub.
6. Depress the release button and reinstall the rear wheel into the axle sleeve.
7. Before riding in the chair, make sure the locking balls have fully secured the wheel in the axle sleeve by pulling on the hub without depressing the release button on the Quick-Release Axle. If the locking balls do not fully engage, repeat these procedures and increase the play (i.e., increase the distance between the locknut and the locking balls) to permit the locking balls to fully engage properly. Also, check to make sure there is not too much play in the axle.

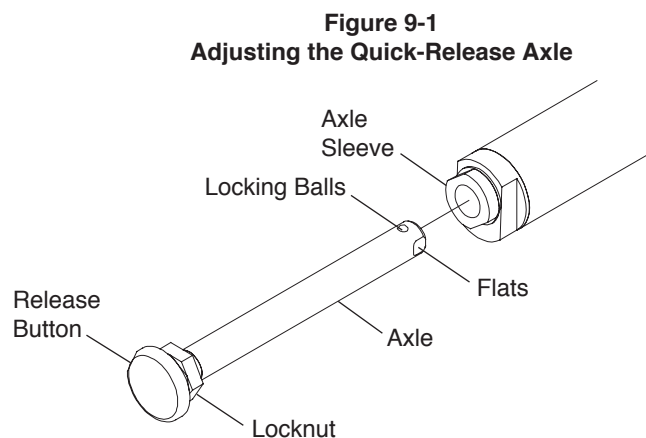

Quad Quick-Release Axles

Adjusting the Quad Quick-Release Handle

⚠ WARNING

Quick release axles are pre-adjusted to permit minimal “play” in the axle. TiLite recommends that you do not adjust the axle. Improperly adjusting the axle could cause it to malfunction—too much “play” can cause the axle to bend and become stuck in the axle sleeve; too little “play” can prevent the locking balls from engaging fully, causing the wheel to disengage from the chair without warning. TiLite recommends that an authorized TiLite dealer make any adjustments. *If you ignore this Warning, you may fall, tip over or lose control of the wheelchair and seriously injure yourself or others or damage the wheelchair.*

CHAPTER 9: AXLES AND AMPUTEE ADAPTERS

If the release handle does not flip back and forth from locked to unlocked properly, or if you cannot fully engage it in the locked position or the unlocked position, the procedure below will permit you to adjust the operation of the handle.

Tools Needed:

- 5/64" Allen Wrench

1. Flip the quick-release handle to the unlocked position and remove the rear wheel and Quick-Release Axle. See Figure 9-2.
2. Flip the quick-release handle to the locked position.
3. To adjust the “play” between the quick-release handle and the release button inside the quick-release nut: (a) loosen Set Screw 2 on the quick-release nut; (b) rotate the quick-release nut clockwise or counter-clockwise on the axle until the release button inside the quad quick-release nut just touches the release handle while it is in the locked position; and (c) tighten Set Screw 2.
4. Adjusting the “play” in the quick-release handle may necessitate an adjustment to the “play” between the collar and the wheel hub. See “Adjusting the Play” on pages 9-2 and 9-3.
5. With the quick-release handle in the unlocked position, reinstall the rear wheel on the chair.
6. Before riding in the chair, make sure the locking balls have fully secured the wheel in the axle sleeve by pulling on the hub with the release handle in the locked position. If the locking balls do not fully engage, repeat these procedures to increase the “play” (i.e., increase the distance between the quick-release nut and the locking balls), to permit the locking balls to fully engage properly. Also, check to make sure there is not too much “play” in the axle. See “Adjusting the Play” on pages 9-2 and 9-3.

Figure 9-2
Quad Quick-Release Axle Adjustment

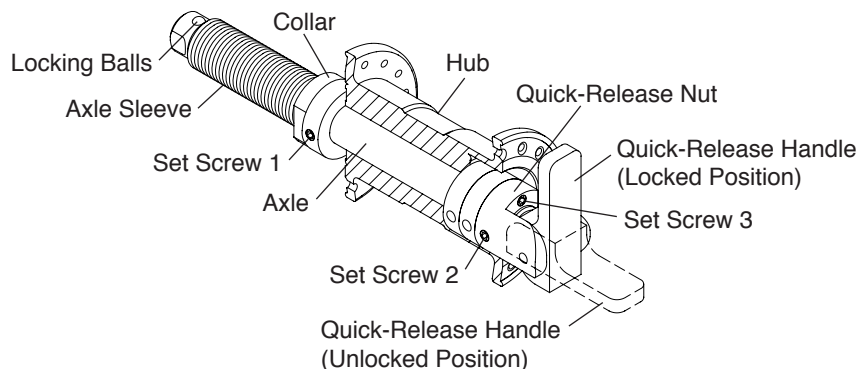

⚠ WARNING

The threads on the set screws on the Quad Quick-Release Axles Assemblies are treated with Loctite® 242®, a medium strength thread lock. If you loosen any set screw, you **MUST** remove and reapply Loctite® 242® or an equivalent medium strength thread lock. *If you ignore this Warning, your rear wheel could become loose or fall off and you could fall, tip over or lose control of the wheelchair and seriously injure yourself or others or damage the wheelchair.*

Adjusting the “Play”

⚠ WARNING

Quick-Release Axles are pre-adjusted to permit minimal “play” in the axle. TiLite recommends that you do not adjust the axle. Improperly adjusting the axle could cause it to malfunction—too much “play” can cause the axle to bend and become stuck in the axle sleeve; too little “play” can prevent the locking balls from engaging fully, causing the wheel to disengage from the chair without warning. TiLite recommends that an authorized TiLite dealer make any adjustments. *If you ignore this Warning, you may fall, tip over or lose control of the wheelchair and seriously injure yourself or others or damage the wheelchair.*

If there is too much “play” in the axle so the wheel is loose when locked into position in the axle sleeve or too little “play” so the locking balls do not properly engage, follow this procedure:

Tools Needed:

- 5/64" Allen Wrench

CHAPTER 9: AXLES AND AMPUTEE ADAPTERS

1. Flip the quick-release handle to the unlocked position and remove the rear wheel and Quick-Release Axle. See Figure 9-2.
2. Adjust Set Screw 3 on the quick-release nut so that no portion of Set Screw 3 is protruding out of the opposite side of the quick release nut (the side adjacent to the wheel hub).
3. Loosen Set Screw 1 on the collar.
4. Replace the wheel on the chair.
5. With the wheel still on the chair and the quad quick-release handle in the locked position so the locking balls are fully engaged, securely tighten Set Screw 1 so the collar is securely on the axle sleeve.
6. With the release handle in the unlocked position, turn Set Screw 3 clockwise to remove any remaining play between the wheel hub and collar.
7. Flip the quad quick-release handle to the locked position and check the “play” in the axle. Make sure the locking balls fully engage and lock the axle into the camber tube. If there is still too much “play” in the axle, repeat the procedure in Step 6. If you have taken too much “play” out of the axle, repeat the procedure in Step 6, but turn Set Screw 3 counterclockwise to add “play” to the axle.
8. Before riding in the chair, check the “play” in wheel and check to make sure the locking balls have fully secured the axle inside the axle sleeve by pulling on the hub with the quad quick-release handle in the locked position. If the locking balls do not properly engage or there is too much “play”, return to Step 1 and repeat this procedure.

⚠ WARNING

The threads on the set screws on the Quad Quick-Release Axle assemblies are treated with Loctite® 242®, a medium strength thread lock. If you loosen any set screw, you **MUST** remove and reapply Loctite® 242® or an equivalent medium strength thread lock. *If you ignore this Warning, your rear wheel could become loose or fall off and you could fall, tip over or lose control of the wheelchair and seriously injure yourself or others or damage the wheelchair.*

Amputee Adapters

Amputee adapters serve to relocate the camber tube behind the rear of the wheelchair. Positioning the camber tube behind the rear of the chair shifts the center of gravity rearward and increases the stability of the chair. See Figure 9-3.

You can adjust the rear seat height and center of gravity, and you can replace the camber tubes, by following the procedures and using the tools in Chapter 8.

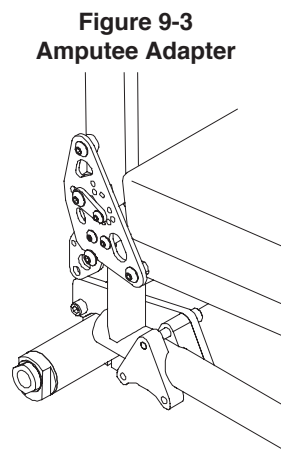

△ WARNING

TiLite recommends that you remove the wheel locks from your chair frame prior to engaging in any contact sport. *If you ignore this Warning, you may seriously injure yourself or others or damage the wheelchair.*

△ WARNING

The wheel stop must embed at least 3/16" into the tire or the chair may roll unexpectedly. Therefore, before adjusting the lock you must inflate the tires to the recommended tire pressure (see sidewall of the tire). If you adjust the locks when the tires are under-inflated, the lock will not operate properly when the tire is fully inflated. *If you ignore this Warning, you may fall, tip over or lose control of the wheelchair and seriously injure yourself or others or damage the wheelchair.*

△ WARNING

After adjusting the wheel locks, engage the wheel locks and push against the tires to verify that the wheel locks prevent the wheels from moving. If not, readjust the wheel locks until the wheel locks securely prevent the chair from rolling. *If you ignore this Warning, you may fall, tip over or lose control of the wheelchair and seriously injure yourself or others or damage the wheelchair.*

Compact Push to Lock

Adjusting

Tools Needed:

- 3/16" Allen Wrench

1. Loosen, but do not remove, the Allen screws in the wheel lock clamp. See Figure 10-1.
2. Adjust the position of the wheel lock clamp on the frame so the wheel stop embeds at least 3/16" into the tire when engaged in the locked position.
3. Securely tighten the two Allen screws that secure the wheel lock clamp to the frame.

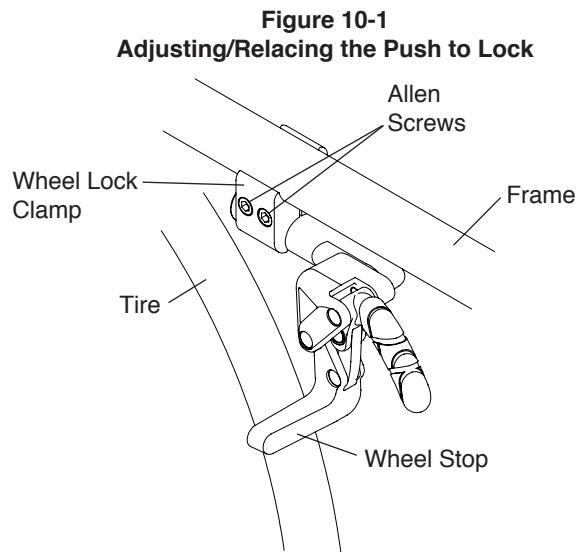

Replacing

Tools Needed:

- 3/16" Allen Wrench

1. Loosen, but do not remove, the two Allen screws that secure the wheel lock clamp to the frame. See Figure 10-1.
2. Slide the wheel lock out of the clamp.
3. Slide the new wheel lock into the wheel lock clamp, but do not tighten the Allen screws.
4. Follow the procedures under "Compact Push to Lock - Adjusting" on page 10-1 to position and secure the new wheel lock.

CHAPTER 10: WHEEL LOCKS

Compact Pull to Lock

Adjusting

Tools Needed:

- 3/16" Allen Wrench

1. Loosen, but do not remove, the Allen screws in the wheel lock clamp. See Figure 10-2.
2. Adjust the position of the wheel lock clamp on the frame so the wheel stop embeds at least 3/16" into the tire when engaged in the locked position.
3. Securely tighten the two Allen screws that secure the wheel lock clamp to the frame.

Figure 10-2
Adjusting/Replacing the Pull to Lock

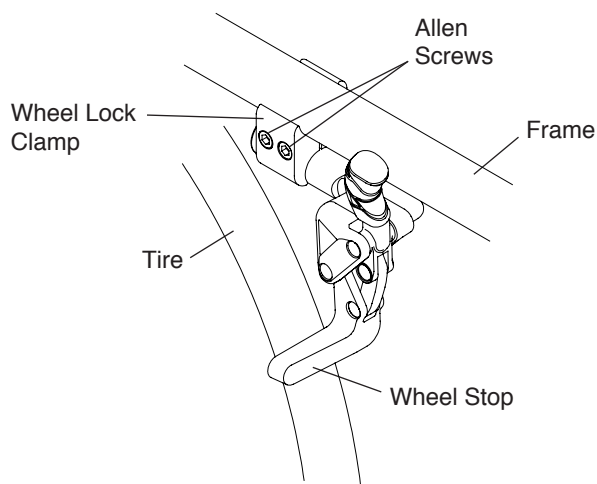

Replacing

Tools Needed:

- 3/16" Allen Wrench

1. Loosen, but do not remove, the two Allen screws that secure the wheel lock clamp to the frame. See Figure 10-2.
2. Slide the wheel lock out of the clamp.
3. Slide the new wheel lock into the wheel lock clamp, but do not tighten the Allen screws.
4. Follow the procedures under "Compact Pull to Lock - Adjusting" on page 10-2 to position and secure the new wheel lock.

Compact Push to Lock and Compact Pull to Lock Wheel Locks with Extension Handles

All of the adjustments set forth under "Compact Push to Lock and Compact Pull to Lock" on pages 10-1 to 10-2 apply to the Compact Push to Lock and Compact Pull to Lock Wheel Locks with Extension Handles.

Compact Scissor Lock

Adjusting

Tools Needed:

- 3/16" Allen Wrench

1. Loosen, but do not remove, the Allen screws in the wheel lock clamp. See Figure 10-3.
2. Adjust the position of the wheel lock clamp on the frame so the wheel stop embeds at least 3/16" into the tire when engaged in the locked position.
3. Securely tighten the two Allen screws that secure the wheel lock clamp to the frame.

Figure 10-3
Adjusting/Replacing the Scissor Lock

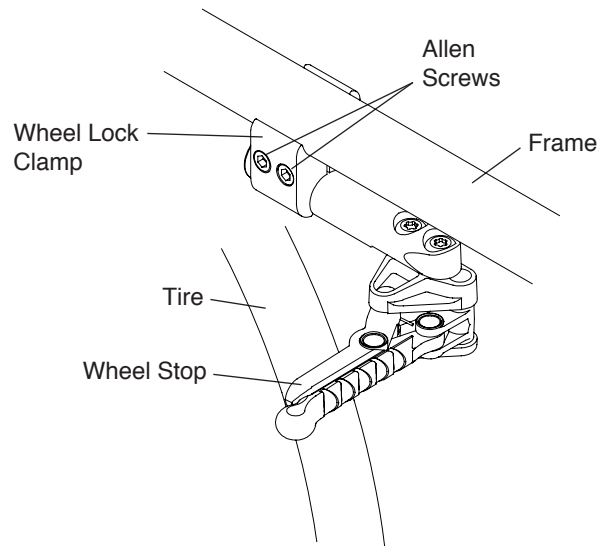

Replacing

Tools Needed:

- 3/16" Allen Wrench

1. Loosen, but do not remove, the two Allen screws that secure the wheel lock clamp to the frame. See Figure 10-3.
2. Slide the wheel lock out of the clamp.
3. Slide the new wheel lock into the wheel lock clamp, but do not tighten the Allen screws.
4. Follow the procedures under "Compact Scissor Lock - Adjusting" on page 10-2 to position and secure the new wheel lock.

Uni-Lock

Adjusting

Tools Needed:

- 3/16" Allen Wrench

1. Loosen, but do not remove, the two Allen screws in the wheel lock clamp. See Figure 10-4.
2. Adjust the position of the wheel lock clamp on the frame so the wheel stop embeds at least 3/16" into the tire when engaged in the locked position.
3. Securely tighten the two Allen screws that secure the wheel lock clamp to the frame.

Figure 10-4
Adjusting/Replacing

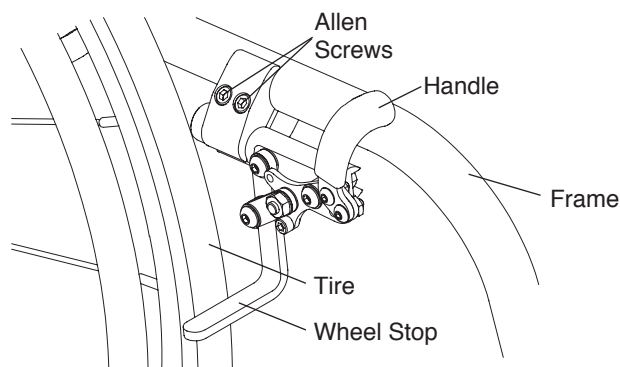

CHAPTER 10: WHEEL LOCKS

Replacing

Tools Needed:

- 3/16" Allen Wrench

1. Loosen, but do not remove, the two Allen screws that secure the wheel lock clamp to the frame. See Figure 10-4.
2. Slide the wheel lock out of the clamp.
3. Slide the new Uni-Lock into the wheel lock clamp, but do not tighten the Allen screws.
4. Follow the procedures under "Uni-Lock - Adjusting" on page 10-3 to position and secure the new wheel lock.

Changing the Uni-Lock from the Push to the Pull Position

Tools Needed:

- 5/32" Allen Wrench

The Uni-Lock wheel lock can be set up so that you either pull the handle to engage the lock or push the handle to engage the lock. To determine which setup you have, locate the small Socket Head Cap screw in the wheel lock handle base. If it is in the upper position (see Figure 10-5), the Uni-Lock is set to the "Pull to Lock" position. If it is in the lower position (see Figure 10-6), the Uni-Lock is set to the "Push to Lock" position.

Figure 10-5
Pull to Lock Position

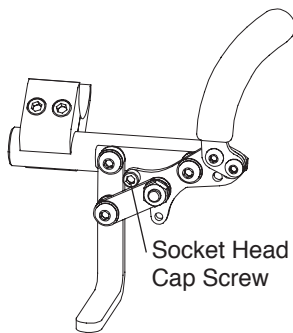
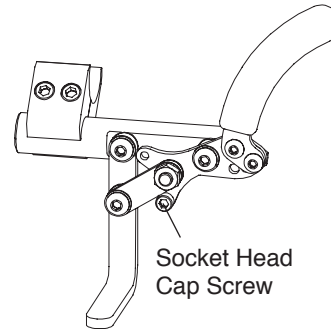

Figure 10-6
Push to Lock Position



You can change the operation from pull to push or vice versa as follows:

1. Make sure the wheel lock has been disengaged from the tire.
2. Remove the Socket Head Cap screw and reposition it to either the "Pull to Lock" or "Push to Lock" position, as desired. See Figure 10-7.
3. Securely tighten the Socket Head Cap screw.

Figure 10-7
Repositioning the Handle

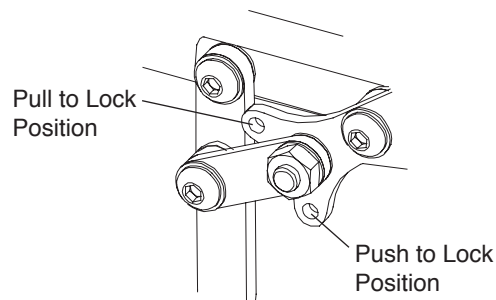

Repositioning the Handle of the Uni-Lock Wheel Lock

Six (6) handle positions are achievable using the Uni-Lock. See Figures 10-8 through 10-11. Each handle position can be used as either a "Pull to Lock" or a "Push to Lock" (see "Changing the Uni-Lock From the Push to the Pull Position" on pages 10-4 through 10-6), resulting in 12 possible Uni-Lock setups.

Figures 10-8 through 10-11 show the handle in both the engaged (locked) and disengaged (unlocked) positions. Study the Figures to determine which handle configuration will work best for you. Follow the directions below to reconfigure your handle to the desired configuration.

Figure 10-8
Standard Handle Positions 1, 2 and 3 (Locked)

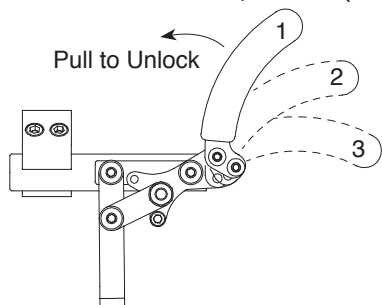

Figure 10-9
Standard Handle Positions 1, 2 and 3 (Unlocked)

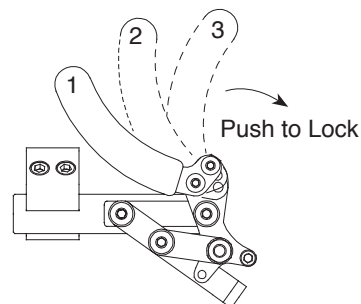

Figure 10-10
Reverse Handle Positions 1, 2 and 3 (Locked)

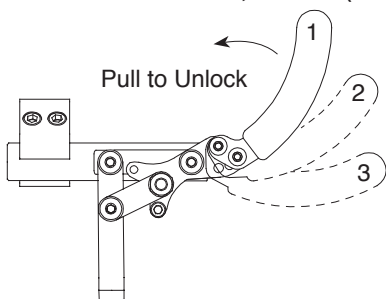
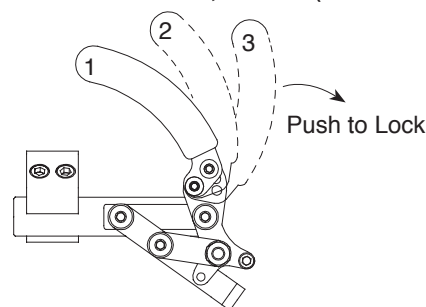

Figure 10-11
Reverse Handle Positions 1, 2 and 3 (Unlocked)



Standard Handle Positions 1, 2, 3

The Uni-Lock ships with the handle in Standard Position 3. If you desire to switch to Standard Positions 1 or 2, follow the procedures below.

Tools Needed:

- 1/8" Allen Wrench
- 3/8" Open End Wrench

1. As shown in Figure 10-12, the wheel lock handle attaches to the wheel lock handle base with two Allen screws. There is only one hole in the wheel lock handle base through which to attach the upper Allen screw. There are three holes in the wheel lock handle base through which to attach the lower Allen screw.
2. Remove the lower Allen screw and locknut that secure the wheel lock handle to the wheel lock handle base.
3. Loosen, but do not remove, the upper Allen screw that secures the wheel lock handle to the wheel lock handle base.
4. Reposition the wheel lock handle to the desired Standard Handle Position 1, 2 or 3 (see Figures 10-8 and 10-9) and replace the Allen screw and locknut.
5. Securely tighten both Allen screws and locknuts.

Figure 10-12
Removing the Wheel Lock Handle

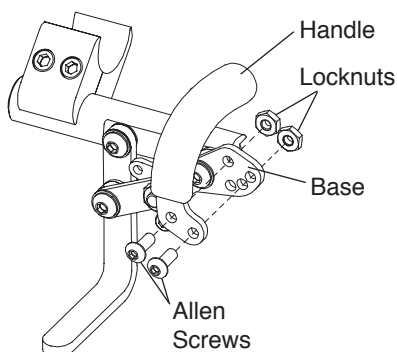

CHAPTER 10: WHEEL LOCKS

Reversed Handle Positions 1, 2, 3

You can achieve three additional wheel lock handle positions for your Uni-Lock by reversing the wheel lock handles from the right and left Uni-Locks. To do this, follow the procedures below.

Tools Needed:

- 1/8" Allen Wrench
- 3/8" Open End Wrench

1. Remove the two Allen screws and locknuts that secure the wheel lock handle to the wheel lock handle base on both the right and left Uni-locks. See Figure 10-12.
2. Install the wheel lock handle from the left Uni-Lock on the right Uni-Lock in the desired position (see Figures 10-10 and 10-11).
3. Install the wheel lock handle from the right Uni-Lock on the left Uni-Lock.
4. Securely tighten all screws and locknuts.

Uni-Lock with Extension Handles

All of the adjustments set forth under "Uni-Lock" on pages 10-3 to 10-6 apply to the Uni-Lock with Extension Handles.

Aluminum Scissor Lock

Adjusting

Tools Needed:

- 3/16" Allen Wrench

1. Loosen, but do not remove, the two Allen screws in the wheel lock clamp. See Figure 10-13.
2. Adjust the position of the wheel lock clamp on the frame so the wheel stop embeds at least 3/16" into the tire when engaged in the locked position.
3. Securely tighten the two Allen screws that secure the wheel lock clamp to the frame.

Figure 10-13
Adjusting/Replacing the Aluminum Wheel Lock

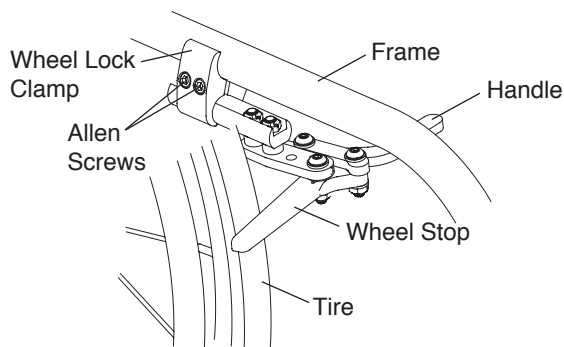

Replacing

Tools Needed:

- 3/16" Allen Wrench

1. Loosen, but do not remove, the two Allen screws that secure the wheel lock clamp to the frame. See Figure 10-13.
2. Slide the wheel lock out of the clamp.
3. Slide the new Aluminum Scissor Lock into the wheel lock clamp, but do not tighten the two Allen screws.
4. Follow the procedure under "Aluminum Scissor Lock - Adjusting" on page 10-6 to position and secure the new Aluminum Scissor Lock.

CHAPTER 11: CASTERS, FORKS AND CASTER PIN LOCKS

Casters and Forks

⚠ WARNING

Always mount identical size casters and forks on both sides of your chair. *If you ignore this Warning, you may fall, tip over or lose control of the wheelchair and seriously injure yourself or others or damage the wheelchair.*

Replacing Casters

Tools Needed:

- Two #2 Phillips Head Screw Drivers

1. Remove the two Phillips Head screws, C Spring washers and axle that secure the caster to the fork. Use one screw driver to hold one screw in place and a second screw driver to loosen the other screw. See Figures 11-1 and 11-2.
2. Remove the caster and spacers from the fork.
3. Install the new caster, spacers and C Spring washers onto the fork and securely tighten the two screws so there is no space between the caster, the spacers and the fork sides. Use one screw driver to hold one screw in place and securely tighten the other screw with the second screw driver.

Note: If your chair has 4" or 5" TiLite Performance casters, make sure that Spacer 2 (which is wider than Spacer 1) is positioned on the recessed side of the caster, which should be oriented outwards when the casters are in the trailing position.

Figure 11-1
TR/YR Series 2 Bearing Fork

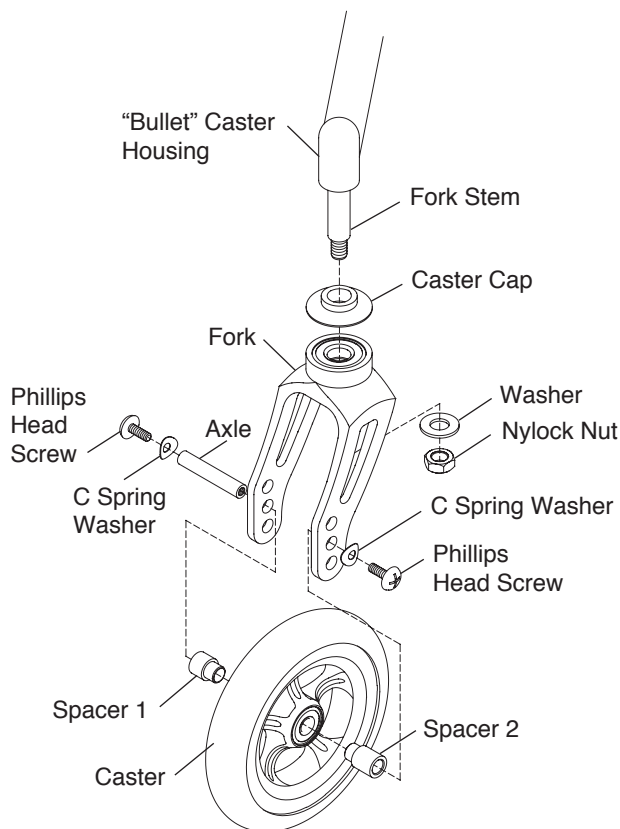
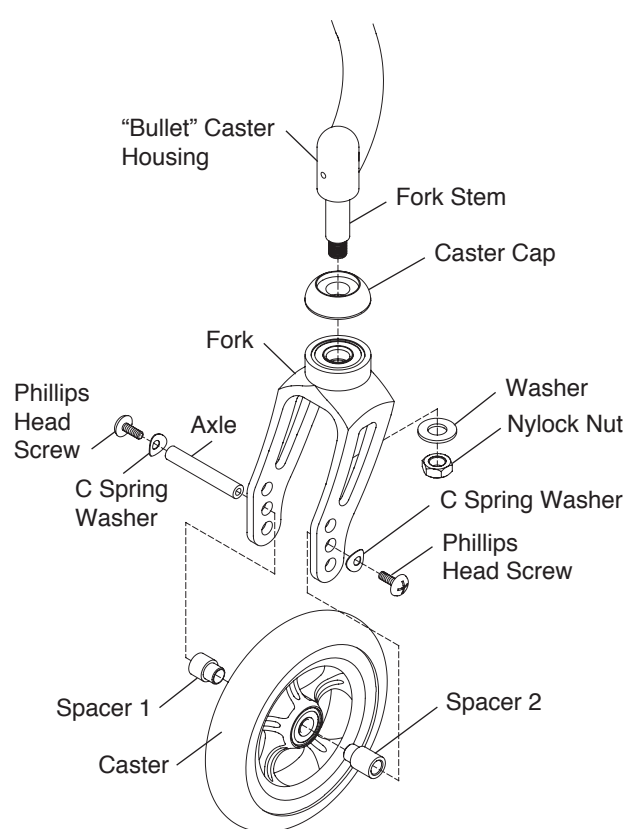

Figure 11-2
TR Series 3 Bearing Fork



⚠ WARNING

The threads on the screws that secure the casters to the fork are treated with Vibra-TITE® VC-3, a locking and sealing coating, to reduce the possibility they will become loose. You should be able to remove and reinstall these screws approximately four times without reapplying the coating. If you repeatedly remove and reinstall these screws, TiLite requires that you reapply Vibra-TITE® VC-3 after every fourth adjustment. *If you ignore this Warning, you may fall, tip over or lose control of the wheelchair and seriously injure yourself or others or damage the wheelchair.*

CHAPTER 11: CASTERS, FORKS AND CASTER PIN LOCKS

Replacing Forks

Tools Needed:

- 9/16" Socket Wrench

⚠ WARNING

The fork stem is permanently installed in the "Bullet" Caster Housing. Do not attempt to unscrew the fork stem or the set screw. If it should become necessary to replace the fork stem on these chairs, this repair can only be performed by TiLite at our factory. *If you ignore this Warning, you may fall, tip over or lose control of the wheelchair and seriously injure yourself or others or damage the wheelchair.*

1. Remove the casters. See "Replacing Casters" on page 11-1.
2. Loosen and remove the nylock nut and washer that secure the fork to the fork stem. See Figures 11-1 and 11-2.
3. Remove the old fork and caster cap and install the replacement fork and old caster cap on the fork stem.
4. Replace the nylock nut and washer and securely tighten.
5. Reinstall the casters. See "Replacing Casters" on page 11-1.

CASTERS with MONO FORKS

(TR Series 3)

Replacing Casters

Tools Needed:

- 1/8" Allen Wrench

1. Remove the Allen screw and caster cap from the caster. See Figure 11-3.
2. Remove the caster from the Mono Fork.
3. Install the new caster onto the Mono Fork, replace the single sided caster cap and securely tighten the screw so there is no space between the caster and the Mono Fork side.

⚠ WARNING

The threads on the screws that secure the casters to the fork are treated with Vibra-TITE® VC-3, a locking and sealing coating, to reduce the possibility they will become loose. You should be able to remove and reinstall these screws approximately four times without reapplying the coating. If you repeatedly remove and reinstall these screws, TiLite requires that you reapply Vibra-TITE® VC-3 after every fourth adjustment. *If you ignore this Warning, you may fall, tip over or lose control of the wheelchair and seriously injure yourself or others or damage the wheelchair.*

Replacing Forks

Tools Needed:

- 9/16" Wrench
- 1/8" Allen Wrench

1. Remove the casters. See "Replacing Casters" on page 11-2.
2. Remove the nylock nut and washer that secure the fork to the fork stem. See Figure 11-3.
3. Remove the old fork and install the replacement fork on the fork stem.
4. Replace the nylock nut and washer and securely tighten.
5. Reinstall the casters. See "Replacing Casters" on page 11-2.

Figure 11-3
TR Series 3 Mono Fork

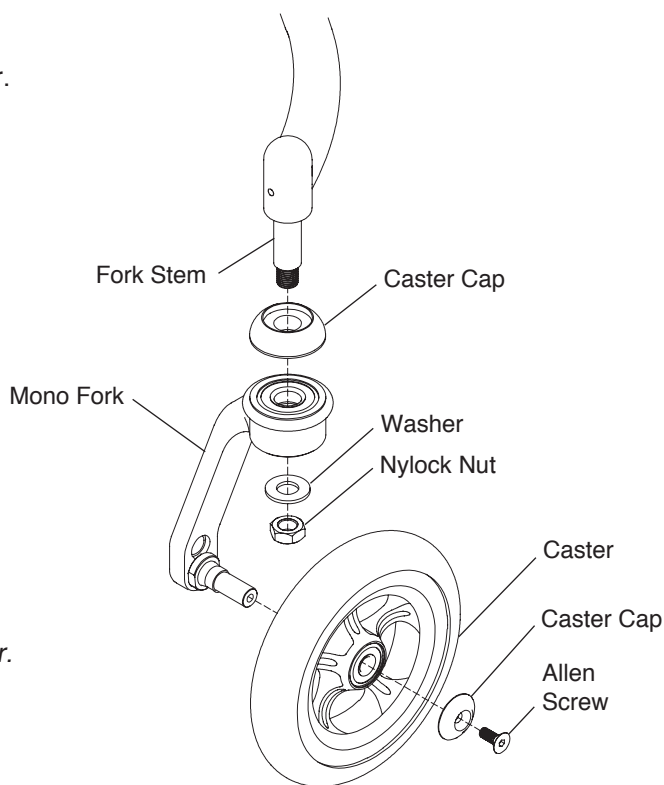

CHAPTER 11: CASTERS, FORKS AND CASTER PIN LOCKS

⚠ WARNING

On the TR Series 3, the fork stem is permanently installed in the “Bullet” Caster Housing. Do not attempt to unscrew the fork stem or the set screw. If it should become necessary to replace the fork stem on these chairs, this repair can only be performed by TiLite at our factory. *If you ignore this Warning, you may fall, tip over or lose control of the wheelchair and seriously injure yourself or others or damage the wheelchair.*

Caster Pin Locks

(TR and YR Series 2)

⚠ WARNING

ALWAYS be sure to disengage both Caster Pin Locks before attempting to propel your chair. *If you ignore this Warning, you may fall, tip over or lose control of the wheelchair and seriously injure yourself or others or damage the wheelchair.*

To engage the Caster Pin Locks:

1. Rotate the caster until either notch on the lock ring is directly beneath the T-Handle. See Figure 11-4.
2. Lift, rotate and lower the T-handle down into the lower notch on the Caster Pin Lock. See Figure 11-5.
3. Make sure the pin lock is fully engaged in one of the notches in the lock ring.

To disengage the Caster Pin Lock, lift, rotate and lower the T-Handle down into the upper notch on the Caster Pin Lock. See Figure 11-4

Figure 11-4
Caster Pin Lock in Unlocked Position

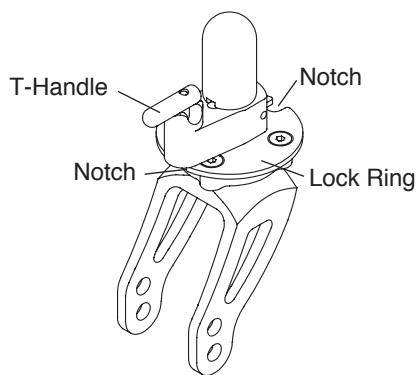
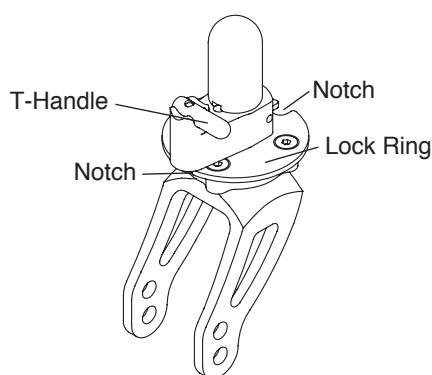

Figure 11-5
Caster Pin Lock in Locked Position



Floating Casters

Tools needed:

- 3/16" Allen Wrench
- 1/8" Allen Wrench
- Wood Block (1" Minimum)
- Drafting Triangle
- Ruler

Note: TiLite designs its rigid wheelchairs to be flexible for improved maneuverability and increased ride comfort. However, this flexibility requires that your chair be set up properly. The following procedure will enable you to set up your TiLite rigid wheelchair so it will perform to its potential.

1. Place the wheelchair on a smooth, level surface.
2. Make sure that all tires are properly inflated, that the camber tube is properly centered on the frame side to side, that the camber tube is straight relative to the rear of the frame, that the toe-in/toe-out is correctly set up, and the angle adjustable casters are square to level surface.
3. Loosen, but do not remove, the Allen screws in the camber tube clamps as shown in Figure 11-6.

Note: Figure 11-6 depicts the camber tube clamps on the TR and YR Series 2. If you have a TR Series 3, locate the corresponding Allen screws that secure the camber tube clamp to the frame and the camber tube to the camber tube clamp.

CHAPTER 11: CASTERS, FORKS AND CASTER PIN LOCKS

- Loosen, but do not remove, the Allen screws in the footrest clamps as shown in Figure 11-7.

Note: Figure 11-7 depicts the footrest clamps on the TR and YR Series 2. If you have the TR Series 3, locate the corresponding screw that secures the footrest assembly to the frame.

- Make sure your footrest is set to your desired seat-to-footrest measurement, and, using a ruler, make sure the left and right sides of the footrest are the same distance to the level surface.
- If the above adjustments correct the floater, securely tighten all Allen screws loosened in Steps 3 and 4. If not, proceed to Steps 7 through 9.
- While applying gentle downward pressure on the top of the floating caster housing, securely tighten the Allen screw in the footrest clamp on that side of the chair.
- Securely tighten all Allen screws on the camber tube clamps, starting with the screws that secure the camber tube to the camber tube clamp (do not start with the screws that secure the clamp to the frame).
- Check to make sure all of the wheels are flat on your level surface and that neither caster is “floating.” If all wheels are flat and you have no floaters, securely tighten the remaining screws. If you still have a floating caster, proceed to Steps 10 through 13.
- Loosen, but do not remove, the Allen screw on the footrest clamp only on the side of the chair with the floating caster.
- Place a wood block under the other caster wheel (which is not floating) as shown in Figure 11-8.
- Apply gentle downward pressure on the caster wheel that is floating. It is advisable that you have an assistant to place downward pressure on the opposite side of the chair at the backrest when making this adjustment.
- Remove the wood block and check to see if the caster still floats. If the caster no longer floats, securely tighten the Allen screw on the footrest clamp. If the caster still floats, or if the other caster starts to float, repeat Steps 10 through 13 until the caster no longer floats.

Figure 11-6
Allen Screws on Camber Clamp

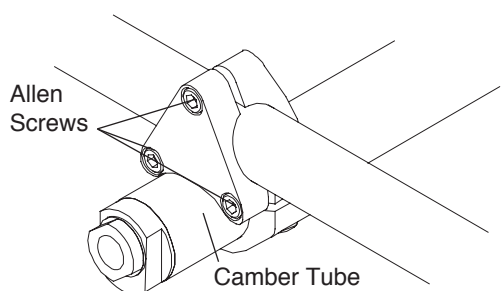

Figure 11-7
Allen Screws on Footrest Clamp

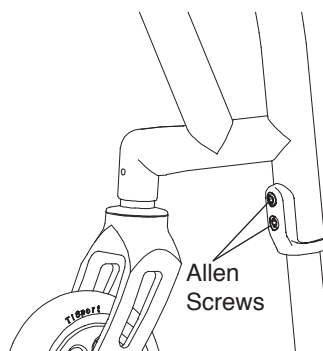
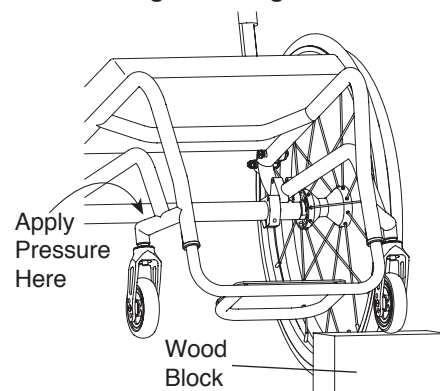

Figure 11-8
Fixing a Floating Caster



Frog Legs®

⚠ WARNING

Always mount identical size casters and forks on both sides of your chair. *If you ignore this Warning, you may fall, tip over or lose control of the wheelchair and seriously injure yourself or others or damage the wheelchair.*

Replacing Casters

Tools Needed:

- Two #2 Phillips Head Screw Drivers

- Remove the Allen screw, washer, C spring washer, and axle that secure the caster to the fork. Use one screw driver to hold the axle in place and a second screw driver to loosen the other screw. See Figure 11-10.
- Remove the caster and spacers from the fork.
- Install the new caster, spacers, washer and C spring washer onto the fork and securely tighten the two screws so there is no space between the caster, the spacers and the fork sides. Use one screw driver to hold the axle in place and securely tighten the other screw with the second screw driver.

Note: If your chair has 4" or 5" TiLite performance casters, make sure that Spacer 2 (which is wider than Spacer 1) is positioned on the recessed side of the caster, which should be oriented outwards when the casters are in the trailing position.

CHAPTER 11: CASTERS, FORKS AND CASTER PIN LOCKS

Replacing the Elastomer Shock

Tools Needed:

- Two 5/32" Allen Wrench

1. Remove Allen screws from the hinge and push out the threaded spacer. See Figure 11-9.
2. Separate the two halves of the Frog Legs® to release the elastomer shock.

Note: The metal disc is glued to the top of the elastomer shock.

3. Install the new elastomer shock (making sure the metal disc is facing upward).
4. Push firmly on the two halves of the Frog Legs® to facilitate reinstalling the Allen screws and threaded spacer.

Figure 11-9
Replacing the Elastomer Shock on Frog Legs®

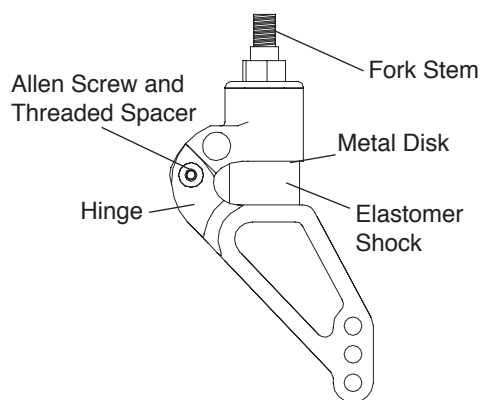

⚠ WARNING

The threads on the Allen screw that connects the two halves of the Frog Leg® are treated with Loctite® 242®, a medium strength thread lock. If you loosen this Allen screw, you **MUST** remove and reapply Loctite® 242® or an equivalent medium strength thread lock. *If you ignore this Warning, your rear wheel could become loose or fall off and you could fall, tip over or lose control of the wheelchair and seriously injure yourself or others or damage the wheelchair.*

Replacing Frog Legs®

Tools Needed:

- 5/8" Open End Wrench
- Torque Screw Driver with a 5/64" hex tip

⚠ WARNING

The threads on the screws that secure the stem bolt to the "Bullet" Caster Housing and the set screw are treated with Vibra-TITE® VC-3, a locking and sealing coating, to reduce the possibility they will become loose. You should be able to remove and reinstall these screws and bolts approximately four times without reapplying the coating. If you repeatedly remove and reinstall these screws and stem bolts, TiLite requires that you reapply Vibra-TITE® VC-3 after every fourth adjustment. *If you ignore this Warning, you may fall, tip over or lose control of the wheelchair and seriously injure yourself or others or damage the wheelchair.*

⚠ WARNING

The threads on the screws that secure the casters to the fork and the axles are treated with Vibra-TITE® VC-3, a locking and sealing coating, to reduce the possibility they will become loose. You should be able to remove and reinstall these screws and axles approximately four times without reapplying the coating. If you repeatedly remove and reinstall these screws or axles, TiLite requires that you reapply Vibra-TITE® VC-3 after every fourth adjustment. *If you ignore this Warning, you may fall, tip over or lose control of the wheelchair and seriously injure yourself or others or damage the wheelchair.*

CHAPTER 11: CASTERS, FORKS AND CASTER PIN LOCKS

⚠ WARNING

The fork stems on Frog Legs® made for the TiLite TR and YR are a custom size. Therefore, if you need to replace your Frog Leg® forks or stems, you must order replacements from TiLite. *If you ignore this Warning, the new Frog Legs® that you purchase will not fit into the “Bullet” Caster Housing on your TiLite TR or YR.*

1. Remove the casters. See “Replacing Casters” on page 11-4.
2. Remove the set screw that secures the stem bolt inside the “Bullet” Caster Housing.
3. Loosen and remove the stem bolt using the Open End wrench on the flats indicated in Figure 11-10.
4. After properly treating the new Frog Legs® fork stem with Vibra-TITE® VC-3, install the new stem bolt into the “Bullet” Caster Housing and securely tighten.
5. After properly treating the set screw with Vibra-TITE® VC-3, install the set screw fully into the “Bullet” Caster Housing and tighten to 32 inch-lbs.
6. Reinstall the casters. See “Replacing Casters” on page 11-4.

Figure 11-10
Replacing Frog Legs®

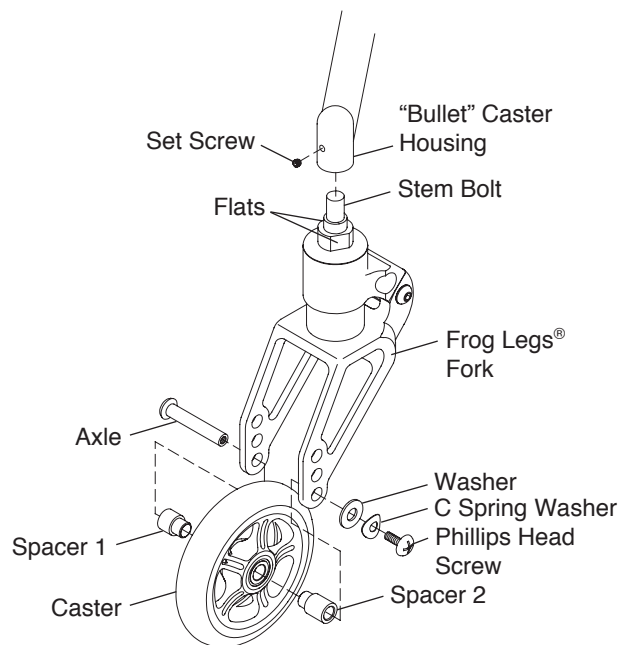

⚠ WARNING

DO NOT attempt any of the procedures in this Chapter if the chair is occupied. *If you ignore this Warning, serious injury to the occupant will occur.*

Quick-Release Axle

Removing

1. Hold wheel securely at the hub. See Figure 12-1.
2. Depress the release button on the Quick-Release Axle and slide the wheel and axle out of the axle sleeve.
3. Release the release button.

Replacing

⚠ WARNING

Make sure the locking balls fully secure the Quick-Release Axle inside the axle sleeve before operating the chair. *If you ignore this Warning, you may fall, tip over or lose control of the wheelchair and seriously injure yourself or others or damage the wheelchair.*

1. Hold the wheel securely at the hub. See Figure 12-1.
2. Depress the release button on the Quick-Release Axle, making sure the locking balls recess into the axle.
3. Insert the axle all the way into the axle sleeve.
4. Release the release button.
5. Pull firmly on the wheel (without depressing the release button) to make sure the wheel is locked securely in place.

Figure 12-1
Removing and Replacing the Rear Wheel with the Quick-Release Axle

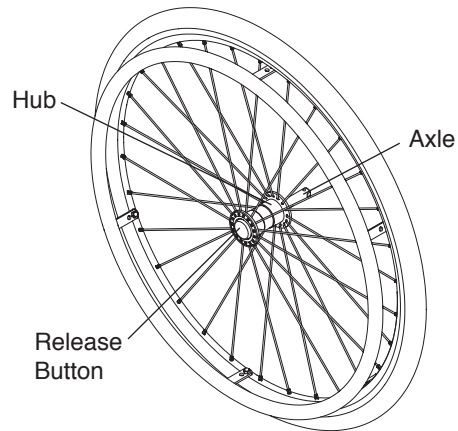

Quad Quick-Release Axle

Removing

1. Unlock the lever on the Quad Quick-Release Axle. See Figure 12-2.
2. Slide wheel and axle out of the axle sleeve.

Replacing

⚠ WARNING

Make sure the locking balls fully secure the Quad Quick-Release Axle inside the axle sleeve before operating the chair. *If you ignore this Warning, you may fall, tip over or lose control of the wheelchair and seriously injure yourself or others or damage the wheelchair.*

1. Hold the wheel securely at the hub. See Figure 12-2.
2. Unlock lever on the Quad Quick-Release Axle, making sure the locking balls recess into the axle.
3. Insert the axle all the way into axle sleeve.
4. Lock the lever on the Quad Quick-Release Axle.
5. Pull firmly on the wheel (without unlocking the lever) to make sure the wheel is locked securely in place.

Figure 12-2
Removing and Replacing the Rear Wheel with the Quad Quick-Release Axle

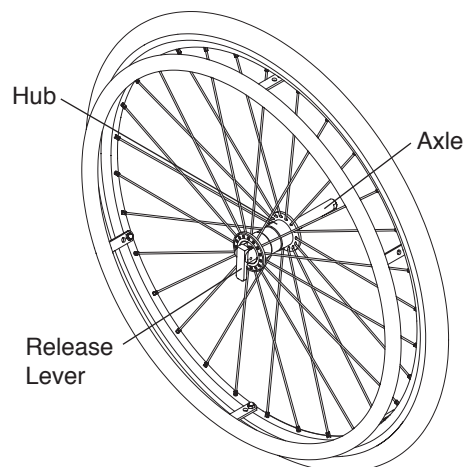

CHAPTER 12: REAR WHEELS

Handrims

⚠ WARNING

You must have your handrims replaced by an authorized TiLite dealer or qualified technician. *If you ignore this Warning, you may seriously injure yourself or others or damage the wheelchair.*

Pneumatic Tires and Tubes

⚠ WARNING

Fully deflate the tire before performing any disassembly procedures. Do not re-inflate the tire until all re-assembly is completed. *If you ignore this Warning, you may seriously injure yourself or others or damage the wheelchair.*

Tools needed:

- #2 Phillips Screw Driver
- 3/8" Open End Wrench or 5/16" Open End Wrench

1. Remove the rear wheel from the chair.
2. Remove all air from the inner tube. If you have a Schrader valve (see Figure 12-3), remove valve stem cap and release all of the air from the tube, by pressing down on the pin in the center of the valve stem. If you have a Presta valve (see Figure 12-4), remove the valve stem cap, unscrew, counter clockwise, the knurled nut on the valve stem and release all of the air from the tube by pressing down on the pin in the center of the valve stem.
3. Remove the tire and inner tube.
4. Make sure the rim strip is properly in place.
5. Install the new inner tube and wheel tire onto the wheel.
6. Make sure the tire is properly seated in the wheel rim and free of protrusions. Inflate the tire to the correct PSI rating on the sidewall of the tire.
7. Reinstall the rear wheel on the chair.

Figure 12-3
Schrader Valve

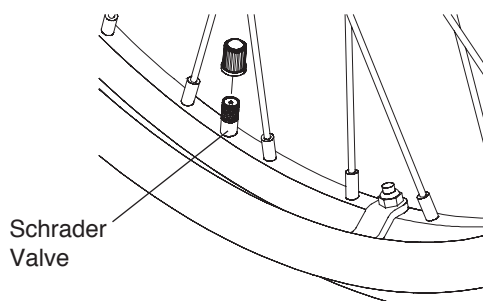
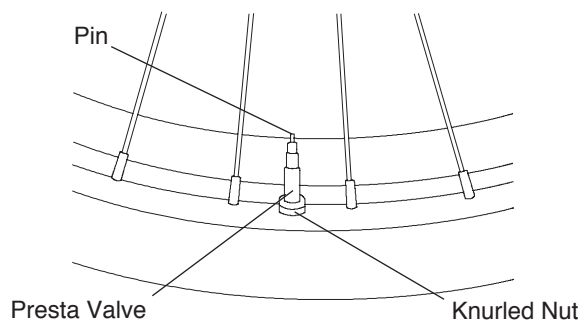

Figure 12-4
Schrader Valve



Solid Tires

⚠ WARNING

Replacement of solid tires requires specialized equipment. Therefore, if your solid tires need replacement, you must have this done by an authorized TiLite dealer or qualified technician. *If you ignore this Warning, you may seriously injure yourself or others or damage the wheelchair.*

Rear Wheel Spacers

⚠ WARNING

Never use rear wheel spacers with the Adjustable Camber System. *If you ignore this Warning, you may fall, tip over or lose control of the wheelchair and seriously injure yourself or others or damage the wheelchair.*

Adjusting Rear Wheel Spacing

⚠ WARNING

Make sure you use the same spacers on both sides of the chair. Do not use spacers exceeding a total of 3/4". If more than 3/4" of the axle sleeve is outside of the camber plug, the axle sleeve could disengage from the camber plug while you are using the chair. *If you ignore this Warning, you may fall, tip over or lose control of the wheelchair and seriously injure yourself or others or damage the wheelchair.*

Tools needed:

- 7/8" Open End Wrench
- 3/4" Open End Torque Wrench

1. Place the 7/8" Open End wrench onto the camber plug and use the 3/4" Open End Torque wrench to remove the axle sleeve. See Figure 12-5.
2. Add or delete the spacers you need to increase/ decrease your rear wheel spacing, keeping the two washers against the head of the axle sleeve.
3. After you have adjusted your rear wheel spacing, reinstall the axle sleeve in the camber plug and hand-tighten.
4. Using a torque wrench, tighten the axle sleeve to 230 inch-pounds.

Figure 12-5
Rear Wheel Spacing

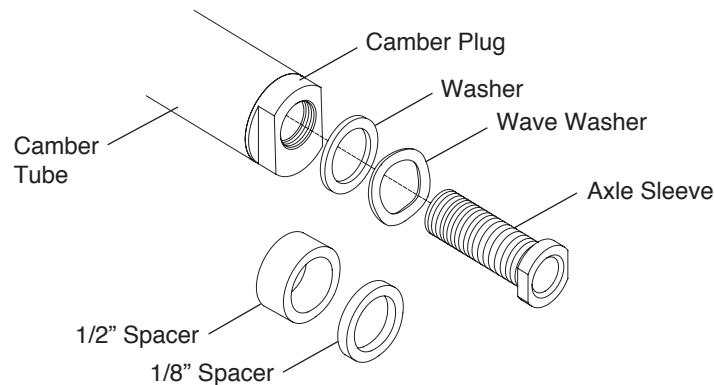

Rear Anti-Tips

Adjusting

1. The bottom of the anti-tip wheels should be between 1-1/2" and 2" above the floor to ensure proper functionality. To adjust the height, press the two release buttons on the telescoping lower tube, then adjust the height of the lower tube. See Figures 13-1 and 13-2.
2. To rotate the anti-tips upward, press the release button at the top of the extension tube to release the extension tube and rotate upward until the release button locks in place on the opposite side of the anti-tip receiver.
3. To remove the anti-tip, press the release button at the top of the extension tube and pull the extension tube out of the anti-tip receiver.

Figure 13-1
TR/YR Series 2 Adjusting

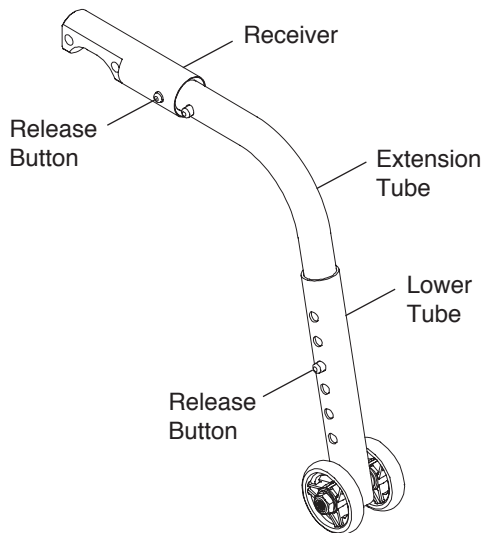
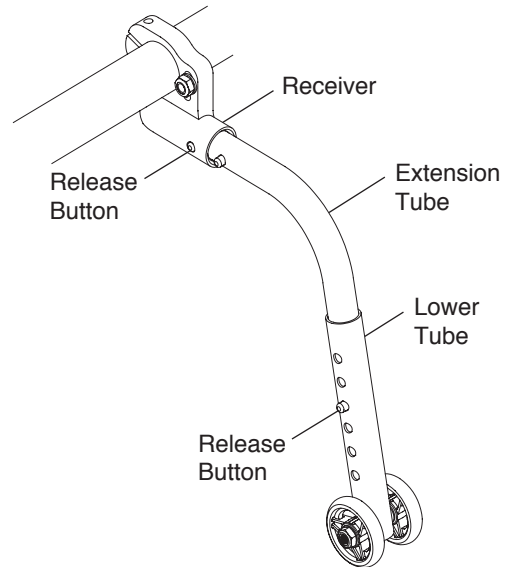

Figure 13-2
TR Series 3 Adjusting



Mounting

(TR and YR Series 2)

⚠ WARNING

Only an authorized TiLite dealer or qualified technician should install the rear anti-tip receiver. *If you ignore this Warning, you may fall, tip over or lose control of the wheelchair and seriously injure yourself or others or damage the wheelchair.*

Note: Unless you ordered anti-tips when you originally ordered your TiLite wheelchair, you will need to order replacement Allen screws when ordering anti-tips. You will also need to order new camber mounts and a camber tube clamp. See Figure 13-3.

Tools Needed:

- 3/16" Allen Wrench

1. Remove the rear wheels and place the frame on a level surface.
2. Remove the Allen screws that secure the camber mounts to the frame. See Figure 8-1. Remove the Allen screws that secure the camber tubes to the camber mounts. See Figure 8-3.
3. Using the new components referenced in the note above, align the two holes in the anti-tip receiver with the two holes in the camber tube clamp and with the anti-tip receiver positioned over the camber tube and facing rearward. See Figure 13-3.
4. Insert the replacement Allen screws through the anti-tip receiver, the camber tube clamp, the non-threaded camber mount and into the threaded camber mount.
5. Securely tighten.
6. Reinstall the rear wheels.

CHAPTER 13: ANTI-TIPS

Figure 13-3
Mounting

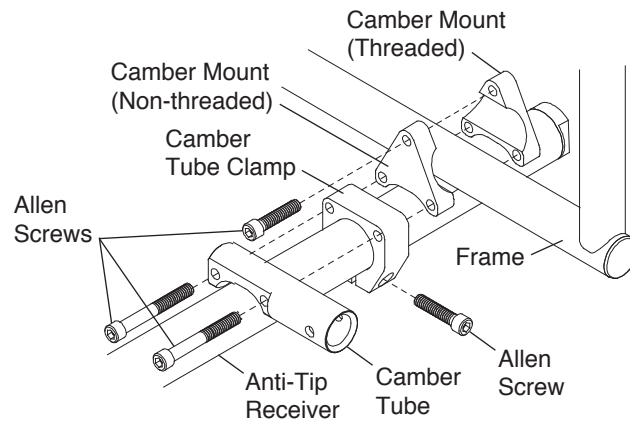

Mounting (TR Series 3)

⚠ WARNING

Only an authorized TiLite dealer or qualified technician should install the rear anti-tip receiver. *If you ignore this Warning, you may fall, tip over or lose control of the wheelchair and seriously injure yourself or others or damage the wheelchair.*

Tools Needed:

- 5/32" Allen Wrench
- 3/16" Allen Wrench
- 7/16" Open End Wrench
- 5/64" Allen Wrench

1. Remove the rear wheels and place the frame on a level surface.
2. Using the 5/64" Allen wrench, remove the camber mount bumper assembly.
3. Remove the camber tube. See "Replacing the Camber Tube (TR Series 3)" on pages 8-3 and 8-4.
4. Thread the Allen screw through the right side camber mount, right side anti-tip receiver and washer and secure the nylock nut. See Figure 13-4.

Note: Make sure that the anti-tip receiver is oriented to be parallel to the floor.

5. Repeat Step 3 on the left side camber mount and the left side anti-tip receiver.
6. Reinstall the camber tube. See "Replacing the Camber Tube (TR Series 3)" on pages 8-3 and 8-4.
7. Tighten the Allen screw in each anti-tip receiver so that it securely clamps into the camber tube.
8. Reinstall the rear wheels.

Figure 13-4
Mounting

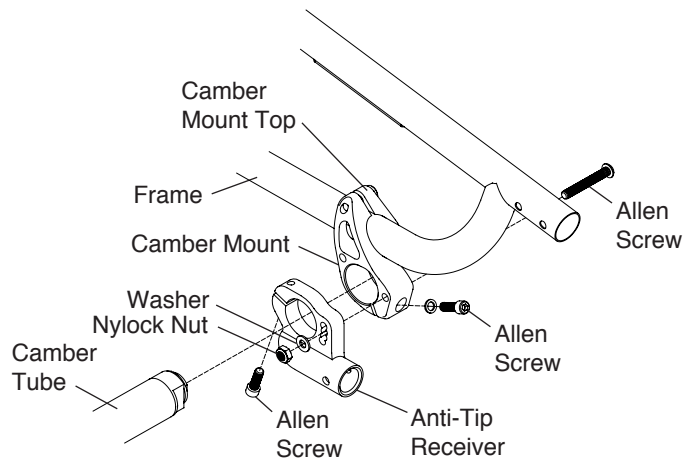

Note: If your TR Series 2 or 3 or YR has Frog Legs® rear suspension and you are installing anti-tips, you must follow the procedure below:

Tools Needed:

- 5/32" Allen Wrench

1. Remove the rear wheels and place the frame on a level surface.
2. Install the anti-tip receiver and spacer using the two Allen screws. See Figure 13-5.
3. Securely tighten.
4. Repeat Steps 2 and 3 on the other side of the chair.

⚠ WARNING

The threads on the Allen screws that connect the anti-tip receiver to the Frog Leg Suspension are treated with Loctite® 242®, a medium strength thread lock. If you loosen either Allen screw, you **MUST** remove and reapply Loctite® 242® or an equivalent medium strength thread lock. *If you ignore this Warning, your anti-tips may not operate properly or fall off and you could fall, tip over or lose control of the wheelchair and seriously injure yourself or others or damage the wheelchair.*

Figure 13-5
Mounting the Anti-Tip Receiver with Frog Legs®

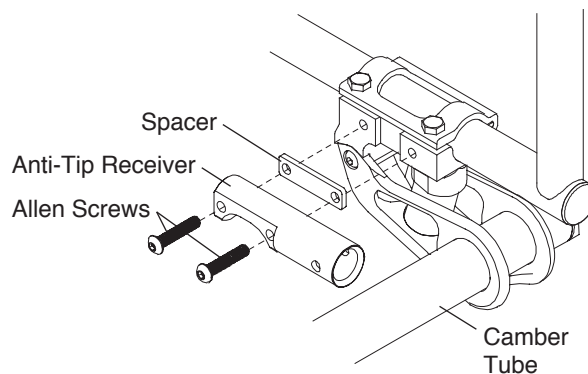

CHAPTER 13: ANTI-TIPS

User-Friendly Rear Flip-Up Anti-Tips

(TR and YR Series 2)

Figure 13-6 shows the configuration of the User-Friendly Rear Flip-Up Anti-Tip.

Figure 13-6
User-Friendly Anti-Tip Configuration

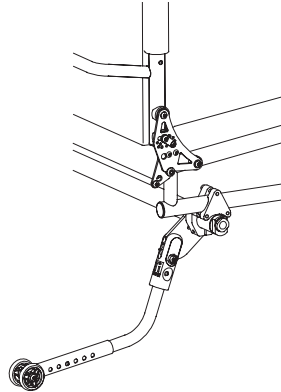

Engaging

To engage the User-Friendly Rear Flip-Up Anti-Tip, grip the anti-tip receiver firmly and pull it rearward, away from the anti-tip mounting plate, and lower it until it re-engages in the mounting plate in the position shown in Figure 13-7.

Figure 13-7
Engaging

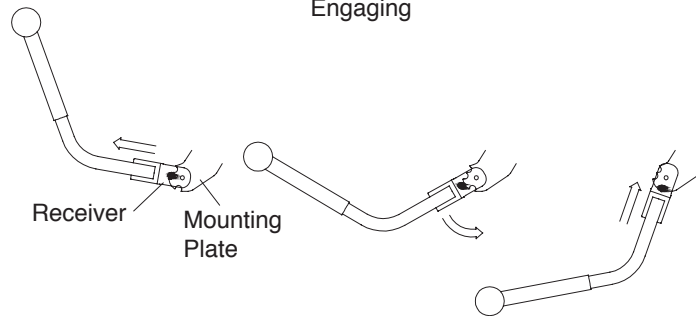

Disengaging

To disengage the User-Friendly Rear Flip-Up Anti-Tip, grip the anti-tip receiver firmly and pull it downward, away from the anti-tip mounting plate, and raise it until it re-engages in the mounting plate in the position shown in Figures 13-8.

Figure 13-8
Disengaging

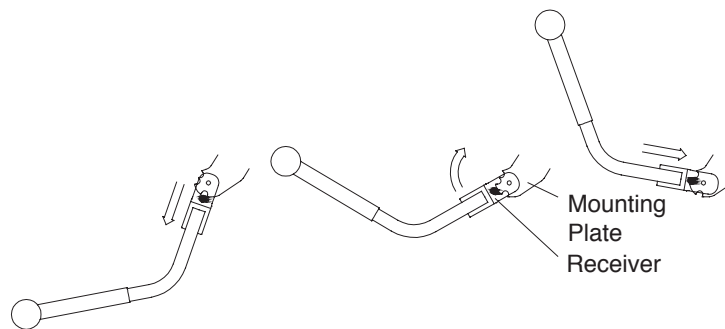

Adjusting

To adjust the height of the User-Friendly Rear Flip-Up Anti-Tip, press the two release buttons on the telescoping lower tube and adjust the height of the lower tube so that the wheel is within 1-1/2" to 2" off the ground. See Figure 13-9.

Figure 13-9
Adjusting

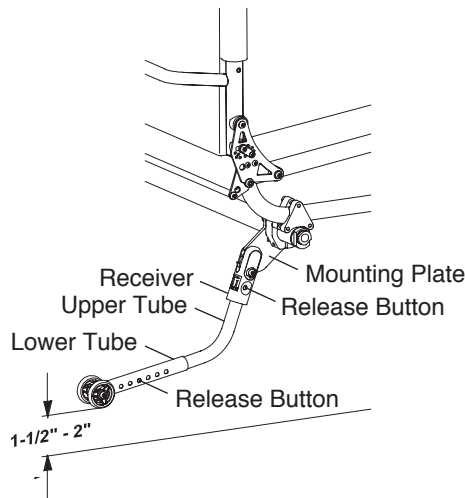

Removing

To remove the User-Friendly Rear Flip-Up Anti-Tip extension tube, press the release buttons on the anti-tip receiver and pull the upper extension tube out of the anti-tip receiver. See Figure 13-9.

Mounting

⚠ WARNING

Only an authorized TiLite dealer or qualified technician should install the rear anti-tip receiver. *If you ignore this Warning, you may fall, tip over or lose control of the wheelchair and seriously injure yourself or others or damage the wheelchair.*

⚠ WARNING

Do not disassemble the anti-tip mounting assembly. See Figure 13-10. *If you ignore this Warning, you may fall, tip over or lose control of the wheelchair and seriously injure yourself or others or damage the wheelchair.*

Note: Unless you ordered the User-Friendly Rear Flip-Up Anti-Tips when you originally ordered your TR or YR Series 2, you will need to order replacement Allen screws, camber mounts and camber clamps when ordering User-Friendly Rear Flip-Up Anti-Tips.

Tools Needed:

- 3/16" Allen Wrench

1. Remove the rear wheels and place the frame on a level surface.
2. Remove the camber tube. See "Replacing the Camber Tube (TR and YR Series 2)" on page 8-2.
3. Note the location of the right camber mounts on the right frame tube and then remove the right camber mounts. See "Adjusting the Center of Gravity (TR and YR Series 2)" on page 8-1.
4. Align the new camber mounts, the new camber clamp and the new mounting plate (discussed in the Note above) as shown in Figure 13-10 on the right side of the chair. Secure using the three new Allen screws. Do not disassemble the anti-tip mounting plate from the anti-tip receiver.
5. Repeat Steps 2 through 4 on the left side of the chair.
6. Reinstall the camber tube. See "Replacing the Camber Tube (TR and YR Series 2)" on page 8-2.

⚠ WARNING

Make sure that the TiLite logo is visible on the rearward side of the User-Friendly Rear Flip-Up Anti-Tip receivers as shown in Figure 13-10 and that the white arrows are all aligned on the opposite (forward) side of the anti-tip components as shown in Figure 13-10. *If you ignore this Warning the anti-tips will not function correctly, and you may fall, tip over or lose control of the wheelchair and seriously injure yourself or others or damage the wheelchair.*

CHAPTER 13: ANTI-TIPS

7. Securely tighten all Allen screws.
8. Reinstall the rear wheels.
9. With the wheelchair standing upright on a level surface, engage the anti-tip as described under “User-Friendly Rear Flip-Up Anti-Tips - Engaging” on page 13-4.
10. Adjust the height of the anti-tip as described under “User-Friendly Rear Flip-Up Anti-Tips - Adjusting” on page 13-5.
11. Check the toe-in/toe-out and adjust as needed.

⚠ WARNING

Before sitting in the chair, make sure that the anti-tips are operating properly. To do this, place the unoccupied chair on a level surface, engage the anti-tips, and tip the chair backward until the anti-tips are supporting the weight of the chair. Apply sufficient pressure to ensure that the anti-tips are operating properly. *If you ignore this Warning, you may fall, tip over or lose control of the wheelchair and seriously injure yourself or others or damage the wheelchair.*

Figure 13-10
Mounting

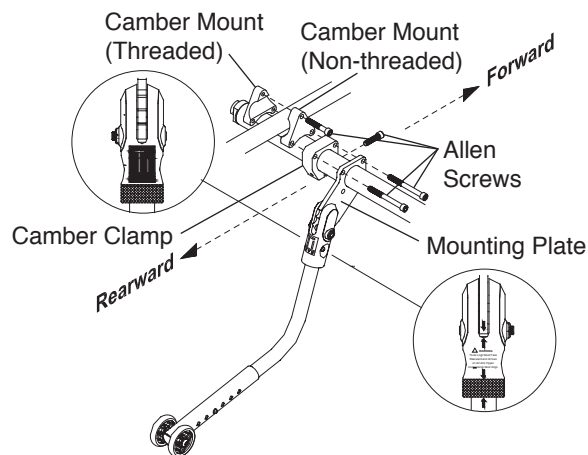

USER-FRIENDLY ANTI-TIPS

(TR Series 3)

Engaging

To engage the User-Friendly Anti-Tip, grip the anti-tip firmly, pressing down on the release lever, lower the anti-tip until the anti-tip receiver re-engages in the anti-tip mount in the “down” position shown in Figure 13-11.

Figure 13-11
Engaging

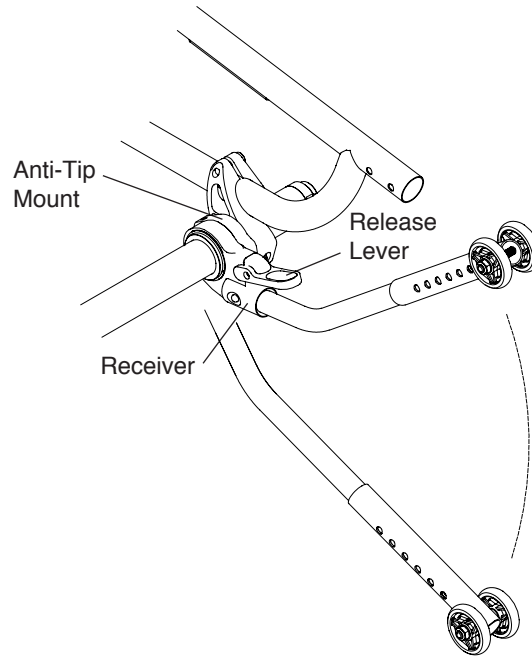

Disengaging

To disengage the User-Friendly Anti-Tip, grip the anti-tip firmly, pressing down on the release lever, raise the anti-tip until the anti-tip receiver re-engages in the anti-tip mount in the “up” position shown in Figure 13-12.

Figure 13-12
Disengaging

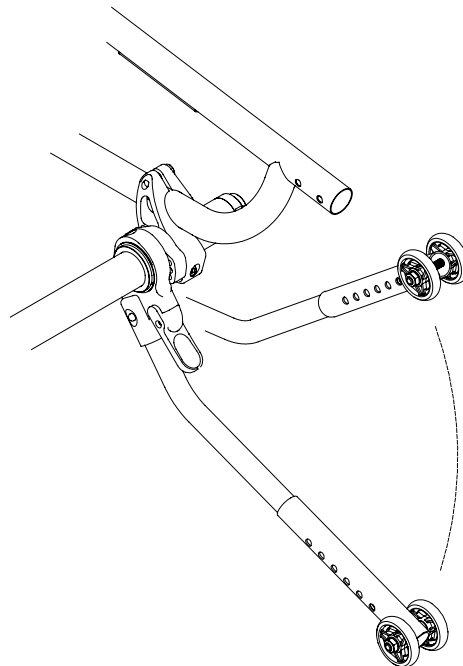

CHAPTER 13: ANTI-TIPS

Adjusting

To adjust the height of the User-Friendly Anti-Tip, press the two release buttons on the telescoping lower tube and adjust the height of the lower tube so that the wheel is within 1-1/2" to 2" off the ground. See Figure 13-13.

Figure 13-13
Adjusting

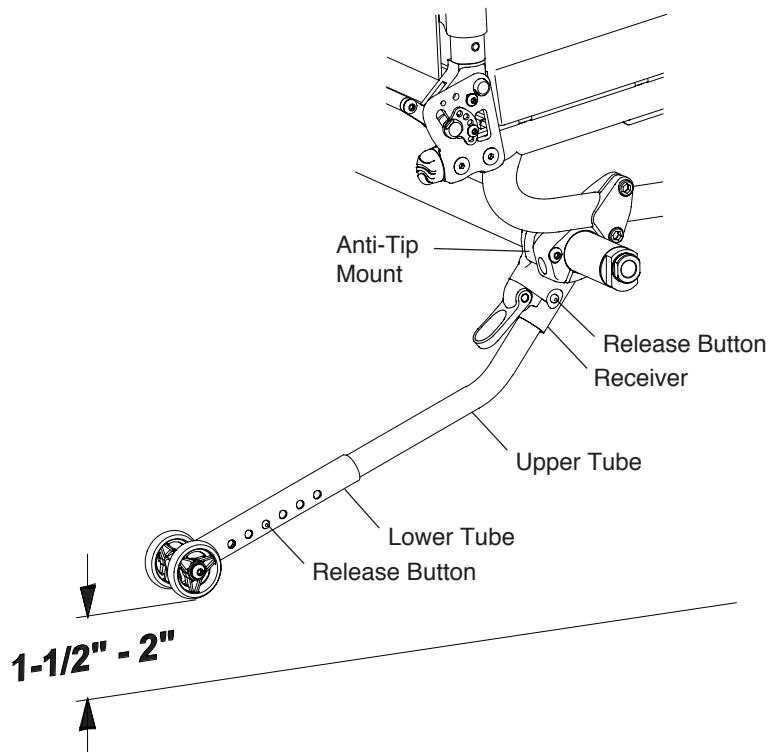

Removing

To remove the User-Friendly Anti-Tip tube, press the two release buttons on the anti-tip receiver and pull the upper tube out of the anti-tip receiver. See Figure 13-13.

Mounting

⚠ WARNING

Only an authorized TiLite dealer or qualified technician should install the anti-tip receiver. *If you ignore this Warning, you may fall, tip over or lose control of the wheelchair and seriously injure yourself or others or damage the wheelchair.*

⚠ WARNING

Do not disassemble the anti-tip mounting assembly. See Figure 13-14. *If you ignore this Warning, you may fall, tip over or lose control of the wheelchair and seriously injure yourself or others or damage the wheelchair.*

Tools Needed:

- 5/32" Allen Wrench
- 3/16" Allen Wrench

1. Remove the rear wheels and place the frame on a level surface.
2. Remove the camber tube. See "Replacing the Camber Tube (TR Series 3)" on pages 8-3 and 8-4.
3. Thread the Allen screw through the right side camber mount and into the right side anti-tip mount using the center of the three threaded holes and loosely tighten. See Figures 13-14.
4. Repeat Step 3 with the left side camber mount and the left side anti-tip mount.
5. Reinstall the camber tube. See "Replacing the Camber Tube (TR Series 3)" on pages 8-3 and 8-4.

6. With the wheelchair standing upright on a level surface, engage the anti-tip as described under “Engaging” on page 13-7.
7. Adjust both lower tubes so that the wheels are within 1-1/2” to 2” off the ground. See Figure 13-13. If this is not possible, proceed to Step 8. If you can achieve the proper ground clearance, proceed to Step 9.
8. If you cannot achieve the proper ground clearance in Step 7, then remove the Allen screw installed in Step 3 and reinstall it in either the upper or lower holes in the anti-tip mounts. Then repeat Steps 6 and 7.
9. Securely tighten the Allen screws that secure the camber mounts to the anti-tip mounts.
10. Securely tighten the Allen screw in each anti-tip mount to secure the anti-tip mount to the camber tube.
11. Check Toe-In/Toe-Out and adjust as needed.

△ WARNING

Both anti-tips **MUST** be mounted using the identical threaded hole in each of the anti-tip mounts. *If you ignore this Warning, you may fall, tip over or lose control of the wheelchair and seriously injure yourself or others or damage the wheelchair.*

△ WARNING

Before sitting in the chair, make sure that the anti-tips are operating properly. To do this, place the unoccupied chair on a level surface, engage the anti-tips, and tip the chair backward until the anti-tips are supporting the weight of the chair. Apply sufficient pressure to ensure that the anti-tips are operating properly. *If you ignore this Warning, you may fall, tip over or lose control of the wheelchair and seriously injure yourself or others or damage the wheelchair.*

Figure 13-14
Mounting

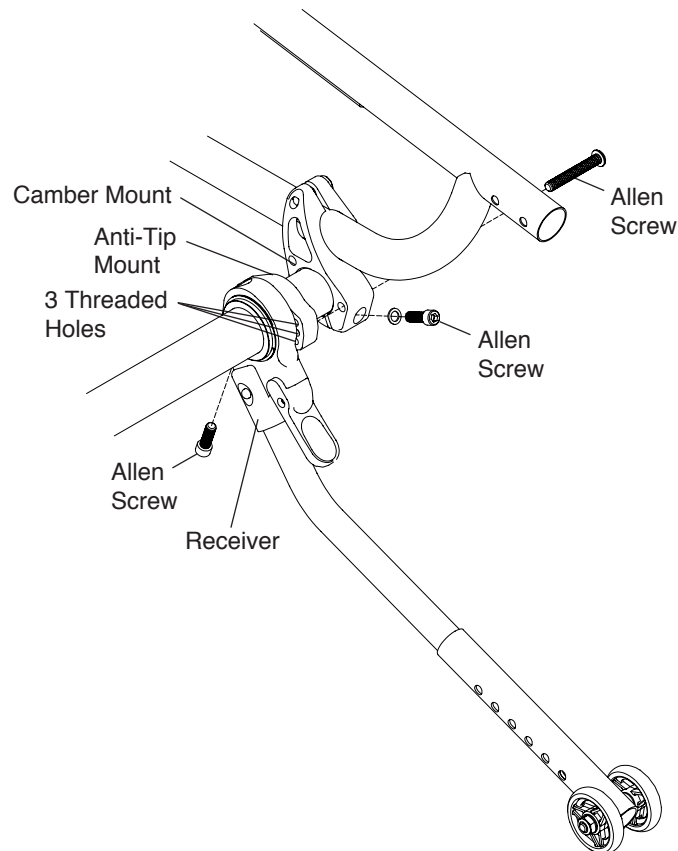

CHAPTER 13: ANTI-TIPS

Standard Titanium 5th Wheel with Single Swivel Caster

Adjusting

Tools Needed:

- 3/16" Allen Wrench

1. Loosen the Allen screw on each clamp. See Figure 13-15.
2. Adjust the anti-tip forward or backward. Make sure the 5th Wheel is centered relative to the frame.

Note: When adjusting the depth of the 5th Wheel, make sure at least 1-1/2" of the 5th Wheel tube remains inside the frame tube, measuring from the front of the frame.

3. Tighten the Allen screws.

Figure 13-15
Adjusting

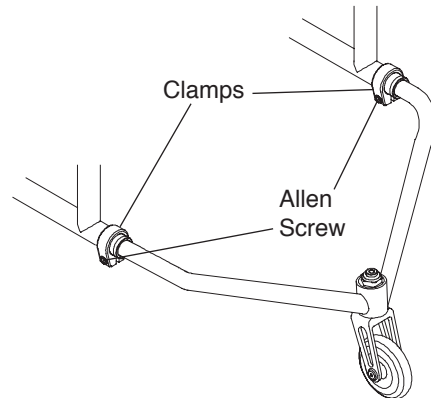

Quick-Release Titanium 5th Wheel with Single Swivel Caster

Adjusting

Tools Needed:

- 5/32" Allen Wrench

1. Lift up on the handles of the quick-release clamps and turn counter-clockwise while holding the nuts in place to permit the 5th Wheel tube to slide in or out of the frame. See Figure 13-16.
2. Loosen the Allen screws on the clamp stops on the 5th Wheel tube.
3. Adjust the anti-tip forward or backward to desired position.

Note: When adjusting the depth of the 5th Wheel, make sure at least 2" of the 5th Wheel tube remains inside the frame tube, measuring from the front of the clamps.

Figure 13-16
Adjusting

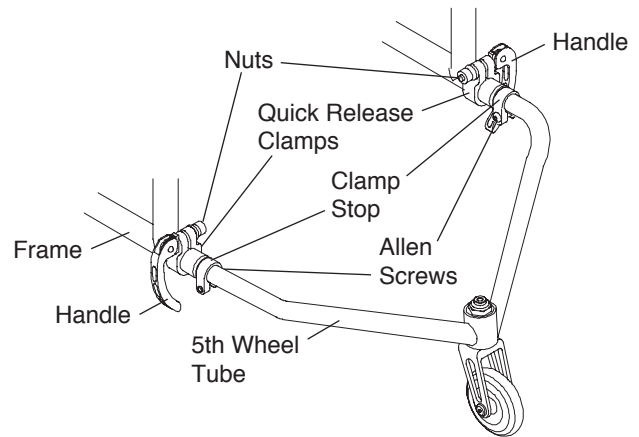

4. Rotate the handles of the quick-release clamps clockwise while holding the nut in place and engage the quick release clamps to secure the 5th Wheel tube inside the frame.
5. Slide the clamp stops along the 5th Wheel tube until they are flush with the frame sleeves and tighten the Allen screws.
6. The clamp stops serve to mark the position of the 5th Wheel so you can quickly remove the 5th Wheel by releasing the quick-release clamp and reinstall it later to the precise position.

5th Wheel Swivel Caster

Adjusting the Height

Tools Needed:

- 3/4" Open End Wrench

1. Remove the locknut. See Figure 13-17.
2. Remove the caster wheel assembly.
3. To lower the height of the 5th wheel, move the spacers from above the caster barrel to below it. To raise the height, reverse this procedure.

Note: Do not remove spacers from this assembly or a sloppy caster stem will result.

4. Replace the locknut on the caster stem and tighten to achieve desired swivel tension.

Figure 13-17
5th Wheel Caster Adjustment

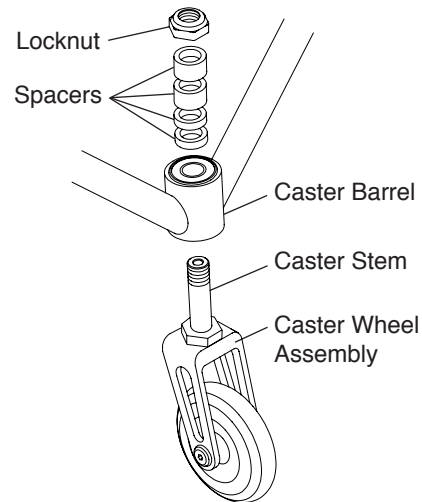

Front Roller

Removing

Tools Needed:

- 1/8" Allen Wrench

With an open loop footrest:

1. Remove the two Allen screws. See Figure 13-18.
2. Remove the Front Roller assembly.

⚠ WARNING

The threads on the Allen screws that connect the Front Roller to the footrest tube are treated with Loctite® 242®, a medium strength thread lock. If you loosen either Allen screw, you **MUST** remove and reapply Loctite® 242® or an equivalent medium strength thread lock. *If you ignore this Warning, your Front Roller could fall off and you could fall, tip over or lose control of the wheelchair and seriously injure yourself or others or damage the wheelchair.*

Figure 13-18
Front Roller

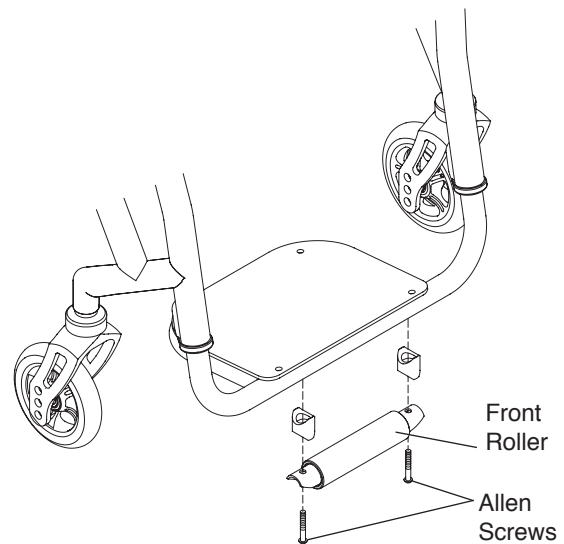

With an angle adjustable footrest:

1. Remove the Allen screws that secure the Front Roller to the roller plate. See Figures 13-19 and 13-20.
2. Remove the Allen screws that secure the footplate and the clamp to the roller plate.
3. Reassemble the angle adjustable footplate as shown in Figure 3-6.

Note: If removing the Front Roller from an angle adjustable footrest, you will need to order new, shorter Allen screws and washers to secure the footplate to the clamp.

CHAPTER 13: ANTI-TIPS

Figure 13-19
Front Roller with Angle Adjustable Footplate

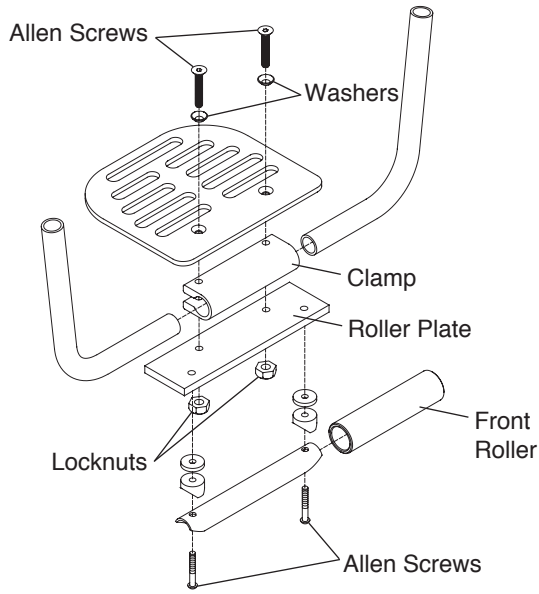
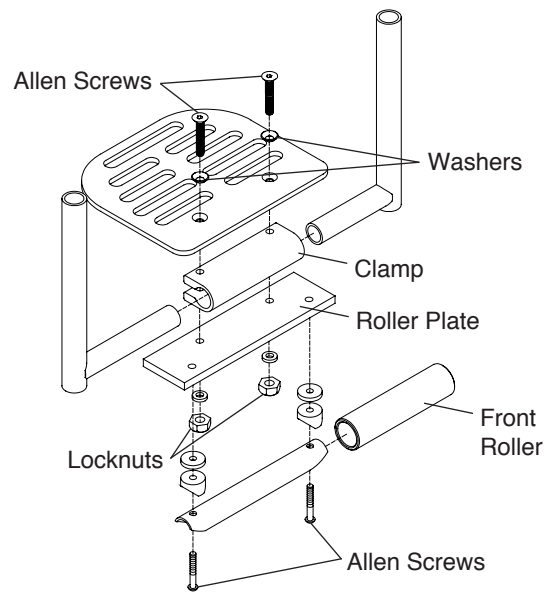

Figure 13-20
High Mount Front Roller with Angle Adjustable Footplate





tilite.com

P 800.545.2266 | 509.586.6117
F 866.586.2413 | 509.585.8703

2701 West Court Street, Pasco, WA 99301

A PRODUCT SUPPORTED BY:



usersfirst.org